

Components required:

1. 1x Work surface
2. 1x Rear aluminum rail long
3. 2x Side aluminum rail 24" or 30"
4. 1x Extended aluminum rail 36"
(Only "L" Surfaces)
5. 1x Front steel crossbar long
6. 2x Rear steel crossbar short
7. 2x Corner brace
8. 2x Foot
9. 1x Wire tray
10. 2x Plastic tray cover
11. 6x Screen mount (Optional)
12. 6x Screen bolt (Optional)
13. 2x Modesty/Privacy screen (Optional)
14. 1x Bag hook (Optional)
15. 1x Inset control switch
16. 2x Leg
17. 1x Control box
18. 2x Motor cable
19. 1x Power cord
20. 1x Aluminum rail hardware bag
21. 1x Base frame hardware bag
22. 1x Wire tray hardware bag
23. 1x Modesty/Privacy hardware bag
24. 1x Bag hook hardware bag

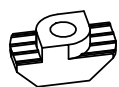

A x 23 (N10xm6)
RO11175



B x 39 (m6x12)
RO11074

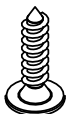

C x 36 (5x20mm)
RO11530

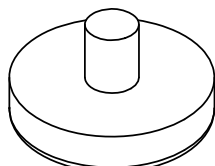

D x 4 (GLIDE)
RM-175

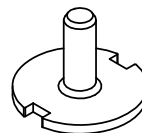

E x 6 (SCREEN BOLT)
RO13060

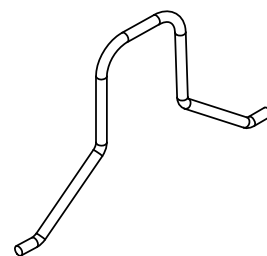

F x 1 (COIL CLIP)

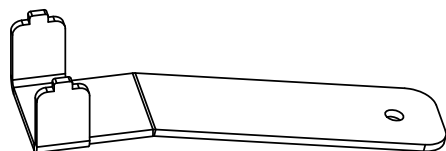

G x 1 (Screen tool)

Tools required: Drill driver, Phillips bit PH2, and Hex key 4mm

Human Active Technology
800 524 2744
customerservice@team-hat.com
team-hat.com

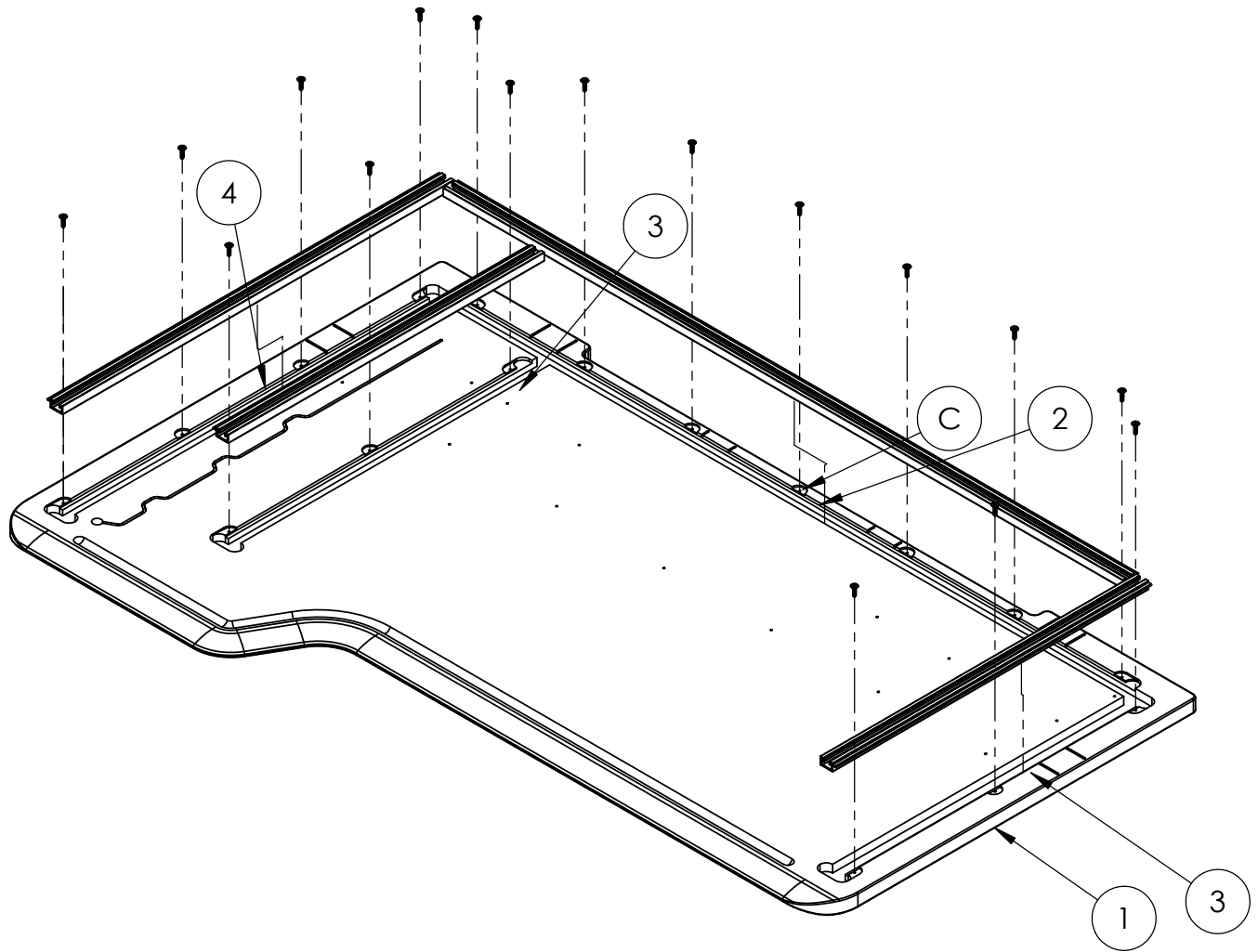

Step 1:

Insert rear aluminum rail(2) into rear slot in work surface(1). Press into place.

Insert side rails(3) into left and right-hand slots in work surface(1). Press into place.

Note: On "L" shaped work surfaces side rail(3) on handed end is shifter to a central position.

Insert extended rail(4) into extended slot in work surface(1). Press into place.

Note: Only "L" shape work surfaces will require an extended aluminum rail on the handed side of the work surface(1).

Using (17)x (5x20mm) wood screws(C) for an "L" style workstation, and (13)x (5x20mm) wood screws(C) for a rectilinear style workstation secure rear, side, and extended aluminum rails(2,3,4) into work surface(1) through provided pilot hole locations.

Tools required: Drill driver, Phillips bit PH2, and Hex key 4mm

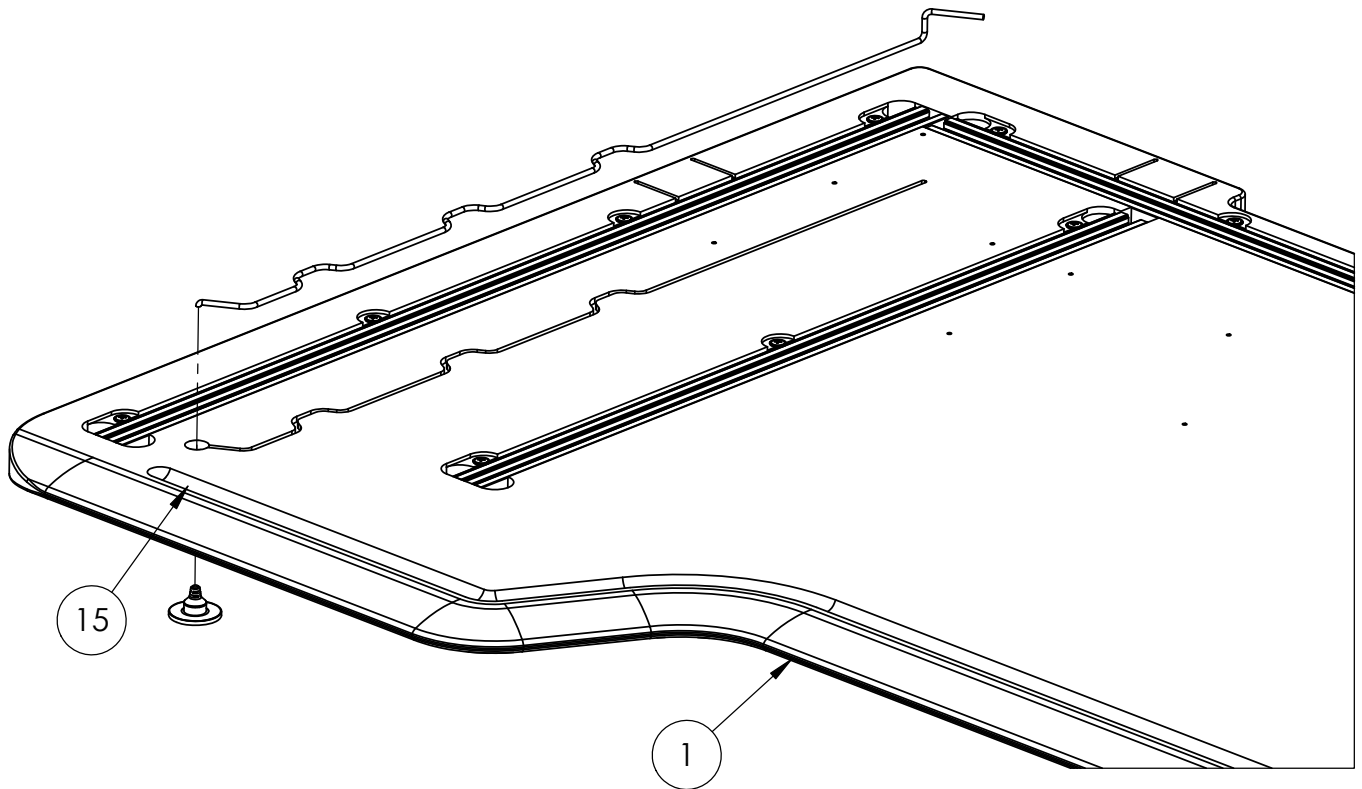

Step 2:

Feed inset control switch(15) cable through the hole cutout in the work surface(1).

Peel off the film on the back-side of the control switch and press into switch pocket in work surface (1).

Note: Please take note of switch orientation. The SIS logo should be right-side-up from the perspective of the user.

Press control switch cable(15) into channel on the bottom of the work surface(1) to secure the control switch and cable(15) in place.

Recheck the orientation of the control switch in the top surface of the work surface (1), and then apply firm pressure to secure.

Tools required: Drill driver, Phillips bit PH2, and Hex key 4mm

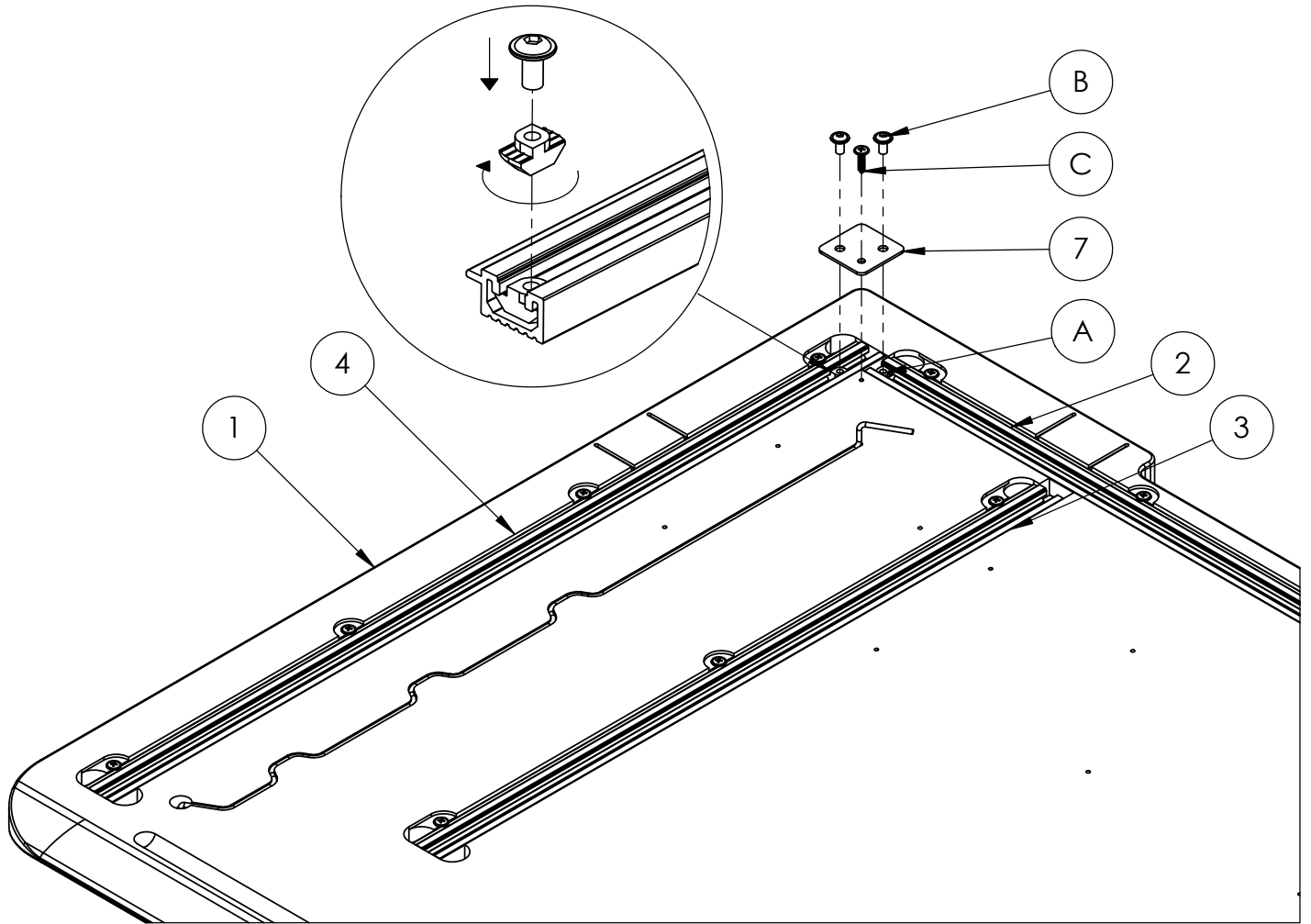

Step 3:

Attach a corner brace(7) to the intersection between the rear aluminum rail(2) and the outer rails(3) or (4), depending if its an "L" shaped or rectilinear work station.

Connect the corner brace(7) to the aluminum rails with (2)x (m6x12) machine screws(B) and (2)x (N10xm6) T-nut(A). Place the T-nuts(A) into the aluminum channels with the ribbed side facing up. Insert a machine screw(B) thru the corner brace(7) and slowly rotate to lock in place. Repeat on other side of table.

Attached (1)x (5x20mm) wood screw thru the corner brace(7) and into the provided pilot hole in the work surface(1).

Repeat this attachment for opposing rail intersection on the bottom-back-side of the work surface(1).

Tools required: Drill driver, Phillips bit PH2, and Hex key 4mm

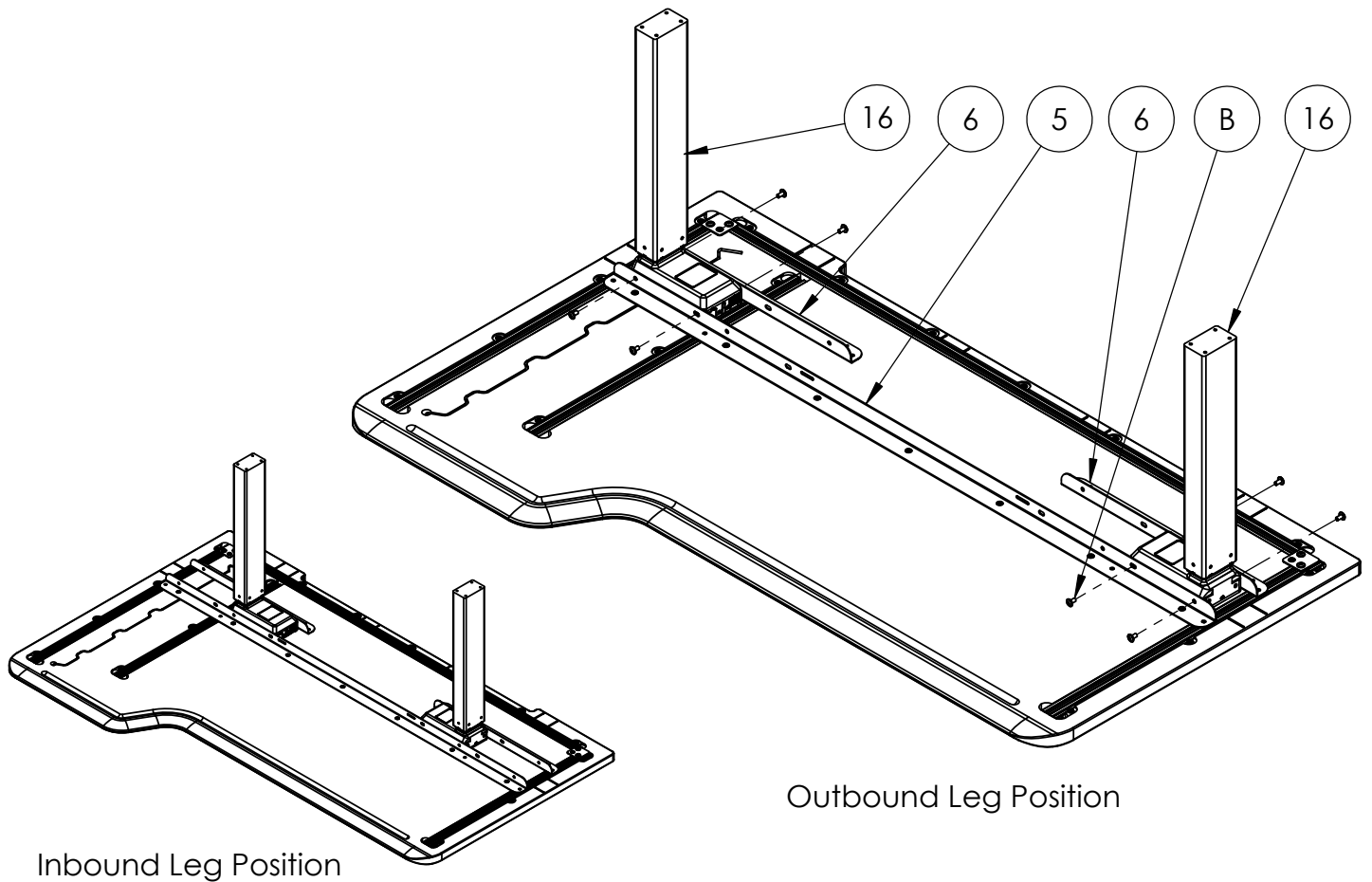

Step 4:

Attach (2)x table legs(16) to the (1)x front steel crossbar(5) and the (2)x rear steel crossbars(6) with (4)x (m6x12) machine screws(B) per table leg(16) as shown above.

The table legs(16) can be mounted in an inbound or outbound position depending on desired use and space needs on site. The above assembly reflects an outbound mounting position.

To mount the table legs(16) in an inbound position, shift the legs(16) inward by 8.5" in either direction and mount through the next set of provided mount holes in the front steel crossbar(5) and the (2)x rear steel crossbars(6).

Note: Either of the table legs can be set in an inbound and outbound position to accommodate special needs, while maintaining structural stability.

Tools required: Drill driver, Phillips bit PH2, and Hex key 4mm

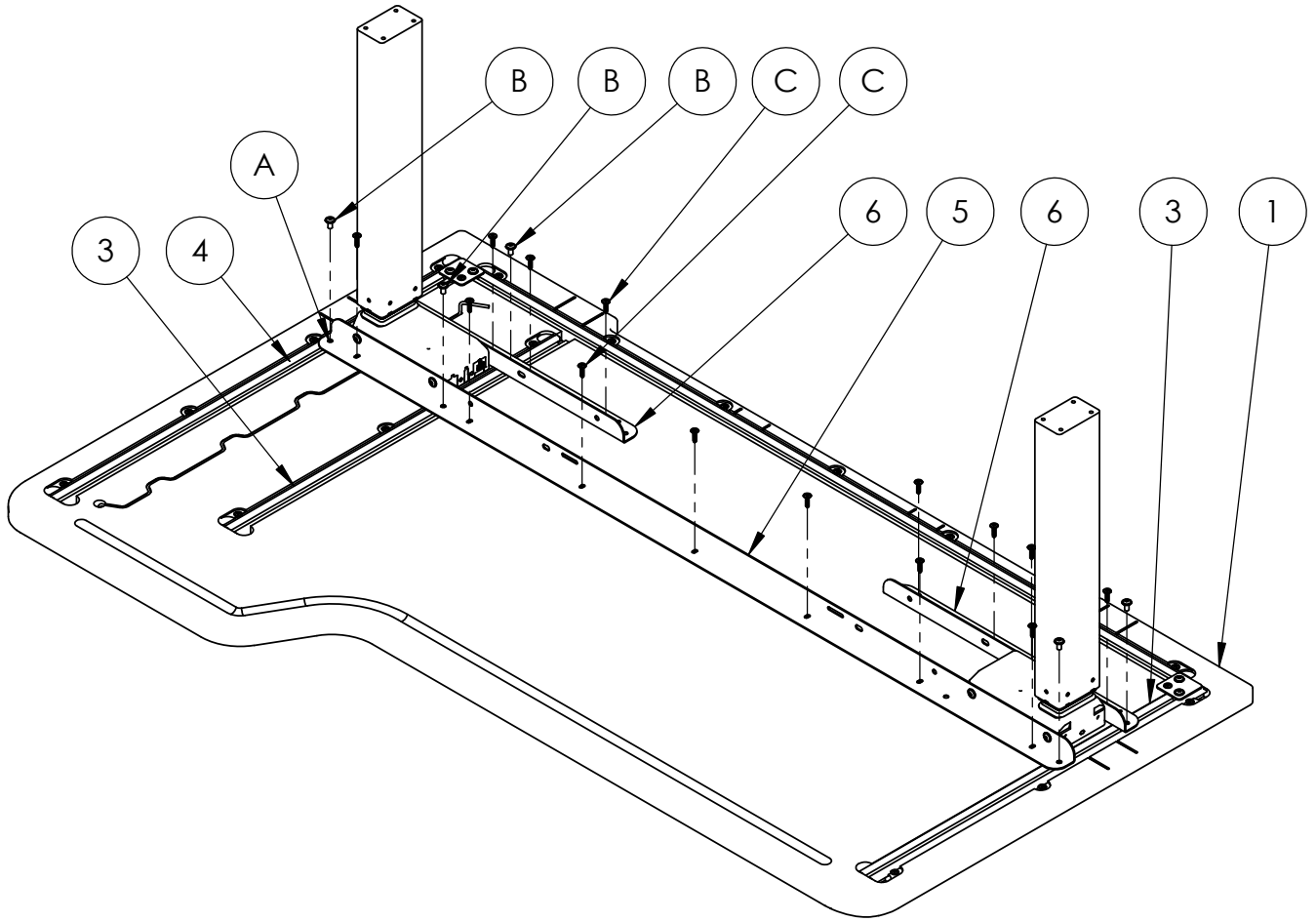

Step 5:

Attach the front steel crossbar(5) to the work surface(1) with (7)x (5x20mm) wood screws(C), and then attach the (2)x rear steel crossbars(6) to the work surface(1) with (4)x (5x20mm) wood screws(C) per crossbar(6).

Attach the ends of the front steel crossbar(5) and the ends of the rear steel crossbars(6) to the outer aluminum rails(3,4) with (4)x (m6x12) machine screws(B) and (4)x (N10xm6) T-nuts(A).

Note: For "L" shaped work surfaces(1), also attach front steel crossbar(5) and rear steel crossbar(6) to side aluminum rail(3) on handed side of work station(1) with (1)x (m6x12) machine screw(B) and (1)x (N10xm6) T-nut(A) per crossbar.

Tools required: Drill driver, Phillips bit PH2, and Hex key 4mm

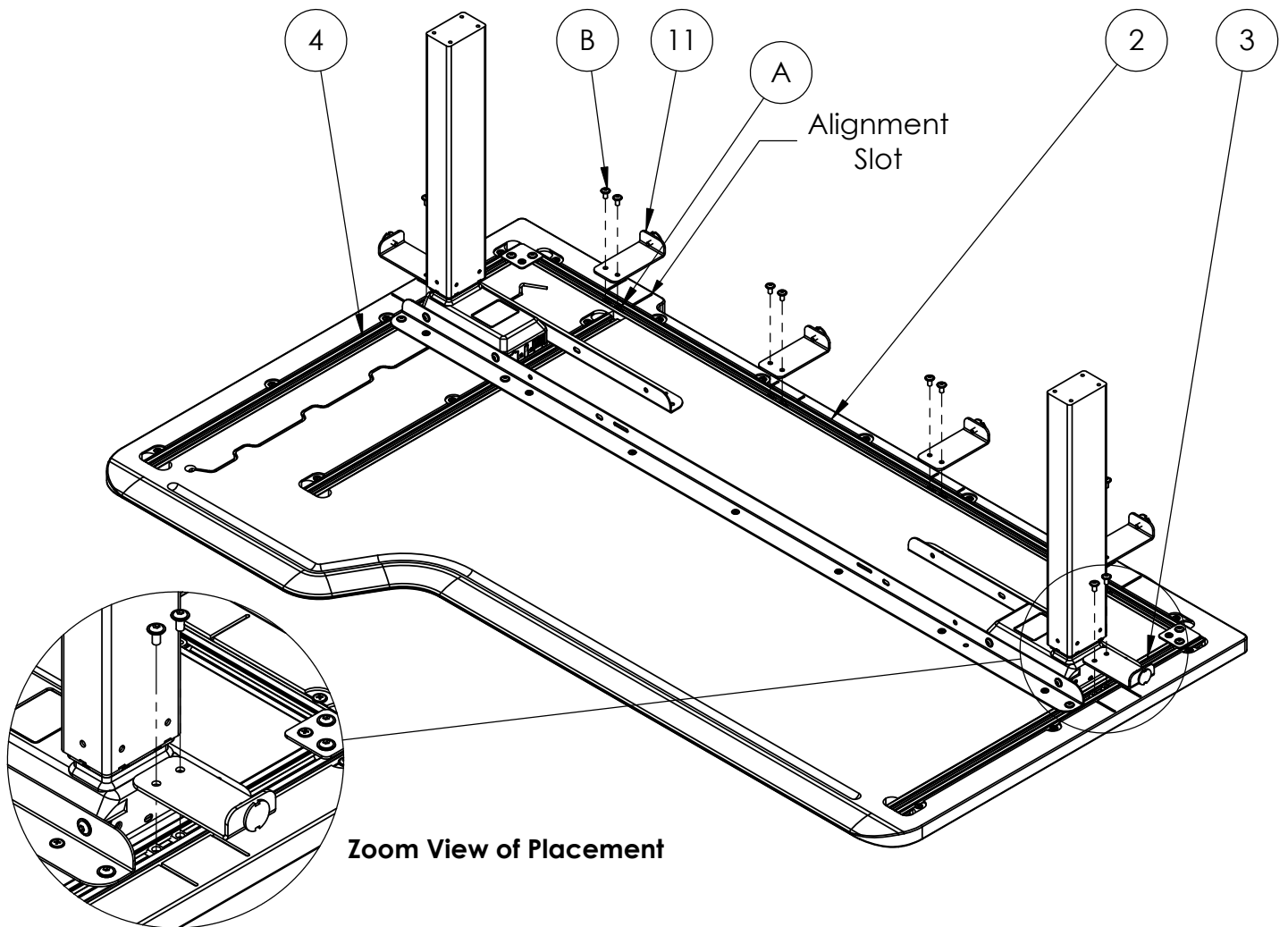

Step 6:

Optional modesty/privacy attachment. If table was not purchased with modesty/privacy screens, than proceed to step 7.

Attached each screen mount(11) to the aluminum rails with (2)x (m6x12) machine screw and (2)x (N10xm6) T-nut(A) in the marked locations. The work surface(1) will be marked with alignment slots to indicate the screen mount(11) mounting position. Center the mount between the alignment slots and secure.

Work stations can be purchased with a single screen, or as a set. Each modesty/privacy screen(13) requires (3)x screen mounts(10); one on the side of the table and two along the back edge.

Tools required: Drill driver, Phillips bit PH2, and Hex key 4mm

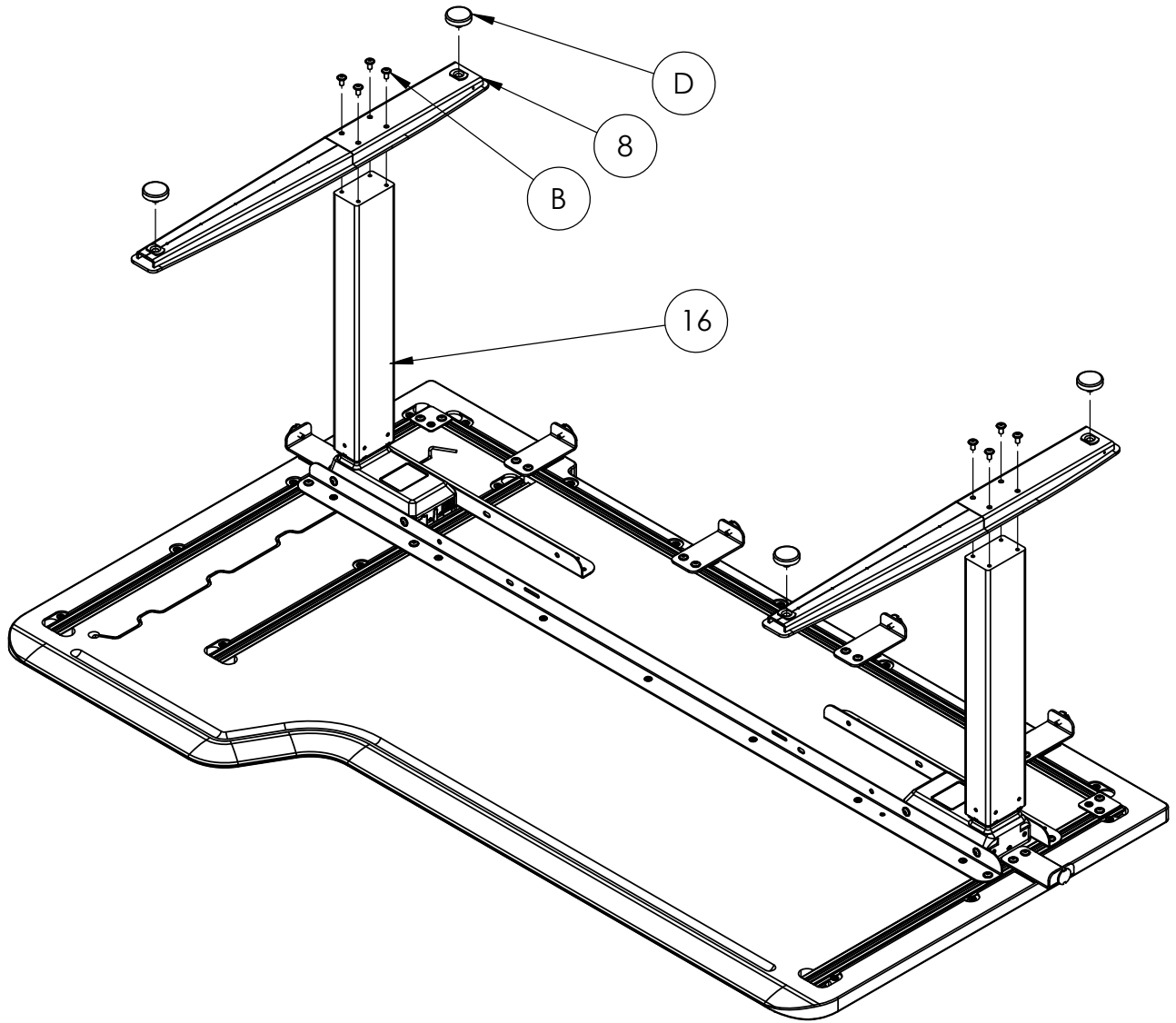

Step 7:

Attach the feet(8) to the legs(16) with (4)x (m6x12) machine screws(B) per foot(8).

Attach (2)x glides(D) to each foot(8).

Tools required: Drill driver, Phillips bit PH2, and Hex key 4mm

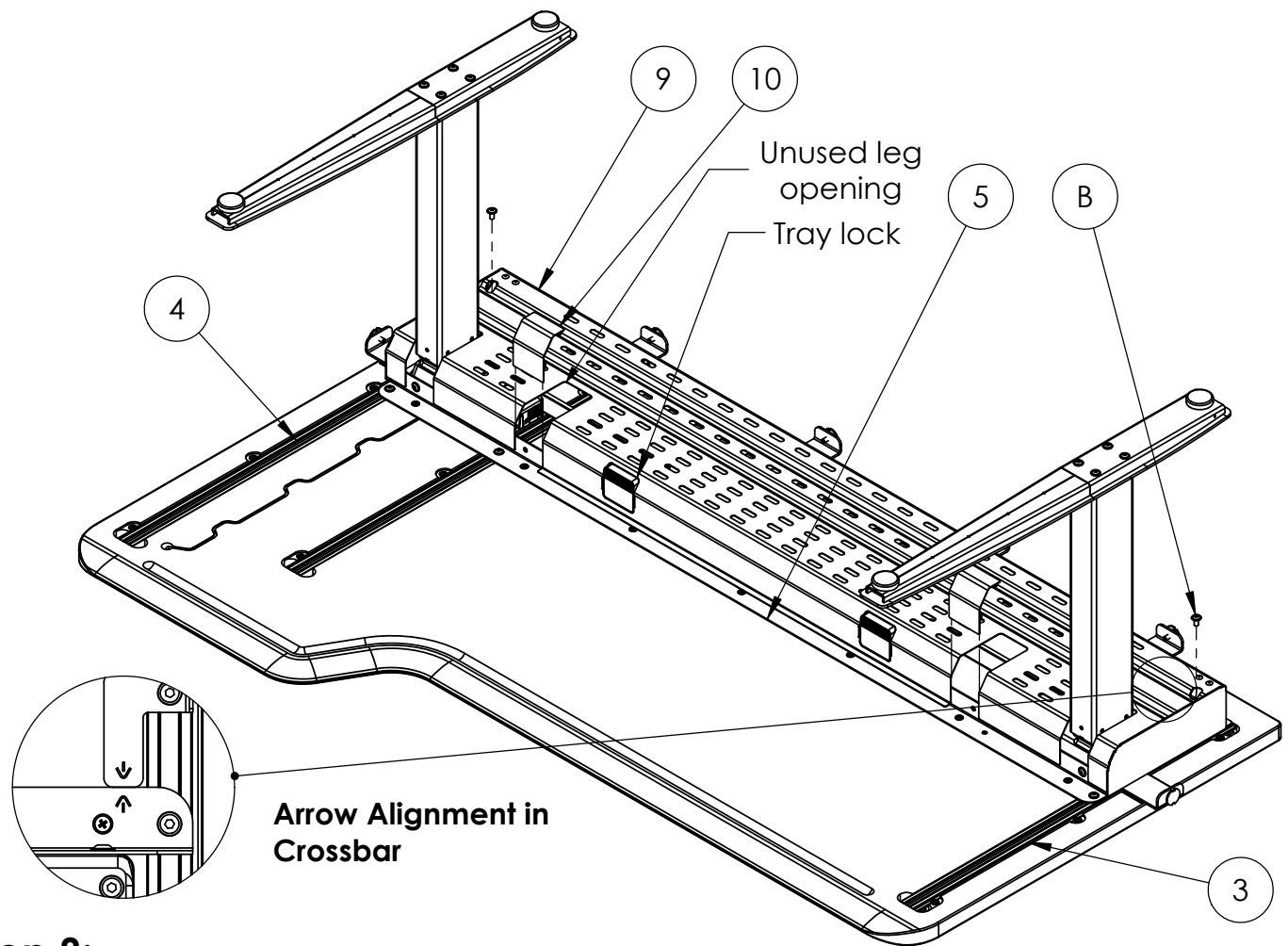

Step 8:

Place the wire tray(9) on the work surface(1) as shown above.

Push the wire tray(9) mount brackets up against the rear steel crossbars(6). The wire tray mount brackets are marked with arrows indicating the edge that should be flush with the back of the rear steel crossbars(6).

Attach wire tray(9) to right and left outer aluminum rails (3,4) with (1)x (m6x12) machine screw(B) and (1)x (N10xm6) T-nut(A) per rail. Secure in place.

Ensure that that both tray locks engage with the slots in the front steel crossbar(5). If the locks do not engage, loosen the mount bolts(B), re-engage the tray locks, and secure in place.

Attach the plastic tray covers(10) to the wire tray(9) in the unused leg openings in the wire tray(9).

Tools required: Drill driver, Phillips bit PH2, and Hex key 4mm

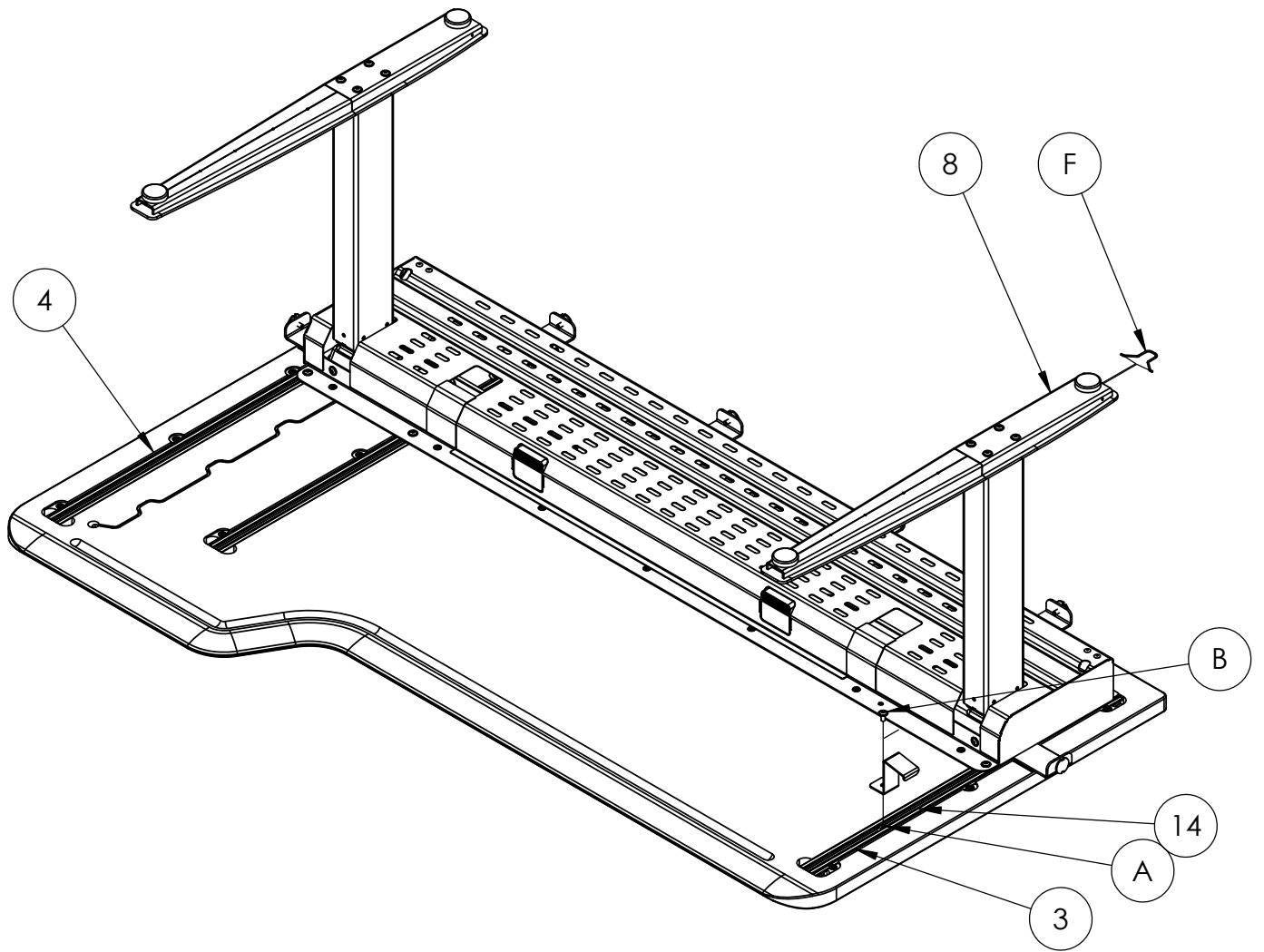

Step 9:

Determine which direction the power cord will run once the work station is fully assembled. Attach the Coil clip(F) to the back-side of the foot(8) that is in the path to which the power cord will run. Squeeze the coil clip(F), insert into the back-side of the foot(8), and lock into provided mount holes.

Attach the bag hook(14) to one of the outer aluminum rails(3 or 4) with (1)x (m6x12) machine screw(B) and (1)x (N10xm6) T-nut(A).

Note: The bag hook(14) can be attached on either the right or left side of the work station in any free section of aluminum rail per the users requirements.

Tools required: Drill driver, Phillips bit PH2, and Hex key 4mm

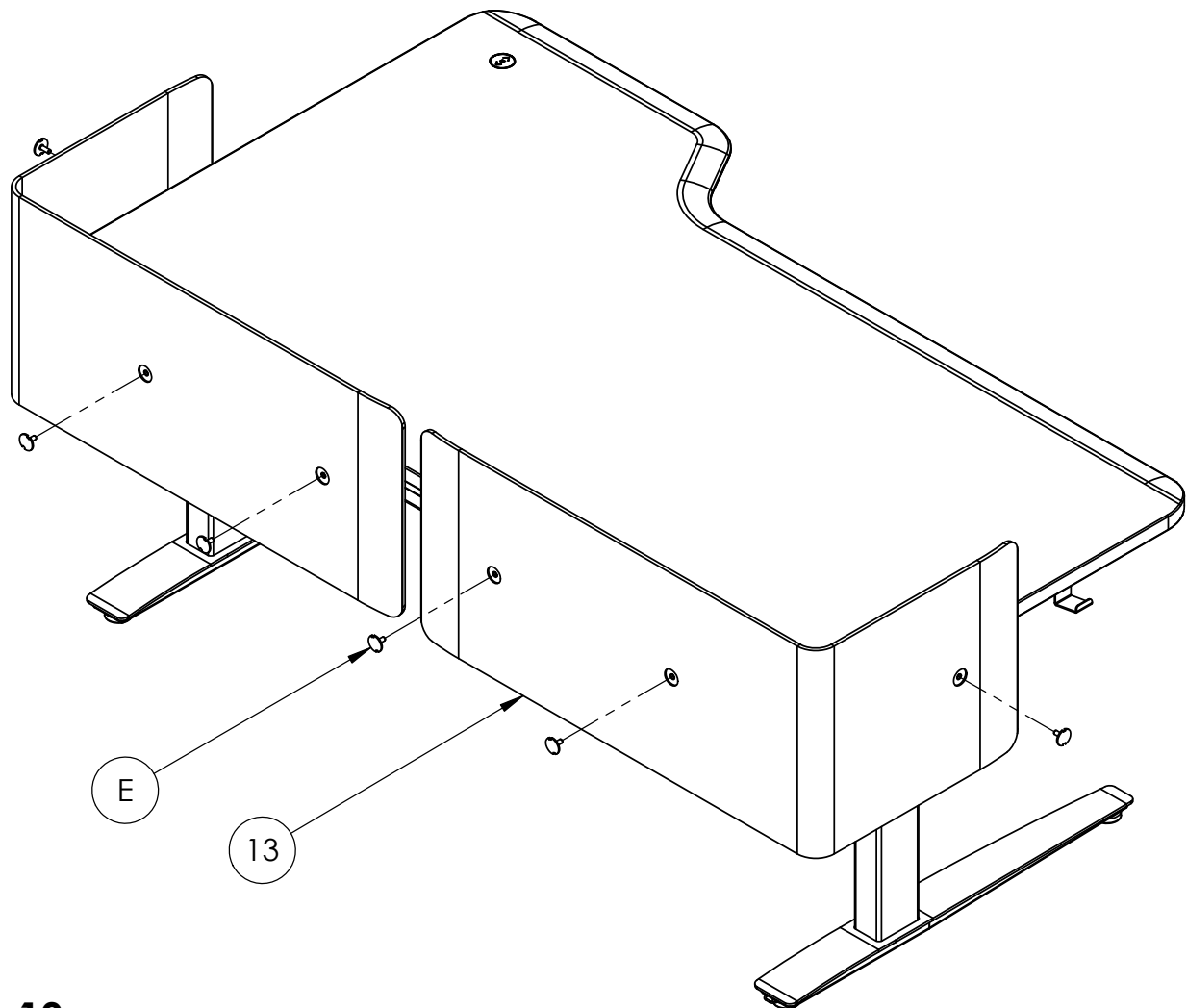

Step 10:

Carefully rotate the work station onto its feet; ensuring not to damage the screen mounts(11), coil clip(F), powder coat work surface(1), or any other table component.

Optional modesty/privacy screen(13) attachment. If table was not purchased with modesty/privacy screens(13), proceed to step 11.

Manually attach the modesty/privacy screen(13)to the screen mounts(11) with (1)x screen bolt(E) per mount. Tighten by hand.

Utilizing the screen attachment tool(G), fully secure each screen bolt(E) to its corresponding mount. Manually tighten by hand, and then fully secure with screen tool (G). Ensure not to scratch or damages wood screens.

Tools required: Drill driver, Phillips bit PH2, and Hex key 4mm

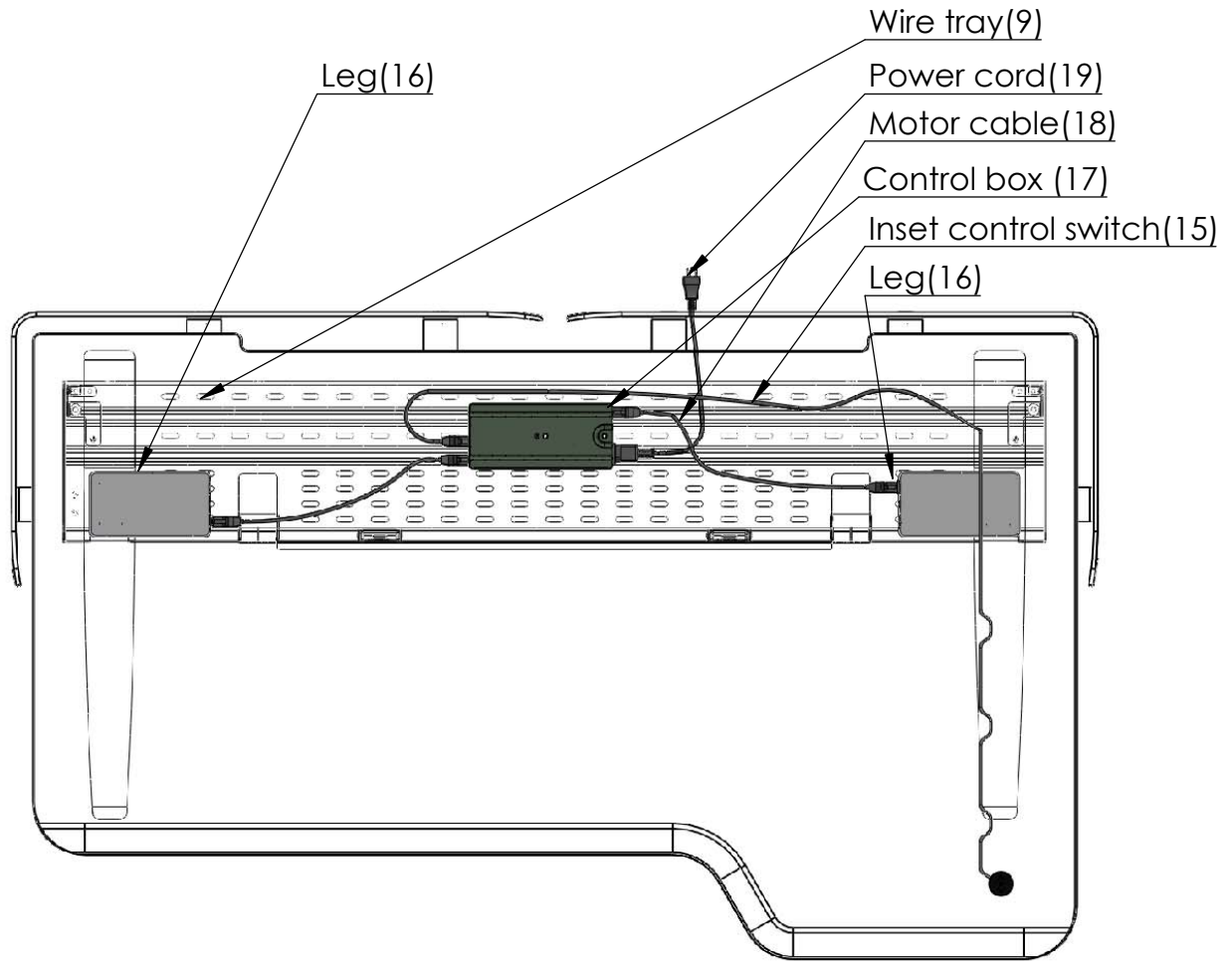

Secure control box(17) to wire tray(9) with two velcro bands found in the wire tray hardware bag(22).

Connect a motor cable(18) to the control box(17) and then to each leg(16).

Connect control switch cable(15) and power cord(19) to control box(17), and then connect power cord(19) to 120V power outlet.

Perform initial reset by pushing the down button until the table stops. Push the down-button again and "hold" until the legs stop moving.

Troubleshooting: Make sure that all cables are correctly connected to the control box, legs, control switch, and power source. Perform a new reset and make sure the procedure has completely finished before normal operation.

Tools required: Drill driver, Phillips bit PH2, and Hex key 4mm