

9110-HD-8460

Installation Instructions

NOTE: THERE MAY BE ADDITIONAL PARTS UNDER TRAY. PLEASE REVIEW ENTIRE PACKAGE PRIOR TO DISCARDING.

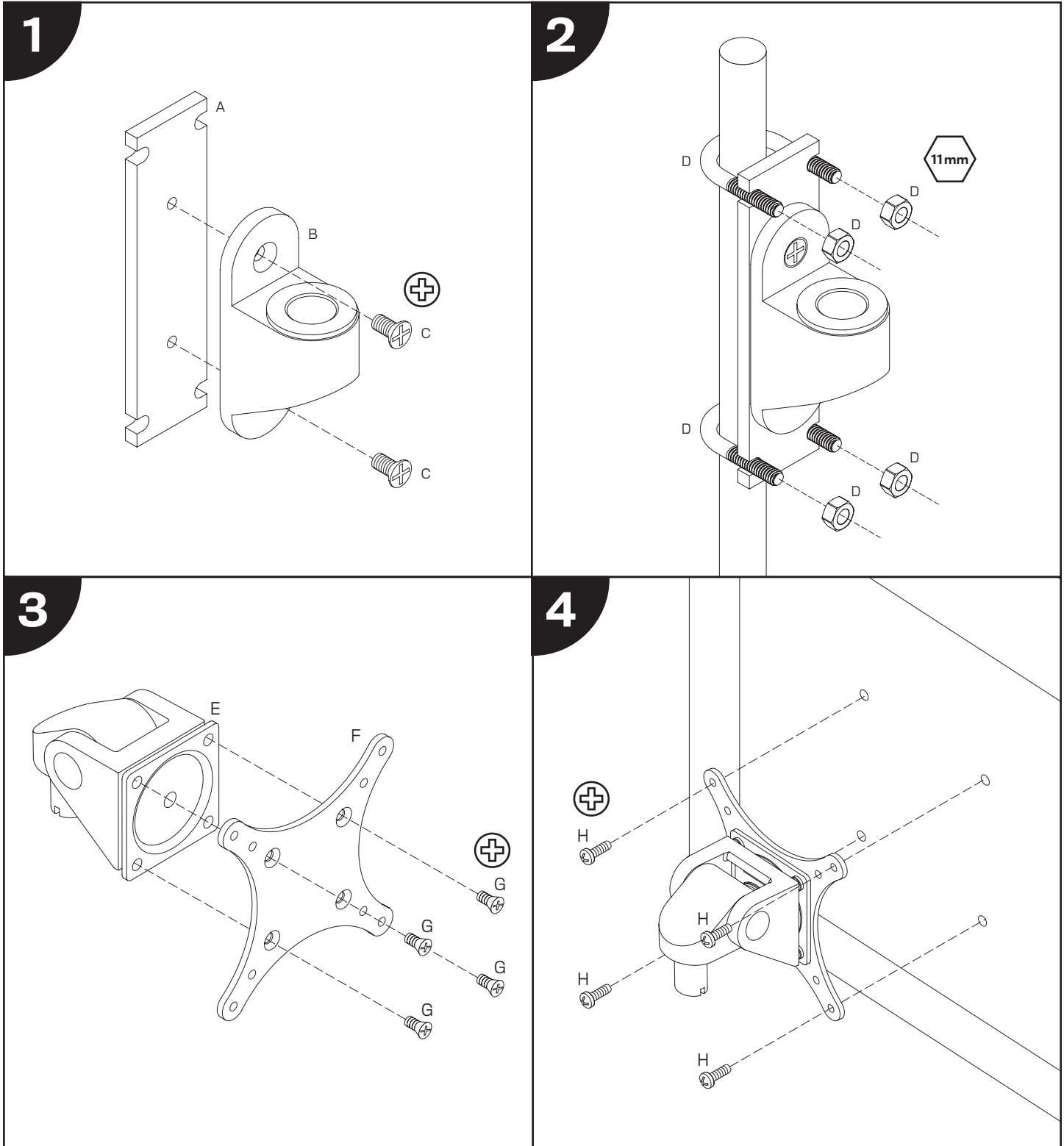

5



ATTENTION
Ensure weight ratio is correct when installing monitor to avoid shelf tipping.

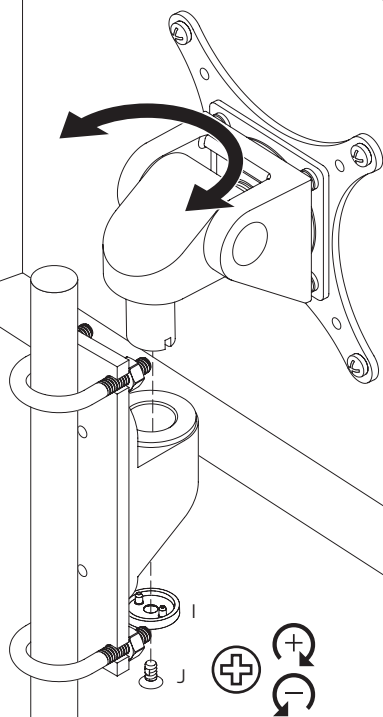

OR

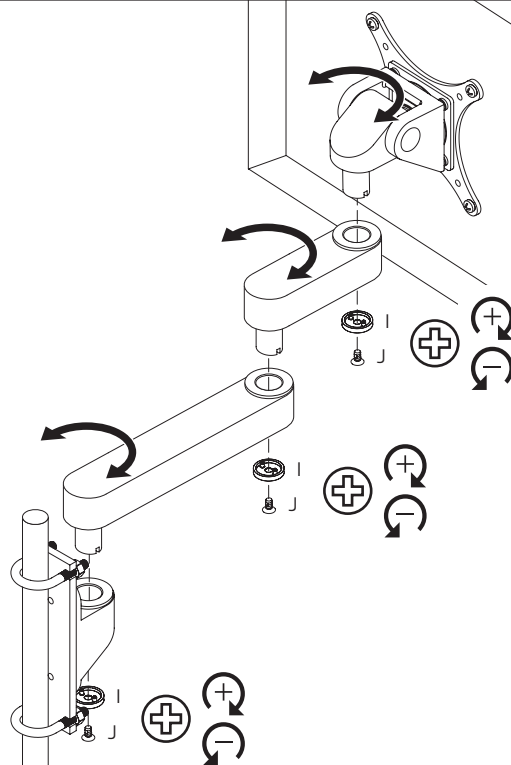

6

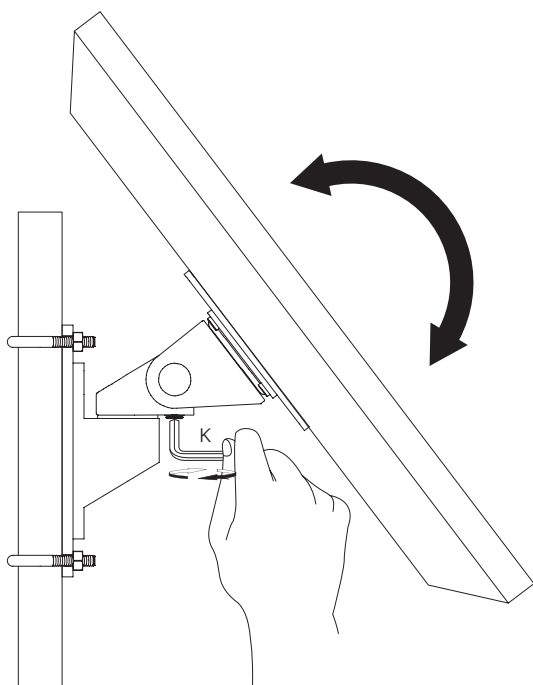





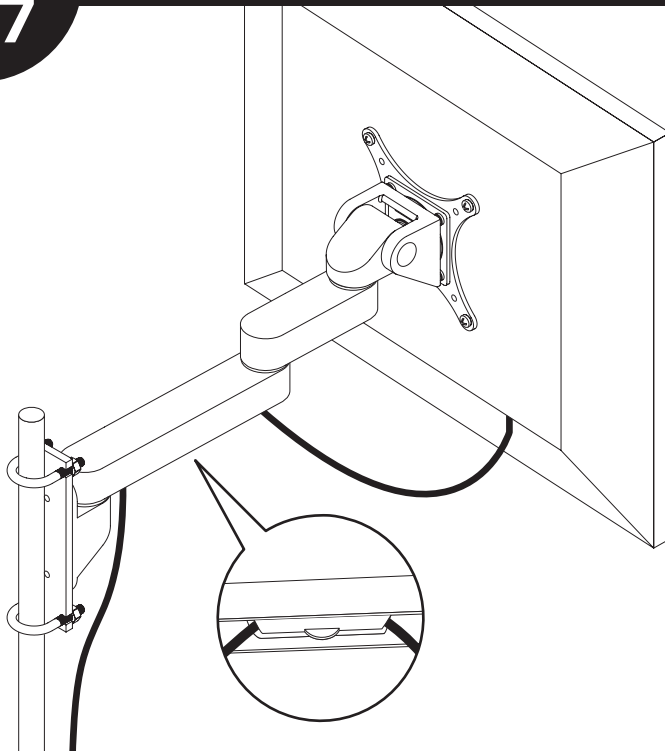

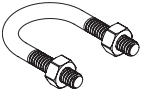
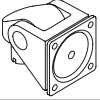

7

9110-8460-8.5, 9110-8460-8.5-4, 9110-8460-8.5-8.5 ONLY

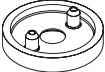

PARTS LIST

ITEM	DESCRIPTION / PART NO.	QUANTITY		
		9110-8460	9110-8460-4, 9110-8460-8.5	9110-8460-8.5-4, 9110-8460-8.5-8.5
A	 9110 Adapter Plate 111017	1	1	1
B	 Wall Mount RP406795	1	1	1
C	 FPhMS, 1/4-20 x 1/2 700987	1	1	1
D	 1/4-20 U-Bolt 111018	2	2	2
E	 Monitor Tilter 405397	1	1	1
F	 75/100mm VESA® Adapter Plate 105587	1	1	1
G	 10-32 x 3/8" Phillips Flat Head Screw 702281	1 (4-pack)	1 (4-pack)	1 (4-pack)
H	 M4-12 Phillips Pan Head Screw 702096	1 (4-pack)	1 (4-pack)	1 (4-pack)
I	 Dog Washer 105189	1	2	3
J	 10-32 x 3/8" FPhMS w/Lock Patch 705198	1	2	3
K	 7/32" Allen Wrench 701127	1	1	1