



HAT
COLLECTIVE™
HUMAN ACTIVE TECHNOLOGY

WORK YOUR WAY.

At HAT Collective, we're empowering individualization in the workplace. We believe the power to choose improves satisfaction, health, and productivity. Our products showcase craftsmanship and design innovation, enabling you to create your ideal workspace. Whether in the office or at home, sitting or standing, together or at a distance, our sophisticated range of workplace solutions lets you work your way.

TABLE OF CONTENTS

WORKSTATIONS	6
DIVIDERS	60
MONITOR ARMS	72
STORAGE	100
SEATING	108
ACCESSORIES	
Wire Management	116
Lighting	119
Power	120
Keyboard Trays	122
CPU Holders	123
Mounts & Adapters	123



WHY CHOOSE HAT COLLECTIVE?

We are a curious company, on a quest to empower individualization in the workplace through our collection of flexible, ergonomic solutions for the contract office market. Our brand is committed to quality and affordability, with an emphasis on customer service and exceptional levels of support for our network of dealers. It's easy to do business with HAT Collective.

EXCEPTIONAL SERVICE

Our reliable, responsive teams are dedicated to personalized service. Whether online or in person, we keep things simple. HAT Collective is easy to work with.

DESIGN-FORWARD

The efforts of our innovative in-house Danish and American manufacturing teams combine to create an aesthetically impactful product collection.

CUSTOM MADE EASY

Our products prioritize personalization, giving you a multitude of ways to create your ideal workspace.

QUICK SHIPPING

Bi-coastal warehouses and a large number of in-stock products mean we're able to fulfill orders in as little as three business days (or less).

WELL-PRICED

We remain committed to excellence and affordability as we endeavor to revolutionize well-being and productivity in the workplace.



WORKSTATIONS

HAT Collective workstations epitomize innovative design and functionality, helping to easily create an active, productive office environment. Sleek aesthetic and quality construction come together to provide a beautiful, healthy, and personalized work experience. Our standard product line offers unmistakable European flare and our in-stock bases are ideal for quick installations.

Problem solving for a complex environment or specific requests? Our Enhanced Design Solutions program enables total customization through professional design support and direct access to our manufacturing team.

To complete your personalized work environment, add power, modesty panels, storage, and more to create a comprehensive HAT Collective workspace.





IN-STOCK

MID HAT, 2-STAGE



This two-legged, height-adjustable base is the ultimate in workspace transformation. The exclusive Folding HAT frame design allows for easy assembly, quickly fitting into any corner or rectangular station. The quiet electric motor system is eco-friendly and makes movement simple.

HAT bases are reliably stocked in three colors, with optional custom color match capabilities. This clever design is expandable, with no fixed-width cross bar to stand in your way.

FEATURES

- **Handset:** With two mounting options, the Mid HAT's handset matches the design of the Reya Power Family for one continuous aesthetic.
- **Integrated:** Includes programmable three-position LED handset and cable manager.
- **Electric Lift:** Dual sync motors allow for a 250 lb. lift capacity, which raises at 1.2" per second.
- **Smart:** Anti-collision safety sensor prevents accidents.
- **Certified:** BIFMA, UL 962, GreenGuard, and qualifies for LEED credits.
- **A Safe Space™ Product:** Easily reconfigured to allow for social distancing in the workplace.

SPECIFICATIONS

Finishes

In-Stock:

White
WH

Silver
SI

Black
BK

Standard:

Steel Antique
DM

Steel Matte
HC

Dimensions

Height Range: 27.25" - 46.75"

Width Options: S: 24" - 41"
L: 42" - 72"

Worksurfaces

See page 47 for available worksurfaces

Part Numbers

HAT2-MID-S-__ (T-Foot)

HAT2-MID-L-__ (T-Foot)

HAT2-MID-S-C24-__ (C-Foot, 24")*

HAT2-MID-L-C24-__ (C-Foot, 24")*

HAT2-MID-S-C27-__ (C-Foot, 27")*

HAT2-MID-L-C27-__ (C-Foot, 27")*

WARRANTY

Motor & Parts: 12 Years

Craftsmanship: Lifetime

● In-stock product ships within 3 business days.
* C-Foot models are not an In-stock item, standard lead times apply.
30" deep worksurfaces require the T-Foot or 27" C-Foot.



IN-STOCK

HI HAT, 3-STAGE



Create an active work environment with a base that offers maximum height capability. With Hi HAT, users have increased access to movement, which allows for a healthier, happier, and more productive work life. This sturdy three-stage electric base uses an easy-to-assemble, folding frame design. The width of the base is expandable and includes a reliable, programmable handset, dual sync motors, and the assurance of an anti-collision safety monitor.

FEATURES

- **Handset:** With two mounting options, the Hi HAT's handset matches the design of the Reya Power Family for one continuous aesthetic.
- **Integrated:** Includes programmable three-position LED handset and cable manager.
- **Electric Lift:** Dual sync motors allow for a 250 lb. lift capacity, which raises at 1.5" per second.
- **Smart:** Anti-collision safety sensor prevents accidents.
- **Flexible:** Hi HAT also works in corner and 120-degree configurations.
- **Certified:** BIFMA, UL 962, GreenGuard, and qualifies for LEED credits.
- **A Safe Space™ Product:** Easily reconfigured to allow for social distancing in the workplace.

SPECIFICATIONS

Finishes

In-Stock:

White
WH

Silver
SI

Black
BK

Standard:

Steel Antique
DM

Steel Matte
HC

Dimensions

Height Range: 23.75" - 49"

Width Options: S: 24" - 41"
L: 42" - 72"

Worksurfaces

See page 47 for available worksurfaces

Part Numbers

HAT2-Hi-S-__ (T-Foot)

HAT2-Hi-L-__ (T-Foot)

HAT2-Hi-S-C24-__ (C-Foot, 24")*

HAT2-Hi-L-C24-__ (C-Foot, 24")*

HAT2-Hi-S-C27-__ (C-Foot, 27")*

HAT2-Hi-L-C27-__ (C-Foot, 27")*

WARRANTY

Motor & Parts: 12 Years

Craftsmanship: Lifetime

● In-stock product ships within 3 business days.
* C-Foot models are not an In-stock item, standard lead times apply.
30" deep worksurfaces require the T-Foot or 27" C-Foot.



IN-STOCK

HAT L UNIT, 3-LEG



This three-legged unit brings height adjustability to the furthest corners of your office. Whether you need a 90-degree or 120-degree angle, the L-Unit makes movement possible.

Sophisticated electric adjustments can be made with the press of a button on this three-stage base. The reliable sit-stand frame provides the flexibility needed for a healthy, productive day at work.

FEATURES

- **Handset:** With two mounting options, the HAT L Unit's handset matches the design of the Reya Power Family for one continuous aesthetic.
- **Integrated:** Includes programmable three-position LED handset and cable manager.
- **Electric Lift:** Tri-sync motors allow for a 350 lb. lift capacity, which raises at 1.5" per second.
- **Smart:** Anti-collision safety sensor prevents accidents.
- **Certified:** BIFMA, UL 962, GreenGuard, and qualifies for LEED credits.
- **A Safe Space™ Product:** Easily reconfigured to allow for social distancing in the workplace.

SPECIFICATIONS

Finishes

In-Stock:

White
WH

Silver
SI

Black
BK

Dimensions

Height Range: 23.75" - 49"

Width Options: 42" - 74"

Worksurfaces

See page 47 for available worksurfaces

Part Numbers

HAT3-HI-L- _ _

WARRANTY

Motor & Parts: 12 Years

Craftsmanship: Lifetime



HAT BENCHING



Shown with optional Cable Management Tray

This dynamic benching unit provides flexibility and affordability in one sleek solution. Replace traditional workstations with all-in-one benching, allowing employees to maintain movement by alternating between sitting and standing positions throughout the day. HAT benching quickly creates a productive, comfortable, and healthy office environment.

The HAT Benching design is available in various widths and can be used with PET, fabric, acrylic, or white board dividers. The unit incorporates a convenient built-in power and data beam, along with position programming and dual sync motors for safe, easy height adjustments.

FEATURES

- **Integrated:** A Power Beam, Power Trac with jumper connector, and programmable four-position LED hand set are incorporated.
- **Smart:** Anti-collision safety sensor prevents accidents.
- **Electric Lift:** Dual sync motors have a 300 lb. lift capacity.
- **A Safe Space™ Product:** Add in dividers to enable social distancing in the workplace.
- **Power:** All state electrical regulations can be met.



SPECIFICATIONS

Finishes

In-Stock:

White
WH

Silver
SI

Black
BK

Dimensions

Height Range: 27.25" - 46.75"

Width Options: 48", 60", 72"

Worksurfaces

See page 47 for available worksurfaces

Part Numbers

DBUHAT-48-MID-L-__

DBUHAT-60-MID-L-__

DBUHAT-72-MID-L-__

WARRANTY

Motor & Parts: 12 Years

Craftsmanship: Lifetime



HAT GROUP & CONFERENCE TABLE



Team meetings may be long, but they don't have to be painful. This four-legged electric conference base means even shared workspaces can transition from sit to stand.

Improve the productivity of your brainstorming sessions with this impressively large height-adjustable electric base. Expandable widths and multiple worksurface options ensure the right fit for your space.

FEATURES

- **Integrated:** Includes programmable four-position LED handset and cable manager.
- **Electric Lift:** Quad-sync motors allow for a 350 lb. lift capacity, which raises at 1.2" per second.
- **Smart:** Anti-collision safety sensor prevents accidents.
- **A Safe Space™ Product:** Easy to wipe down and disinfect between users.

SPECIFICATIONS

Finishes

Black
BK

Dimensions

Height Range: 27.25" - 46.75"
Width Options: 42" - 74"

Part Numbers

HAT4-MID-L- _ _

WARRANTY

Motor & Parts: 12 Years
Craftsmanship: Lifetime



HAT POWER & DATA BEAM



Keep your workspace organized and powered up with this convenient plug-in track. Whether you need power, data, or voice to do your job, this accessory allows for a clean custom set-up.

The lightweight Power Data Beam keeps wires off the floor and nestled neatly under your worksurface. Its built-in BYRNE 8 TRAC power system includes a four-circuit, eight-wire electrical system. The beam also allows for integrated divider installation.

FEATURES

- **Quick-Mount:** Clips for the power trac come pre-installed.
- **Configurable Layout:** 180°, 120°, L, T and X connector post options available.
- **Easy Install:** With only seven parts, this beam is quickly and easily put together.
- **Adaptable:** Includes voice and data cover plates, as well as data jack adapter kit.
- **Power:** All state electrical regulations can be met.

SPECIFICATIONS

Finishes

In-Stock:

- White
WH
- Silver
SI
- Black
BK

Dimensions

Frame Height: 23"
Width Options: 36", 48", 60" and 72"

WARRANTY

Electrical & Mechanical Components: 7 Years
Craftsmanship: Lifetime



S-COLLECTION SE 2-LEG, 2-STAGE



The SE 2 Leg, 2-Stage desking solution exemplifies the Danish design principles of simplicity and functionality. This electric, height-adjustable table offers a slightly smaller height range than the 3-Stage, but with equal weight capacity and visual configurations.

FEATURES

- **Adjustable:** Electric motor allows for a 350 lb. lift capacity, raising at 1.5" per second.
- **Smart:** Standard, software-based collision detection mitigates damage.
- **Certified:** Meets ANSI/BIFMA standards and is ETL listed to UL 962.
- **A Safe Space™ Product:** Easily reconfigured to allow for social distancing in the workplace.

SPECIFICATIONS

Frame Finishes

- White
W
- Silver
S
- Black
B

Worksurfaces

See page 47 for available worksurfaces

Height Range: 27.1" - 45.6"

Size Options: 36" - 96" W x 24" - 30" D

Frame-Only Weight Capacity: 350 lbs.

Adjustability: Electric Control

Speed: 1.5" Per Second

Max Power Draw: 120 V, 60 Hz, 5 A

Standby Power: 0.1W

Special Features: Soft Stop

Switch: Digital Switch

WARRANTY

Motor & Parts: 12 Years

Craftsmanship: Lifetime



S-COLLECTION SX 2-LEG, 3-STAGE



The SX 2-Leg, 3-Stage offers S-Collection's largest height range. This electric sit-to-stand table comes in a 2-leg configuration, with all of the bells and whistles we could fit onto one worksurface.

FEATURES

- **Adjustable:** Electric motor allows for a 350 lb. lift capacity, raising at 1.5" per second.
- **Smart:** Premium, hardware-based collision detection mitigates damage.
- **Certified:** Meets ANSI/BIFMA standards and is ETL listed to UL 962.
- **A Safe Space™ Product:** Easily reconfigured to allow for social distancing in the workplace.

SPECIFICATIONS

Frame Finishes

- White
W
- Silver
S
- Black
B

Height Range: 22.2" - 48.7"
Size Options: 36" - 96" W x 24" - 30" D
Frame-Only Weight Capacity: 350 lbs.
Adjustability: Electric Control
Speed: 1.5" Per Second
Max Power Draw: 120 V, 60 Hz, 5 A
Standby Power: 0.1W
Special Features: Soft Stop
Switch: Digital Switch

Worksurfaces

See page 47 for available worksurfaces

WARRANTY

Motor & Parts: 12 Years
 Craftsmanship: Lifetime



S-COLLECTION 3-LEG



Office planning has never been easier. Our S-Collection 3-Leg offers beautifully comfortable, flexible, and ergonomic solutions for your work environment.

Our 3-leg electric desks are available in both 2 and 3-stage height adjustability, along with a multitude of opportunities for customization. No matter what your requirements, S-Collection can be configured to satisfy.

FEATURES

- **Adjustable:** Electric motor allows for a 525 lb. lift capacity, raising at 1.5" per second.
- **Smart:** Standard, software-based collision detection mitigates damage.
- **Certified:** Meets ANSI/BIFMA standards and is ETL listed to UL 962.
- **A Safe Space™ Product:** Easily reconfigured to allow for social distancing in the workplace.

SPECIFICATIONS

Frame Finishes

- White
W
- Silver
S
- Black
B

Worksurfaces

See page 47 for available worksurfaces

2-Stage

Height Range: 27.1" - 45.6"
Anti-Collision: Standard Collision Detection Software

3-Stage

Height Range: 22.2" - 48.7"
Anti-Collision: Premium Collision Detection Sensor

Adjustability: Electric Control

Speed: 1.5" Per Second

Frame-Only Weight Capacity: 525 lbs.

Max Power Draw: 120 V, 60 Hz, 5 A

Standby Power: 0.1W

Special Features: Soft Stop

Switch: Digital Switch

WARRANTY

Motor & Parts: 12 Years

Craftsmanship: Lifetime



S-COLLECTION PANEL MOUNTED



Our panel integration solution is designed to create a seamless union between the S-Collection and panel systems. Brackets introduce a safe locking solution into the system by staying free from pinch points and avoiding interference with existing furniture.

Panel Mount integration is available for new systems as well as pre-installed units. Working with existing panels presents a cost-efficient option and reduces waste for a more environmentally friendly approach. Integration also creates space below the surface by allowing for the use of smaller feet. The recessed frame design is perfect for adding a storage pedestal or CPU.

FEATURES

- **Adjustable:** Electric motor allows for a 350 lb. lift capacity, raising at 1.5" per second.
- **Smart:** Premium, hardware-based collision detection mitigates damage.
- **Safe:** Brackets keep the table in a fixed lateral position, maintaining important pinch gaps around the perimeter of the desk to avoid damage or injury.
- **A Safe Space™ Product:** Easily cleaned and disinfected between users.

SPECIFICATIONS

Finishes

- White
W
- Silver
S
- Black
B

2-Stage

Height Range: 27.1" - 45.6"

3-Stage

Height Range: 22.2" - 48.7"

Adjustability: Electric Control

Speed: 1.5" Per Second

Weight Capacity: 350 lbs.

Max Power Draw: 120 V, 60 Hz, 5 A

Standby Power: 0.1W

Special Features: Soft Stop

Switch: Digital Switch

WARRANTY

Motor & Parts: 12 Years

Craftsmanship: Lifetime



S-COLLECTION WALL MOUNTED



This iteration makes S-Collection a permanent fixture in your place of work. Secure your new electric, height-adjustable table to the wall and transform dead space into a useful touchdown worksurface.

Wall Mounted takes all of the coveted features of our high-end electric desking solution and transforms it into a mounted worksurface. Choose your shape, finishes, and optional features and enjoy the benefits of height adjustability.

FEATURES

- **Adjustable:** Electric motor allows for a 250 lb. lift capacity, raising at 1.5" per second.
- **Smart:** Premium, hardware-based collision detection mitigates damage.
- **Certified:** Meets ANSI/BIFMA standards.
- **A Safe Space™ Product:** Easily cleaned and disinfected between users.

SPECIFICATIONS

Frame Finishes

- White
W
- Silver
S
- Black
B

Worksurfaces

See page 47 for available worksurfaces

SE, 2-Stage

Height Range: 30.1" - 48.6"
(with 1.125"-thick worksurface and placed 3" above the floor)

SX, 3-Stage

Height Range: 25.2" - 51.7"
(with 1.125"-thick worksurface and placed 3" above the floor)

Adjustability: Electric Control

Speed: 1.5" Per Second

Frame-Only Weight Capacity: 250 lbs.

Max Power Draw: 120 V, 60 Hz, 5 A

Standby Power: 0.1W

Special Features: Soft Stop

Switch Options: Digital Switch

WARRANTY

Motor & Parts: 12 Years

Craftsmanship: Lifetime



FIELLØ®



Sleek and sophisticated, Fiellø's Danish roots inspire the simplistic elegance of its fabrication. Fiellø's minimalist approach expresses itself in clean lines, cylindrical legs, and low-profile feet that all speak to the intent of the architectural experience.

HAT Collective collaborated with Gensler, serving as product design consultant, for Fiellø.

Product Design Consultant **Gensler**

FEATURES

- **Convenient:** Thoughtful features like a simple drawer or bag hook, will make you feel like Fiellø was made just for you.
- **Safe:** Features soft stop and advanced collision detection, ensuring safe adjustability.
- **Robust:** Meets ANSI/BIFMA standards.
- **Smart:** Choose Bluetooth® Control for the ultimate in technological workspace integration.

SPECIFICATIONS

Metal

- White W
- Silver S
- Black B

Worksurfaces

- Linen
- Charcoal
- Feather
- Black*
- Platinum*

Panels - Recycled PET

- Oatmeal FOA
- Night FNI
- Latte FLA
- Black FBL
- Pebble FPE

Panels - Wood Veneer

- Oak WO
- Walnut WW

Drawer

- Oak WO
- Walnut WW

Frame-Only Height Range: 21.1" - 47.6"

Adjustability: Electric Control

Worksurface Sizes: 60" W x 30" D, 72" W x 30" D

Feet Depth: 27.5"

Panel Heights: Modesty, Privacy

Frame-Only Weight Capacity: 350 lbs.

Speed: 1.5" per second

Standby Power: < 0.1W

Max Power Draw: 120 V, 60 Hz, 2.5 A

Environmental Consideration: PVC-Free Frame Components

Worksurfaces made from Clean Air Gold certified materials

WARRANTY

Motor & Parts: 12 Years

Craftsmanship: Lifetime



ELLE



This elegant, Parsons-style table offers unmatched stability compared to other 4-leg, height-adjustable models. Elle is available in four different surface-mounting conditions, for a tailored design and fit. The optional cable tray makes power management easy, while the adjustable crossbar allows for simple reconfiguration.

FEATURES

- **Electric:** The advanced control switch allows you to intuitively raise or lower the desk with ease.
- **Safe:** Elle features soft stop, ensuring safe adjustability.
- **A Safe Space™ Product:** Easily cleaned and disinfected between users.

SPECIFICATIONS

Finishes

- White
W
- Silver
S
- Black
B

Worksurfaces

See page 48 for available worksurfaces

- Top Options:** Top Mounted Single Surface
 Enshrined Mounted Single Surface
 Top Mounted Split Surface
 Enshrined Mounted Split Surface

Worksurface Angle: Rectangular

- Enshrined Surface Height Range:** 27" - 46.7" (including 1" worksurface)
- Top Mounted Surface Height Range:** 28" - 47.7" (including 1" worksurface)
- Standard Depth:** 30"
- Standard Width:** 60", 72"
- Frame-Only Weight Capacity:** 400 lbs.
- Adjustability:** Electric Control
- Speed:** 1.5" per second
- Standby Power:** 0.08W
- Environmental Consideration:** PVC-Free Frame Components
- Switch:** Digital Switch
- Special Standard Features:** Soft Stop, Optional Battery Pack Upgrade



Enshrined and top mounted with single surface



Enshrined and top mounted with split surface

WARRANTY

Motor & Parts: 12 Years
 Craftsmanship: Lifetime



ELLE STATIC

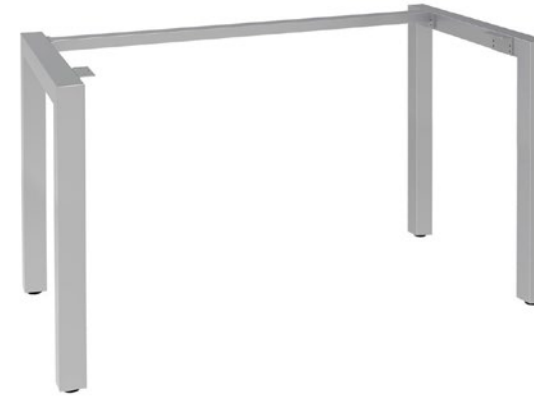

Standing or sitting, the static Elle tables are flexible and functional for any space. Designed and manufactured in Denmark, the static Elle tables are part of the Elle Collection, which include a family of height adjustable individual and group work tables. The static Elle tables are available in either fixed-height sitting or fixed-height standing. Each piece in the collection is fully customizable to work your way.

Team interaction has never been more important. Our Elle Collection group work static tables are the perfect solution to help your team connect.

FEATURES

- **Static:** Choose from 28" sitting height or 42" standing height.
- **Collaborate:** Ideal for a flexible collaboration spaces or personal workstation.
- **A Safe Space™ Product:** Easily cleaned and disinfected between users.

SPECIFICATIONS

Finishes

- White
W
- Silver
S
- Black
B

Static Heights: 28", 42"

Standard Depth: 24", 30"

Standard Width: 60", 72"

Frame-Only Weight Capacity: 400 lbs.

Environmental Consideration:
PVC-Free Frame Components

WARRANTY

Parts: 12 Years
Craftsmanship: Lifetime



ELLEHAVEN™



Designed and manufactured in Denmark, Ellehaven's sleek and sophisticated design is only the beginning.

Ellehaven's electric lift can be powered by cable or battery. This built-in flexibility makes this height-adjustable table suitable for any layout, while maintaining your environment's aesthetics. Optional cable tray holds batteries and wires in place for added organization.

FEATURES

- **Electric:** At the push of a button, electric power will lift Ellehaven to your preferred height at a rate of 1.5" per second.
- **Convenient:** The choice of cable or battery power makes rearrangements easy.
- **A Safe Space™ Product:** Easily cleaned and disinfected between users.

SPECIFICATIONS

Finishes

- White
W
- Silver
S
- Black
B

Worksurfaces

See page 49 for available worksurfaces

Top Finishes: Laminate

Worksurface Angle: Rectangular

Height Range: 28" - 47.7"

Standard Depths: 36", 42", 48"

Standard Widths: 84", 96", 108", 120"

Frame-Only Weight Capacity: 450 lbs.

Adjustability: Electric Control

Speed: 1.5" per second

Standby Power: 0.08W

Environmental Consideration:

PVC-Free Frame Components

Switch: Digital Switch

Special Standard Features: Soft Stop

WARRANTY

Motor & Parts: 12 Years

Craftsmanship: Lifetime



M-SERIES FREESTANDING



Whether as a stand-alone workstation, in a pod layout, or as a touch-down surface, the height-adjustable M-Series flexes to work for you. This customizable table is available in three models and a variety of specifications, which means it fits wherever you need it. Choose your ideal worksurface shape to get the base and top combo that best suits your needs.

FEATURES

- **Ergonomic:** The unique Constant Force Spring technology allows smooth and consistent movement.
- **Customized:** M-Series is available in multiple weight capacities, worksurface sizes, and base designs.
- **Secure:** A safety brake with integrated locking mechanism keeps the table in place.
- **A Safe Space™ Product:** Easily cleaned and disinfected between users.

SPECIFICATIONS

Finishes

- White
W
- Silver
S
- Black
B

Worksurfaces

See page 50 for available worksurfaces

Height Range: 27.6" - 44.1"

Adjustability: Constant Force Spring

Frame-Only Weight Capacity:

Supports a range of 15 - 105 lbs.
(Column available in Ultralight, Light, Medium, and Heavy)

Worksurface Angle: Rectangular

Worksurface Range:
30" - 60" x 24" - 30"

Base Shapes: Organic H, Organic X

WARRANTY

Parts: 12 Years

Craftsmanship: Lifetime



M-SERIES TRIPOD & QUAD



Team up with an M-Series Tripod or Quad combo for comfortable, productive break-out meetings.

These multi-seater desks adapt the best of M-Series for team sessions. Meetings shouldn't inhibit your ability to work ergonomically.

FEATURES

- **Ergonomic:** Constant Force height adjustment makes it easy to brainstorm in comfort.
- **Integrated:** The clever worksurface shapes fit together to take up less space.
- **Secure:** A safety brake with integrated locking mechanism keeps the table in place.
- **A Safe Space™ Product:** Easily cleaned and disinfected between users.

SPECIFICATIONS

Finishes

- White
W
- Silver
S
- Black
B

Worksurfaces

See page 51 for available worksurfaces

M-Tripod

Seats: 3
 Worksurface Shape: 120°
 Worksurface Weight: 43+ lbs.
 (Surface size contingent)

M-Quad

Seats: 4
 Worksurface Shape: 90°
 Worksurface Weight: 35+ lbs.
 (Surface size contingent)

Height Range: 27.6" - 44.1"
 (including 1" thick surface)

Worksurface Size: 36" - 40" x 18" - 24"

Frame-Only Weight Capacity:
 Supports a range of 15 - 105 lbs.
 (Column available in Ultralight, Light, Medium, Heavy)

Adjustability: Constant Force Spring

Wire Management: Included

WARRANTY

Parts: 12 Years
 Craftsmanship: Lifetime



M-SERIES NESTING



M-Series Nesting combines collaborative, mobile desking with the benefits of sit-to-stand. The unique flower petal design enables quick room reconfiguration, from training rows to huddle groups, and nesting saves space.

Nesting desktops can even be ordered with dry-erase white board laminate, allowing users to jot notes during a meeting, flip the top to 90 degrees, and present on their own personal white board. Your training room has now become an ergonomic, innovative, and flexible resource for the entire team.

FEATURES

- **Ergonomic:** A manually-operated mechanism quickly adjusts height without the use of electric power.
- **Smart:** Base incline allows easy nesting for maximum space-saving, without compromising aesthetics or functionality.
- **Innovative:** Movable desktop doubles as a personal presentation white board.
- **A Safe Space™ Product:** Easily cleaned and disinfected between users.



Easily reconfigure your space



Maximizes space without compromising aesthetics or functionality

SPECIFICATIONS

Finishes

- White
W
- Silver
S
- Black
B

Worksurface Shape: Petal

Height Range: 28.6" - 45.1"

Angles: 0°, 15°, 22.5°, 45°, or 90°

Frame-Only Weight Capacity:
Supports a range of 15 - 35 lbs.
(Column available in Light)

Adjustability: Constant Force Spring

Worksurfaces

See page 52 for available worksurfaces

WARRANTY

Parts: 12 Years

Craftsmanship: Lifetime



M-SERIES WALL MOUNT



This wall-mounted desking solution takes the beauty of the M-Series and adds a tilting mechanism.

Perfect for small spaces, hospitals, and lobbies, the Wall Mount delivers an ergonomic, height-adjustable touchdown area. Wall Mount is also available with added tilt for easy adjustability in a small mounting footprint.

FEATURES

- **Ergonomic:** A manually-operated mechanism quickly adjusts height without the use of electric power.
- **Storable:** Tilt allows for a full vertical bend between top and column, making each desk easy to flip up and out of the way.
- **Secure:** A safety brake with integrated locking mechanism keeps the table in place.
- **A Safe Space™ Product:** Easily cleaned and disinfected between users.

SPECIFICATIONS

Finishes

- White
W
- Silver
S
- Black
B

Worksurfaces

See page 53 for available worksurfaces

Height Range: 29.4" - 45.9"
(including 1" thick surface and placed 3" above the floor)

Max Worksurface Width: 20" - 48"

Max Worksurface Depth: 18", 24"

Optional Tilt Angle: 0°, 15°, 22.5°, 45°, 90°

Frame-Only Weight Capacity:
Supports a range of 15 - 60 lbs.
(Column available in Ultralight and Light)

Adjustability: Constant Force Spring

WARRANTY

Parts: 12 Years

Craftsmanship: Lifetime



WORKSURFACES FOR MID HAT, HI HAT, L UNIT, HAT BENCHING, S-COLLECTION



Surfaces can be added to any base or bench in 17 standard sizes. Worksurface orders must include a corresponding base or bench.

SPECIFICATIONS

Finishes

In-Stock & Standard:

- Designer White
DW
- Manitoba Maple
MM
- Fawn Cypress
FC
- Pinnacle Walnut
PW

Shapes

Rectangular

Sizes

17 Standard Size Options Available

Rectangular:
Range from 24" x 24" to 30" x 72"

In-Stock

Designer White, Fawn Cypress,
Manitoba Maple, Pinnacle Walnut
30" x 48", 30" x 60", 30" x 72"

SHIPPING

- **In-Stock Items:** 1 - 24 units ship in 3 business days
- **Standard Items:** 15 - 249 units ship in 10 - 15 business days
250+ units call for lead time

WARRANTY

5 Years

WORKSURFACES FOR ELLE

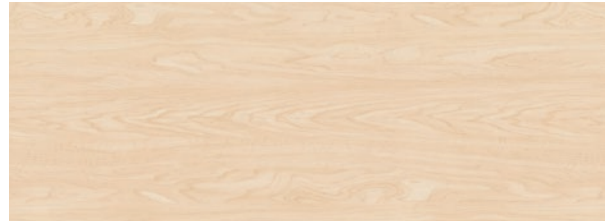

Elle worksurfaces can be added to any Elle base. Available in a variety of sizes and 4 standard finishes.

SPECIFICATIONS

Finishes

Standard:

- Designer White
DW
- Manitoba Maple
MM
- Fawn Cypress
FC
- Pinnacle Walnut
PW

Shapes

Rectangular

Sizes

Depth: 30"
Width: 60", 72"

Enhanced:
Contact your rep for enhanced worksurface requests which can include sizes and finishes.

SHIPPING

4 - 6 Weeks

WARRANTY

5 Years

WORKSURFACES FOR ELLEHAVEN

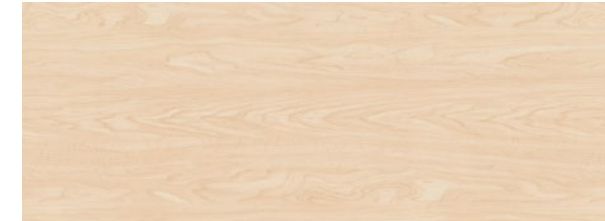

Ellehaven worksurfaces can be added to any Ellehaven base. Available in a variety of sizes and 4 standard finishes.

SPECIFICATIONS

Finishes

Standard:

- Designer White
DW
- Manitoba Maple
MM
- Fawn Cypress
FC
- Pinnacle Walnut
PW

Shapes

Rectangular

Sizes

Depth: 36", 42", 28"
Width: 84", 96", 108", 120"

Enhanced:
Contact your rep for enhanced worksurface requests which can include sizes and finishes.

SHIPPING

4 - 6 Weeks

WARRANTY

5 Years

WORKSURFACES FOR M-SERIES FREESTANDING

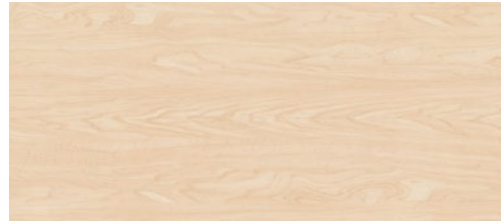

M-Series worksurfaces can be added to any M-Series Freestanding base. Available in a variety of sizes and 4 standard finishes.

SPECIFICATIONS

Finishes

Standard:

- Designer White
DW
- Manitoba Maple
MM
- Fawn Cypress
FC
- Pinnacle Walnut
PW

Shapes

Rectangular

Sizes

Depth: 24", 30"
Width: 36", 42", 48", 54", 60"

Enhanced:
Contact your rep for enhanced worksurface requests which can include sizes and finishes.

SHIPPING

4 - 6 Weeks

WARRANTY

5 Years

WORKSURFACES FOR M-SERIES TRIPOD & QUAD



90° or 120° curved worksurface



90° or 120° straight worksurface

M-Series worksurfaces can be added to any M-Series Tripod & Quad base. Available in a variety of sizes, shapes, and 4 standard finishes.

SPECIFICATIONS

Finishes

Standard:

- Designer White
DW
- Manitoba Maple
MM
- Fawn Cypress
FC
- Pinnacle Walnut
PW

Shapes

M-Series Tripod: 120° Curved or Straight
M-Series Quad: 90° Curved or Straight

Sizes

Depth: 18", 24"
Width: 36", 40"

Enhanced:
Contact your rep for enhanced worksurface requests which can include sizes and finishes.

SHIPPING

4 - 6 Weeks

WARRANTY

5 Years

WORKSURFACES M-SERIES NESTING



M-Series worksurfaces can be added to any M-Series Nesting. Available in 4 standard finishes.

SPECIFICATIONS

Finishes

Standard:

- Designer White
DW
- Manitoba Maple
MM
- Fawn Cypress
FC
- Pinnacle Walnut
PW

Shapes

Petal

Sizes

Depth: 22"
Width: 28"

Enhanced:
Contact your rep for enhanced worksurface requests which can include sizes and finishes.

SHIPPING

4 - 6 Weeks

WARRANTY

5 Years

WORKSURFACES M-SERIES WALL

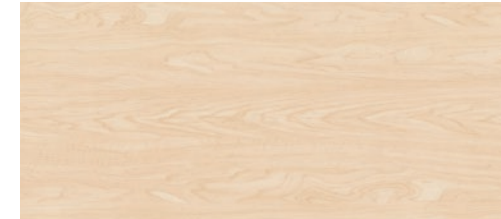

M-Series worksurfaces can be added to any M-Series Wall Mount. Available in a variety of sizes and 4 standard finishes.

SPECIFICATIONS

Finishes

Standard:

- Designer White
DW
- Manitoba Maple
MM
- Fawn Cypress
FC
- Pinnacle Walnut
PW

Shapes

Rectangular

Sizes

Depth: 18", 24"
Width: 20", 24", 30", 36", 42", 48"

Enhanced:
Contact your rep for enhanced worksurface requests which can include sizes and finishes.

SHIPPING

4 - 6 Weeks

WARRANTY

5 Years



IN-STOCK

WINSTON WORKSTATION®



Expansive workspace



Seamless height adjustment

This workstation instantly converts any desk into a sit stand workspace, boosting health and productivity. Winston is available in single, dual, triple, and quadruple monitor support.

The Winston's worksurface easily reserves room for a keyboard, mouse, and storage tray. Retrofit your existing desk into a healthy workspace with three easy mounting options. Winston Compact is ideal for users with limited space who want to take advantage of a healthy sit-stand workstation.

FEATURES

- **Stability:** Features an overall height adjust range of 17" and a locking cylinder to keep the workstation in place.
- **Easy:** Retrofit your existing desk with freestanding, desk clamp, or thru-desk options.
- **Organized:** Clips in the column and beam keep cables out of the way.
- **Convenient:** Expansive worksurface and storage tray allows you to bring all necessities with you when you stand.
- **A Safe Space™ Product:** Can be easily disinfected between users.

SPECIFICATIONS

Finishes

- Flat White
248
- Silver
124
- Vista Black
104

Dimensions

Height Adjustment: 17.1"
 Max Monitor Height: 37.6"
 Worksurface: 30" W x 23" D
 Compact Worksurface*: 30" W x 17" D
 Base: 20.7" W x 22" D

Weight Capacity:
 7 - 20 lbs. (Winston Single)
 10 - 26 lbs. (Winston Dual)
 15 - 36 lbs. (Winston Triple)
 24 - 40 lbs. (Winston Quad)

Part Numbers

WNST-1-__ (Winston Single)
 WNST-2-__ (Winston Dual)
 WNST-3-__ (Winston Triple)
 WNST-4-__ (Winston Quad)**

Max Screen Size:
 43" (Winston Single)
 27" (Winston Dual)
 24" (Winston Triple)
 24" (Winston Quad)

WARRANTY

5 Years

* Compact worksurface available, please speak with your rep for more information.

** Winston Quad is special order only.

● In-stock product ships within 3 business days.



WINSTON-E®



Winston-E is a responsive powered riser that takes the sit-stand conversation to a whole new level. The next-generation retrofit work surface with monitor arms is engineered for freedom of movement and is available in a single, dual, or triple monitor configuration.

Focal depth adjustment and independent movement keeps monitor at a comfortable, ergonomic level.

FEATURES

- **Easy:** Installers can get Winston-E from box to up-and-running in less than 20 minutes. No need to move or replace furniture.
- **Flexible:** Independent monitor movement enable easy screen sharing.
- **Convenient:** Large work surface and newly designed storage tray allow you to bring all necessities with you when standing.
- **A Safe Space™ Product:** Can be easily disinfected between users.

SPECIFICATIONS

Finishes

Grey Duotone
270

Dimensions

Height Adjustment: 18.4"
 Monitor Height Adjust Range: 12.6"
 Max Monitor Height: 37.6"
 Worksurface: 30" W x 22" D
 Compact Worksurface*: 30" W x 16" D
 Base: 16" W x 21" D
 Weight Capacity: Up to 40 lbs.
 Max Screen Size: 43" (Winston-E Single)
 30" (Winston-E Dual)
 24" (Winston-E Triple)

Part Numbers

WNSTE-1-270 (Winston-E Single)
 WNSTE-2-270 (Winston-E Dual)
 WNSTE-3-270 (Winston-E Triple)



Focal depth adjustment

Independent monitor height adjustment

WARRANTY

5 Years

* Compact work surface available, please speak with your rep for more information.
 ● In-stock product ships within 3 business days.



DIVIDERS

Create privacy in any open environment with our easy-to-install partitions. Dividers add spatial barriers and distinctive design to an office landscape, prioritizing both functionality and aesthetic. Choose from opaque or transparent, permanent or portable to take advantage of the protection, acoustic control, and flexibility provided by HAT Collective dividers.

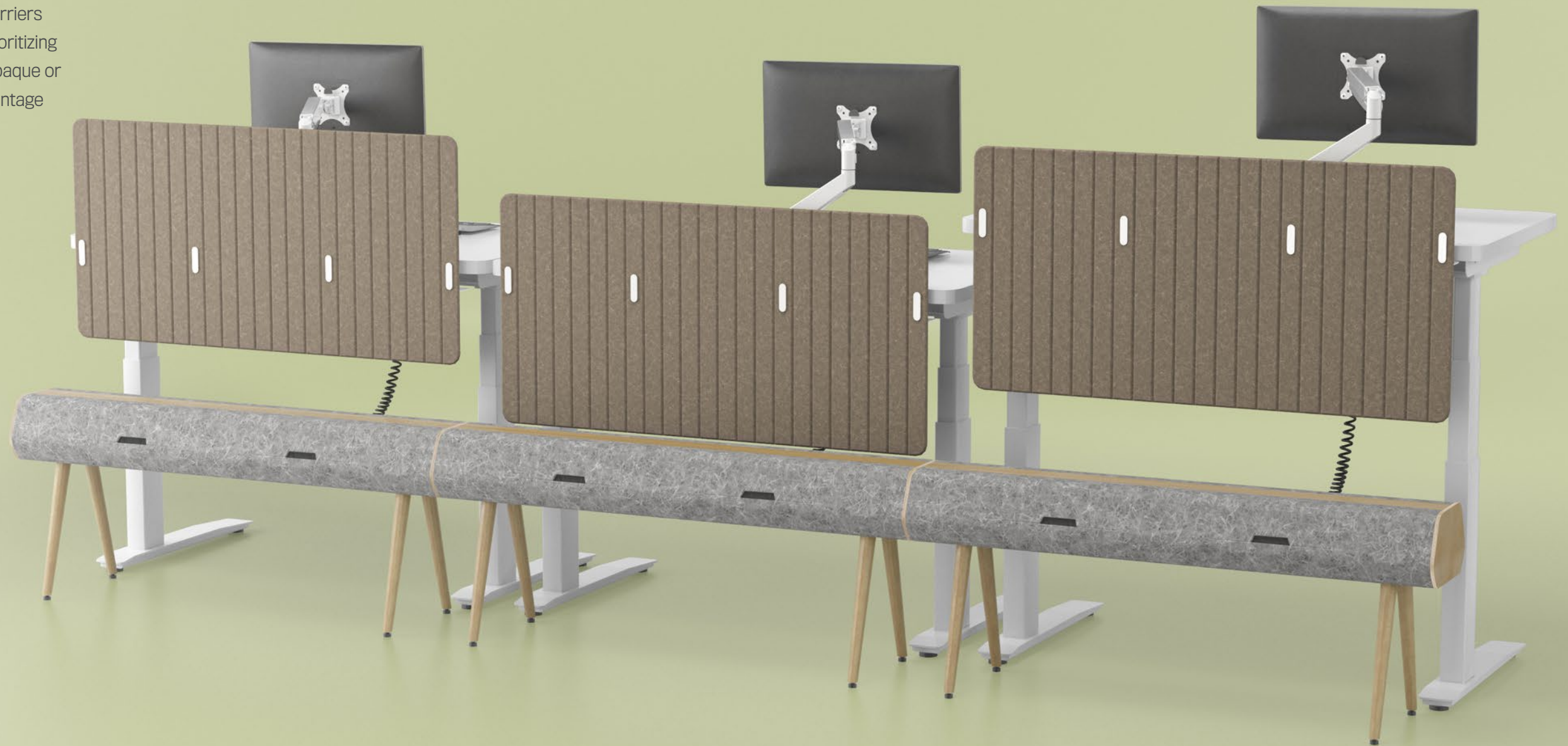



MESA SLIDE



Mesa dividers create privacy in any open environment. Easily install these partitions between workstations, adding distinctive design and a barrier of space to your office landscape.

To keep things quick and portable, look no further than Mesa Slide. Take privacy and protection with you, wherever you go.

FEATURES

- **Easy Install:** Simply slide the divider onto your desk surface to create privacy.
- **Portable:** Transfer your protective barrier by grabbing the slide and taking it with you to the cafeteria or a meeting.
- **Quiet:** Acoustical properties allow for noise reduction in open office floor plans.
- **Environment:** Made from 60% post-consumer recycled PE plastic water bottles, the 100% recyclable polyester fiber makes PET dividers the eco-friendly privacy solution.
- **A Safe Space™ Product:** The Mesa Slide enables social distancing and is easy to disinfect between users.

SPECIFICATIONS

Colors

In-Stock:

- Ash
ASH
- Slate
SLATE

Dimensions

Overall Height: 27.18"
 Above Desk Height: 24"
 Overall Depth: 26.5"
 Depth from Desk Edge: 24"
 Divider Thickness: 1.12"
 Compatibility: Designed for a 1.12" desk thickness (opening is 1.1")

Acoustics

.90 NRC rating

Part Numbers

SD-2424-_-_-_-_-



Available in Ash and Slate



Easily slides onto worksurface



MESA PET WRAP



For the ultimate in personal space, choose the Mesa PET Wrap. This divider dampens sound and cocoons your workspace on three sides, giving you the quiet space you need to get the job done.

FEATURES

- **Protective:** Wraps around three sides of your workstation, providing maximum privacy and protection.
- **Quiet:** Acoustical properties allow for noise reduction in open office floor plans.
- **Customizable:** Multiple sizes allow for easy integration into your current workstation configuration.
- **Environment:** Made from 60% post-consumer recycled PE plastic water bottles, the 100% recyclable polyester fiber makes PET dividers the eco-friendly privacy solution.
- **A Safe Space™ Product:** The Mesa PET Wrap enables social distancing and is easy to disinfect between users.

SPECIFICATIONS

Colors

In-Stock:

- Iced Grey
IG
- Charcoal
CH

Dimensions

Overall Height: 28"
 Above Desk Height: 24"
 Below Desk Height: 3"
 (assuming 1" desk thickness)
 Longest Length of Side: 23"
 Divider Thickness: .75"
 Compatibility: Clamps to desks .75" - 1.87"

Acoustics

.90 NRC rating

Part Numbers

WD-4828-_-_- (fits 48" W worksurface)
 WD-6028-_-_- (fits 60" W worksurface)
 WD-7228-_-_- (fits 60" W worksurface)*



Available in Iced Grey and Charcoal

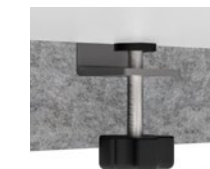

Clamps to worksurface

WARRANTY

5 Years

MESA ACRYLIC



Use the transparent Mesa Acrylic divider to control acoustics without obstructing visual space. This clever divider is also ideal for social distancing and allows for quick, easy cleaning to control the spread of infection.

FEATURES

- **Unobtrusive:** Increase privacy while maintaining visibility in an open office.
- **Customizable:** Multiple sizes allow for easy integration into your current workstation configuration.
- **Flexible:** Choose from surface or beam mount options.
- **A Safe Space™ Product:** Prevent spread of contaminants with easy-to-sanitize surface.

SPECIFICATIONS

Finishes

Standard:

 Frosted Acrylic

Dimensions

Acrylic Thickness: .25"

Surface Mounts: Clamps to desks .87 - 1.87" (66"+ widths ships with three clamps)

Standard: Heights: 12", 18", 24"

Standard: Widths: 24", 30", 36", 42", 48", 54", 60", 66", 72"

Part Numbers

ADD-_-_- (Surface Mounted)

HRAD-_-_- (Beam Mounted)

WARRANTY

5 Years



Mounts to surface or beam



PET DIVIDERS



Create privacy and reduce noise with eco-friendly PET dividers. With easy installation and a variety of mounting options, PET dividers transform workspaces into personal and quiet workstations.

FEATURES

- **Quiet:** Acoustical properties allow for noise reduction in open office floor plans.
- **Customizable:** Multiple sizes allow for easy integration into your current workstation configuration.
- **Flexible:** Choose from surface or beam mount options.
- **Environment:** Made from 60% post-consumer recycled PE plastic water bottles makes PET dividers the eco-friendly privacy solution.
- **A Safe Space™ Product:** Enables social distancing and is easy to disinfect between users.

SPECIFICATIONS

Colors

In-Stock:

 Ash
ASH

 Slate
SLATE

Standard:

Additional PET colors available, see page 128

Dimensions

Thickness: .75"

Surface Mounts: Clamps to desks .75 - 1.87" (66"+ widths ships with three clamps)

In-Stock Heights: 24"

In-Stock Widths: 48", 60"

Standard Heights: 12", 18", 24"

Standard Widths: 24", 30", 36", 42", 48", 54", 60", 66", 72"

Acoustics

.90 NRC rating

Part Numbers

In-Stock:

EDDI-PET-_-_-_- S (Surface Mounted)

EDDI-PET-_-_-_- B (Beam Mounted)

Standard:

EDD-PET-_-_- (Surface Mounted)

HRED-PET-_-_- (Beam Mounted)

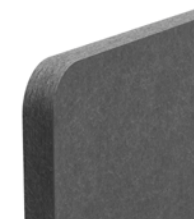

Sound absorbing material allows for focused work



Mounts to surface or beam

WARRANTY

5 Years

FABRIC DIVIDERS



Fabric dividers feature folded edges for a rounded, frameless look that offers a clean separation of space. Choose from a wide range of fabrics and grades.

FEATURES

- **Customizable:** Multiple sizes allow for easy integration into your current workstation configuration.
- **Quiet:** Acoustical properties allow for noise reduction in open office floor plans.
- **Flexible:** Choose from surface or beam mount options.
- **A Safe Space™ Product:** Enables social distancing and is easy to disinfect between users.

SPECIFICATIONS

Colors

See page 128

Dimensions

Thickness: .25"

Surface Mounts: Clamps to desks .75 - 1.87" (66"+ widths ships with three clamps)

Standard Heights: 12", 18", 24"

Standard Widths: 24", 30", 36", 42", 48", 54", 60", 66", 72"

Acoustics

.30 NRC rating

Part Numbers

Standard:

FDD-FF-___ (Surface Mounted)

HRFD-FF-___ (Beam Mounted)

WARRANTY

5 Years



Folded edges for a clean aesthetic



Mounts to surface or beam

WHITE BOARD DIVIDERS



Turn your dividers into a writable surface, ideal for making notes and sharing ideas.

FEATURES

- **Customizable:** Multiple sizes allow for easy integration into your current workstation configuration.
- **Flexible:** Choose from surface or beam mount options.
- **A Safe Space™ Product:** Prevent spread of contaminants with easy-to-sanitize surface.

SPECIFICATIONS

Finishes

Standard:

White Board
 WB

Dimensions

White Board Thickness: .7"

Standard: Heights: 12", 18", 24"

Standard: Widths: 24", 30", 36", 42", 48", 54", 60", 66", 72"

Surface Mounts: Clamps to desks .87 - 1.87" (66"+ widths ships with three clamps)

Part Numbers

WDD-WB-___ (Surface Mounted)

HRD-WB-___ (Beam Mounted)

WARRANTY

5 Years



Writable surface is easy to clean



Mounts to surface or beam

MODESTY PANEL



Add privacy below the desk with our modesty panel.

FEATURES

- **Customizable:** Multiple sizes allow for easy integration into your current workstation configuration.
- **A Safe Space™ Product:** Prevent spread of contaminants with easy-to-sanitize surface.

SPECIFICATIONS

Finishes

Standard:



Frosted Acrylic

Dimensions

Acrylic Thickness: .25"

Surface Mounts: Clamps to desks .87 - 1.87" (66"+ widths ships with three clamps)

Standard: Heights: 12", 18"

Standard: Widths: 24", 30", 36", 42", 48", 54", 60", 66", 72"

Part Numbers

AMP-_-_-

WARRANTY

5 Years

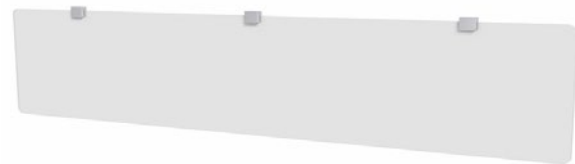

Mounts below worksurface

AURA



AURA (Adjustable Unlimited Recycled Acoustical) is more than your average screen. This environmentally conscious product offers visual and acoustical privacy using a unique mounting system, which allows for a tool-less adjustment. Just lift-up, flip, and drop the screen back into the mounts.

AURA's pleated design adds an aesthetic component and allows the screen to wrap around corners and adapt to various surface conditions. This adjustable screen is made with 60% post-consumer recycled content.

FEATURES

- **Stylish:** Functional and elegant, AURA offers separation, without interfering with workspace aesthetic.
- **Smart:** Designed to retrofit on existing or new workstations with unlimited partition options.
- **Certified:** Fire Rating UL tested ASTM E-84: Class A and LEED compliant.
- **A Safe Space™ Product:** AURA facilitates social distancing in the office.

SPECIFICATIONS

Colors



Night FNI



Slate FSL



Pebble FPE



Black FBL

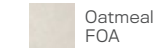

Oatmeal FOA



Latte FLA

Bracket Finishes



White W



Silver S



Black B

Dimensions

Height: 23"

Width: 46", 58", 70", 92"

Thickness: 0.35"

Full Modesty: 18" Below / 4" Above

Full Privacy: 9" Below / 13" Above

Material

60% Recycled Polyester Felt
Edge material: Exposed Felt

Acoustics

ASTM C 423: NRC [500hz] = .76 NRC
[1000hz] = 1.00Fire

Environmental Consideration

Made of 50% recycled water bottles.

Meets LEED compliancy standards.

Declare-Certified: Living Building Challenge Red List-Free.



Wraps around and adapts to various worksurfaces



Configures for privacy / modesty

WARRANTY

7 Years



MONITOR ARMS

Our sophisticated monitor arms provide ergonomics, space savings, and clever design. Here, you'll find one-touch adjustment, effortless movement, and sure-footed stability to support a multitude of screen configurations. Reclaim your desktop with our sleek mounting systems that are easy to install.



E5



Monitor arms must adapt to the needs of today's workers, as well as those of tomorrow in the evolving technology landscape. Meet E5 – a next gen monitor mounting system built for simplicity, efficiency, and compatibility. E5 ensures easy assembly and seamless future adaptability.

Whether you're mounting a 5, 20 or 40-pound monitor, one single E5 monitor arm has you covered. Not only does this eliminate the cost of installing an entirely new setup, but E5 makes the entire specification process easy and hassle free. The future never looked this good.

FEATURES

- **Fast Assembly:** Our innovative top-down mount, one tool installation, and convenient integrated tool storage makes E5 installation quick and easy.
- **Easy Adjustments:** Rotation stop adjustments are made externally for ease of use. No need to disassemble the arm, simply choose the amount of rotation from 90, 180, and 360 degrees.
- **Painless Configurability:** With 12 components and universal push-button quick connections, E5 offers infinite possibilities for customization.
- **Tension Indicator:** Built-in tension indicator allows the user to pre-counterbalance arms based on monitor weight prior to installation.
- **Quick-Disconnect:** Monitors can be easily changed with the quick-disconnect integrated on the VESA adapter.
- **Cable Management:** Thoughtful cable management routes cables down along the arm or pole keeping your workspace clutter free.
- **Compatible:** VESA-monitor compatible – 75mm & 100mm VESA adapter(s) included.

SPECIFICATIONS

Finishes

- White
WHT
- Silver
SLV
- Black
BLK
- Polished Aluminum
PWH

Mount: C-Clamp, Grommet

Compatibility: Up to 1.5" desk thickness

See pages 76-79 for additional specs

WARRANTY

15 Years

E5 DYNAMIC



E5 SINGLE DYNAMIC
Screen Size: Up to 49"
Weight Capacity: 0-25 lbs. or 5-45 lbs.
Part Number: E5-D1L-___ (0-25 lbs.)
 E5-D1-___ (5-45 lbs.)



E5 SINGLE DYNAMIC POLE
Screen Size: Up to 49"
Weight Capacity: 0-25 lbs.
Part Number: E5-P01SD-___



E5 DUAL CROSSBAR DYNAMIC
Screen Size: Up to 27"
Weight Capacity: 0-20 lbs. per monitor
Part Number: E5-D2C-___



E5 DUAL DYNAMIC POLE
Screen Size: Up to 32"
Weight Capacity: 0-25 lbs. per monitor
Part Number: E5-P02D-___

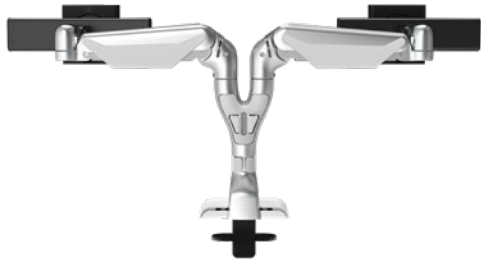

E5 DUAL DYNAMIC
Screen Size: Up to 32"
Weight Capacity: 0-25 lbs. per monitor
Part Number: E5-D2-___

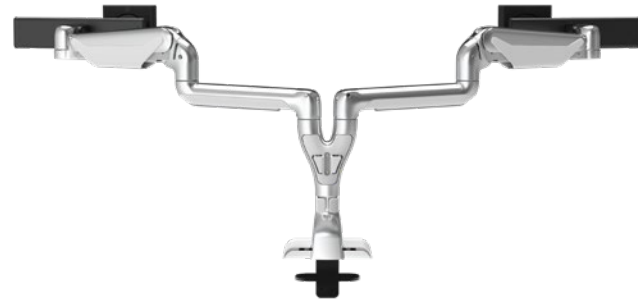

E5 DUAL DYNAMIC WIDE
Screen Size: Up to 44" bezel measured
Weight Capacity: 0-20 lbs. per monitor
Part Number: E5-D2SD-___



E5 DUAL DYNAMIC WIDE POLE
Screen Size: Up to 44" bezel measured
Weight Capacity: 0-20 lbs. per monitor
Part Number: E5-P02SD-___



E5 TRIPLE DYNAMIC POLE
Screen Size: Up to 27"
Weight Capacity: 0-20 lbs. per monitor
Part Number: E5-P03SD-___

E5 STATIC



E5 SINGLE STATIC POLE
Screen Size: Up to 49"
Weight Capacity: 0-45 lbs.
Part Number: E5-P01-___



E5 DUAL STATIC POLE
Screen Size: Up to 27"
Weight Capacity: 0-25 lbs. per monitor
Part Number: E5-P02S-___

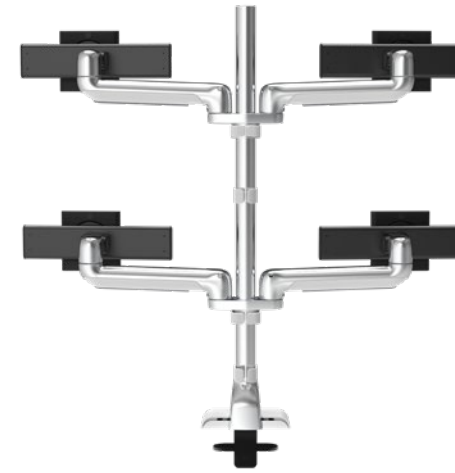

E5 TWO OVER TWO STATIC POLE
Screen Size: Up to 27"
Weight Capacity: 0-15 lbs. per monitor
Part Number: E5-P22S-___

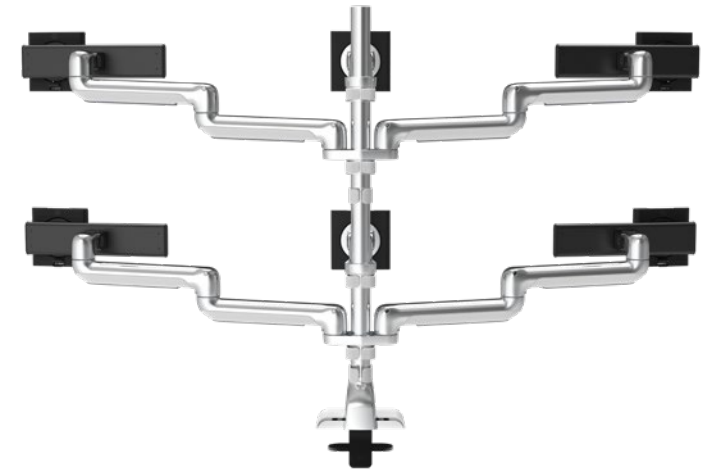

E5 THREE OVER THREE STATIC POLE
Screen Size: Up to 27"
Weight Capacity: 0-10 lbs. per monitor
Part Number: E5-P33SS-___



E5 TRIPLE STATIC POLE
Screen Size: Up to 27"
Weight Capacity: 0-20 lbs. per monitor
Part Number: E5-P03SS-___



E5 ONE OVER ONE STATIC POLE
Screen Size: Up to 49"
Weight Capacity: 0-30 lbs. per monitor
Part Number: E5-P11-___

E5 STATIC





IN-STOCK

E2



Dual arm features slides for maximum adjustability

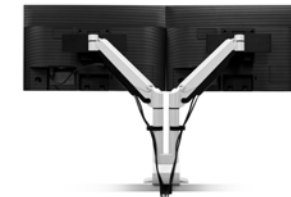

Cable management allows for a clutter-free workspace

An evolution in ergonomics. Introducing "E2", the next generation of the original Envoy monitor arm. E2 offers a polished design with maximum flexibility for user screen interaction. With a recent study citing 24% of workers experience neck pain, the E2 seeks to optimize user performance and adjustment control while eliminating the strain on neck muscles.

FEATURES

- **Sleek:** Clean lines and a modern silhouette provide a stylish profile for either home or office.
- **Ergonomic:** Allows monitors to be placed at an ergonomically correct distance from the user's eyes to increase comfort and productivity no matter where a person is working.
- **Dynamic:** Portrait-to-landscape rotation feature reduces stress on the neck and shoulders.
- **Easy:** Tension indicator allows the user to pre-counterbalance arms based on monitor weight prior to installation.
- **Compatible:** VESA-monitor compatible - 75mm & 100mm VESA adapters included.

SPECIFICATIONS

Finishes

Flat White	248
Silver	124
Vista Black	104

E2 Single

Screen Size: Up to 32"
 Height Adjustment: 13.3"
 Max Monitor Height: 20.6"
 Extension Range: 23.7"
 Rotation: 180° or 360° at base
 Weight Capacity:
 Flat Monitor: 2.2 - 20 lbs. (1 - 9 kg)
 Curved Monitor: Up to 16 lbs. (7.2 kg)
 Mount: C-Clamp, Grommet
 Compatibility: Up to 1.5" desk thickness

E2 Dual

Screen Size: Up to 27"
 Height Adjustment: 13"
 Max Monitor Height: 18.5"
 Width Adjustment Range: 17.5" - 28.5"
 Rotation: 180° or 360° at base
 Weight Capacity: 2 - 20 lbs. per monitor
 Mount: C-Clamp, Grommet
 Compatibility: Up to 1.5" desk thickness

Part Numbers

E2-1-___
 E2-2-___

Mount Conversion Kits

8524-FM-CK: Flexmount Conversion Kit
 8524-TM-CK: Thru-Desk Conversion Kit

WARRANTY

10 Years



E2 CONNEX

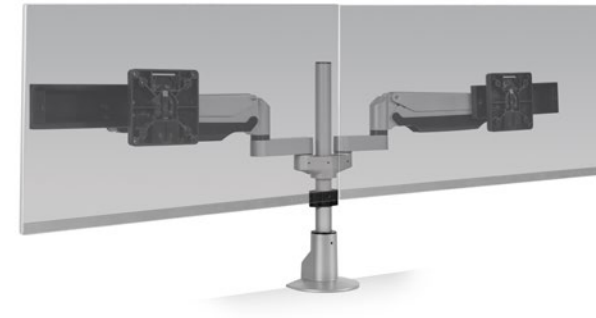



The E2 Connex monitor arm is designed to enhance interactions between you and your technology. With E2 Connex, you can add or remove monitors without compromising your original configuration. Choose between static or dynamic arms or add sliders for fine-tuned monitor adjustment. Easy to install, easy to change up, and easy to accessorize, the E2 Connex monitor arm helps to build a complete, individualized workspace.

FEATURES

- **Easy:** Quick install with our top-down clamp mount.
- **Modular:** Easily expand set-up to include more (or larger) monitors.
- **Adaptable:** Add or remove monitors without compromising the original configuration.
- **Convenient:** Our available Snap-On Charging Cap adds convenient, fast-charging USB ports to your workspace.
- **Compatible:** VESA-monitor compatible - 75mm & 100mm VESA adapter(s) included.

SPECIFICATIONS

Finishes

	Flat White 248
	Silver 124
	Vista Black 104

Mount: C-Clamp, Grommet

Compatibility: Up to 1.5" desk thickness

Mount Conversion Kits

8524-FM-CK: Flexmount Conversion Kit

8524-TM-CK: Thru-Desk Conversion Kit

See pages 84-85 for additional specs

WARRANTY

10 Years

E2 CONNEX DYNAMIC



E2 CONNEX DYNAMIC SINGLE

Screen Size: Any size within weight capacity

Weight Capacity:

Flat Monitor: 2.2 - 20 lbs.
Curved Monitor: Up to 16 lbs.

Part Number: E2-01-SD-___

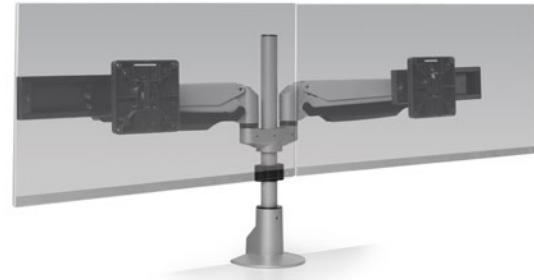

E2 CONNEX DYNAMIC DUAL

Screen Size: Up to 32" (bezel measured left to right)

Weight Capacity: 2.2 - 20 lbs. per monitor

Part Number: E2-02-D-___

E2 CONNEX STATIC

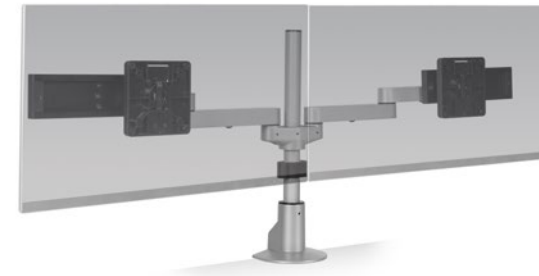

E2 CONNEX STATIC DUAL

Screen Size: Up to 37" (bezel measured left to right)

Weight Capacity: 2.2 - 20 lbs. per monitor

Part Number: E2-02-SS-___

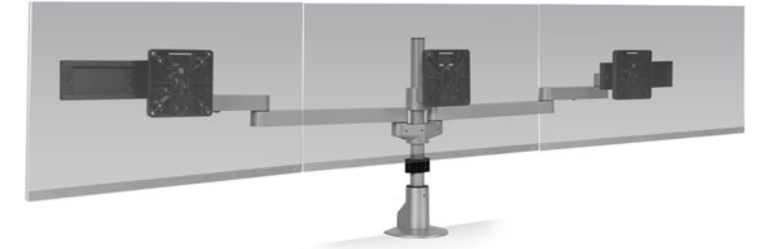

E2 CONNEX STATIC TRIPLE

Screen Size: Up to 27.5" (bezel measured left to right)

Weight Capacity: 2.2 - 20 lbs. per monitor

Part Number: E2-03-SSS-___

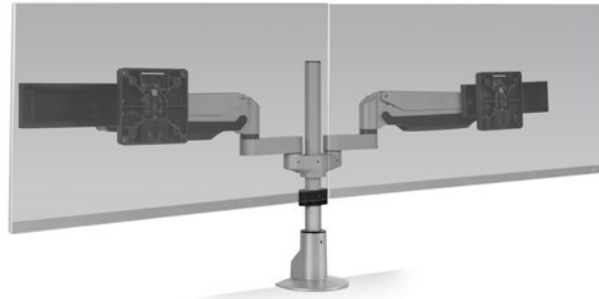

E2 CONNEX DYNAMIC DUAL WIDE

Screen Size: Up to 39" (bezel measured left to right)

Weight Capacity: 2.2 - 20 lbs. per monitor

Part Number: E2-02-SD-___

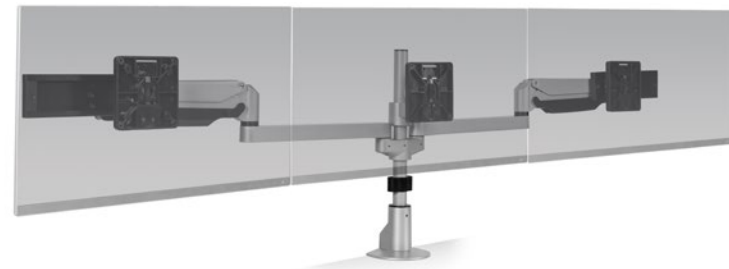

E2 CONNEX DYNAMIC TRIPLE

Screen Size: Up to 28.5" (bezel measured left to right)

Weight Capacity: 2.2 - 20 lbs. per monitor

Part Number: E2-03-SD-___

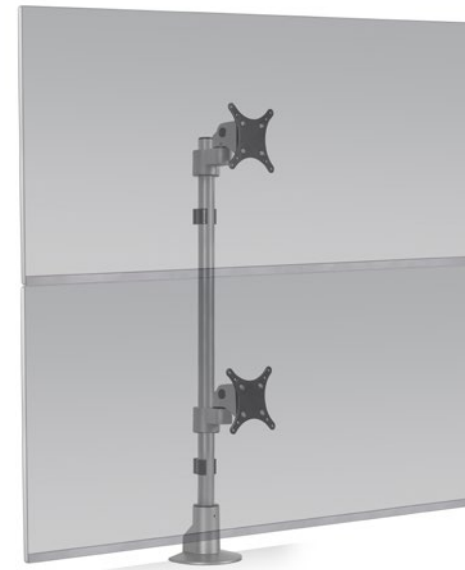

E2 CONNEX STATIC ONE OVER ONE

Screen Size:

One Flat Monitor: Up to 43" (16:9 aspect ratio)
Two Flat Monitors: Up to 49" (21:9 aspect ratio)
Two Curved Monitors: Up to 49" (21:9 aspect ratio)

Weight Capacity:

Flat Monitors: Up to 40 lbs. per monitor
Curved Monitors: 0 - 26.5 lbs. per monitor

Part Number: E2-11-HD-___





IN-STOCK

7000

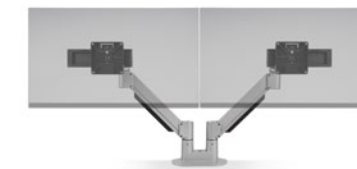

7000 Dual increases your productivity with dual monitor support



Instantly raise and lower the monitor with one hand

This articulating monitor mount enables you to reclaim your desktop while you work in greater ergonomic comfort. Suspend your monitor above your desk and take advantage of this arm's 360 degrees of rotation.

Need to mount two screens? 7000 Dual, our productivity-enhancing dual monitor mount, allows you to effortlessly reposition both monitors with just one hand.

FEATURES

- **Space-Saving:** Folds to occupy only 3" of space.
- **Responsive:** One-touch monitor adjustment.
- **Flexible:** Easily rotate monitor for portrait or landscape viewing.
- **Quick-Install:** 7000 Single installation is performed above desk for quick and easy set-up.
- **Compatible:** VESA-monitor compatible - 75mm & 100mm VESA adapter(s) included.

SPECIFICATIONS

Finishes

- Flat White 248
- Silver 124
- Vista Black 104

- 7000-800-___
Flat Monitor: 10 - 22 lbs. monitor
Curved Monitor: Up to 22 lbs.
- 7000-1000-___
Flat Monitor: 13- 28 lbs. monitor
Curved Monitor: Up to 22 lbs.
- 7000-1000-HD-___
Flat | Curved: 13-28 lbs. monitor

7000 Single

Screen Size:
Any size within weight capacity
Height Adjustment: 16"
Max Monitor Height: 17"
Extension Range: 23.4"
Rotation: 180° or 360° at base
Weight Capacity: 3 - 28 lbs.
Mount: C-Clamp, Grommet
Compatibility: Up to 1.5" desk thickness

7000 Single Part Numbers

- 7000-500-___
Flat Monitor: 3 - 10lbs. monitor
Curved Monitor: Up to 10 lbs.

7000 Dual

Screen Size:
Any size within weight capacity
Height Adjustment: 16"
Max Monitor Height: 19.8"
Extension Range: 23.4"
Rotation: 180° or 360° at base
Weight Capacity: 3 - 22 lbs. per monitor
Mount: C-Clamp, Grommet

7000 Dual Part Numbers

- 7000-2-500-SLD-___ (3-10 lbs. per monitor)
- 7000-2-800-SLD-___ (10-22 lbs. per monitor)

Mount Conversion Kits

- 8524-FM-CK: Flexmount Conversion Kit
- 8524-TM-CK: Thru-Desk Conversion Kit

WARRANTY

10 Years

In-stock product ships within 3 business days.

IN-STOCK

7000 CROSSBAR

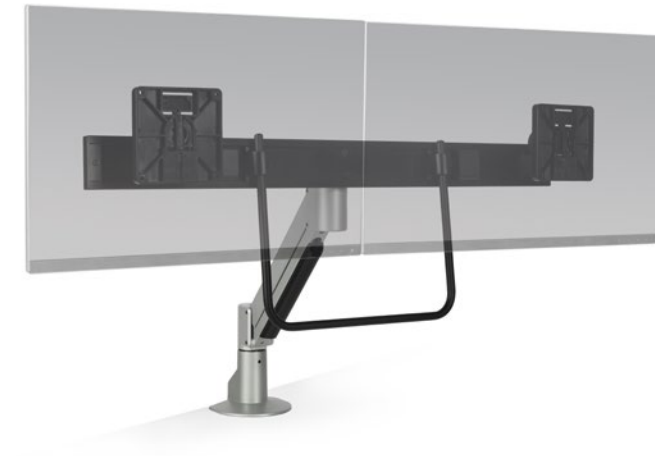

Built-in handle allows for easy monitor movement



Integrated cable management

7000 Dual Crossbar combines ergonomics and ease of use into one streamlined, functional monitor arm. The Dual Crossbar promotes a healthier posture and effortless movement of dual monitors. Experience increase performance and productivity with the convenience of the 7000 Dual Crossbar.

FEATURES

- **Space-Saving:** Mount dual monitors off a single arm to save valuable space.
- **Responsive:** Handle allows for movement of dual monitors in tandem for quick, easy repositioning.
- **Flexible:** Independent monitor movement: pivot, rotate, pan and tilt each monitor individually.
- **Quick:** Fast installation provided by top down clamp mount and quick-install tilter.
- **Compatible:** VESA-monitor compatible - 75mm & 100mm VESA adapters included.

SPECIFICATIONS

Finishes

Flat White	248
Silver	124
Vista Black	104

Dimensions

Screen Size: Up to 32"
 Extension Range: 17.8"
 Rotation: 180° or 360° at base
 Weight Capacity: 6 - 14 lbs. per monitor
 Mount: C-Clamp, Grommet

Part Numbers

7000-1-8537H-__

Mount Conversion Kits

8524-FM-CK: Flexmount Conversion Kit
 8524-TM-CK: Thru-Desk Conversion Kit

WARRANTY

10 Years



IN-STOCK

7500



The 7500 desk monitor mount features our patented HD tilter, a spring-assisted pivot for the monitor which makes adjustments remarkably easy, even with larger screens. Other features include internal cable management and unique joint bearings for ease of movement.

FEATURES

- **Effortless:** Instantly raise and lower your monitor with one handed repositioning.
- **Flexible:** Easily rotate flat panel monitor for portrait or landscape viewing.
- **Smooth:** Monitor arm includes our spring-assisted HD tilter for smoother monitor pivoting.
- **Compatible:** VESA-monitor compatible - 75mm & 100mm VESA adapter included.

SPECIFICATIONS

Finishes

- Flat White
248
- Silver
124
- Vista Black
104

Dimensions

Screen Size: Up to 43"
 Height Adjustment: 18"
 Extension Range: 27"
 Rotation: 360° at base
 Max Monitor Height: 19"
 Weight Capacity: 2 - 40 lbs.
 Mount: Desk Edge, Thru-Desk, Grommet, Wall, Reverse Wall, Side Bolt

Part Numbers

- 7500-500-__ (2-13 lbs. monitor)
- 7500-800-__ (6-21 lbs. monitor)
- 7500-1000-__ (8-27 lbs. monitor)
- 7500-1500-__ (12-40 lbs. monitor)



Effortless height adjustment



Integrated cable management



Space saving design

WARRANTY

10 Years



IN-STOCK

STAXX™

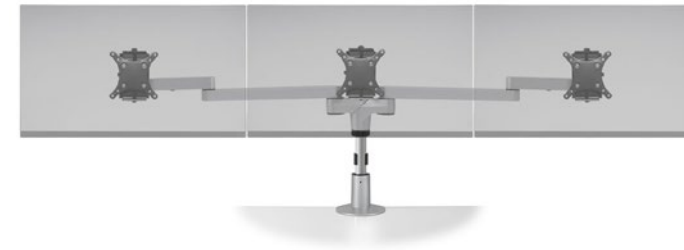

Designed for modularity, this groundbreaking display system can accommodate up to six monitors using a single mount. Staxx is a completely configurable pole-based solution allowing the addition of monitors by stacking more of the same parts on top of each other.

Flexible extension arms allow you to independently position the monitors for your perfect viewing angle. Staxx also comes in a Wide model, enabling even larger screen mounting capabilities.

FEATURES

- **Scalable:** Easy to install and reconfigure.
- **Capable:** Mount large screens stacked or side by side.
- **Customizable:** Available in a wide range of sizes and configurations.
- **Adjustable:** Flexible extension arms provide easy positioning and personalized viewing angles.
- **Compatible:** VESA-monitor compatible – 75mm & 100mm VESA adapter(s) included.

SPECIFICATIONS

Finishes

Flat White	248
Silver	124
Vista Black	104

Mount: C-Clamp, Grommet

Compatibility: Up to 1.5" desk thickness

Mount Conversion Kits

8524-FM-CK: Flexmount Conversion Kit

8524-TM-CK: Thru-Desk Conversion Kit

See pages 88-91 for additional specs

WARRANTY

10 Years

STAXX™ STANDARD



STAXX SINGLE
Screen Size: Up to 50"
Weight Capacity: Up to 30 lbs.
Part Number: STX-01S-___



STAXX ONE OVER ONE
Screen Size: Up to 30"
Weight Capacity: Up to 20 lbs. per monitor
Part Number: STX-11S-___

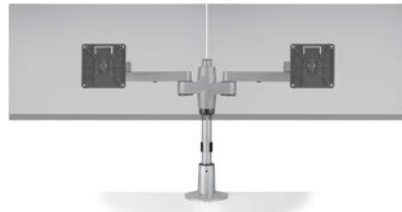

STAXX DUAL
Screen Size: Up to 24"
Weight Capacity: Up to 20 lbs. per monitor
Part Number: STX-02S-___

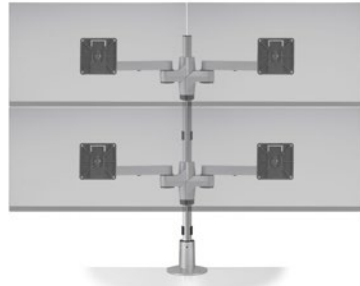

STAXX TWO OVER TWO
Screen Size: Up to 24"
Weight Capacity: Up to 15 lbs. per monitor
Part Number: STX-22S-___

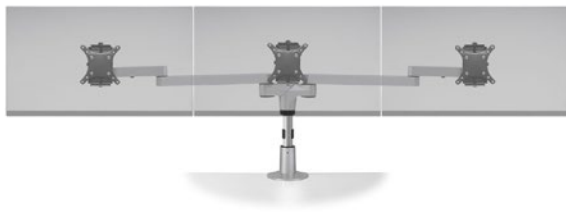

STAXX TRIPLE
Screen Size: Up to 24"
Weight Capacity: Up to 15 lbs. per monitor
Part Number: STX-03S-___

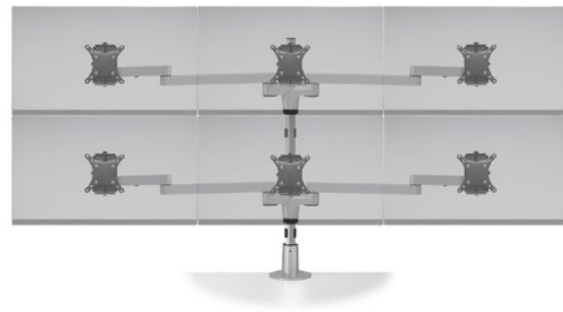

STAXX THREE OVER THREE
Screen Size: Up to 24"
Weight Capacity: Up to 10 lbs. per monitor
Part Number: STX-33S-___

STAXX™ WIDE

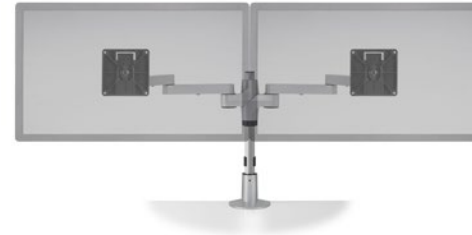

STAXX DUAL WIDE
Screen Size: 24" - 30"
Weight Capacity: Up to 20 lbs. per monitor
Part Number: STX-02W-___



STAXX TWO OVER TWO WIDE
Screen Size: 24" - 30"
Weight Capacity: Up to 15 lbs. per monitor
Part Number: STX-22W-___

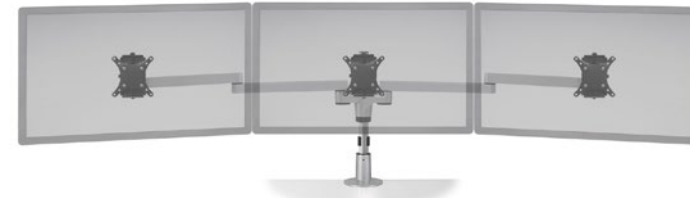

STAXX TRIPLE WIDE
Screen Size: 24" - 30"
Weight Capacity: Up to 15 lbs. per monitor
Part Number: STX-03W-___

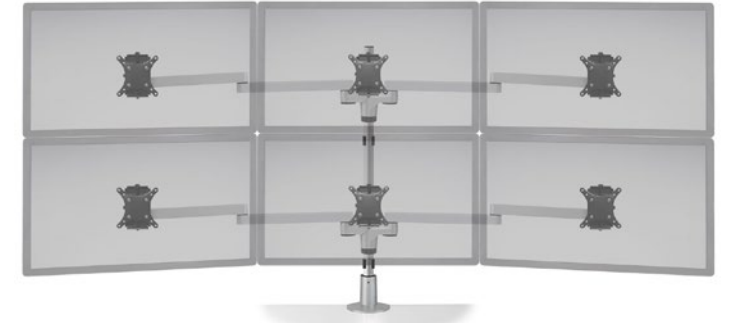

STAXX THREE OVER THREE WIDE
Screen Size: 24" - 30"
Weight Capacity: Up to 10 lbs. per monitor
Part Number: STX-33W-___

STAXX™ ARTICULATING



STAXX DUAL ARTICULATING
Screen Size: Up to 27"
Weight Capacity:
 10 - 23 lbs. per monitor (STX-450-___)
 3 - 10 lbs. per monitor (STX-500-___)
 7 - 17 lbs. per monitor (STX-600-___)
 10 - 22 lbs. per monitor (STX-800-___)
 13 - 28 lbs. per monitor (STX-1000-___)



STAXX DUAL ARTICULATING w/LAPTOP HOLDER
Screen Size: Up to 27"
Weight Capacity:
Monitor:
 10 - 23 lbs. (STX-450-8510-___)
 3 - 10 lbs. (STX-500-8510-___)
 7 - 17 lbs. (STX-600-8510-___)
 10 - 22 lbs. (STX-800-8510-___)
 13 - 28 lbs. (STX-1000-8510-___)
Laptop:
 3 - 13.5 lbs.

STAXX™ WITH SLIDERS

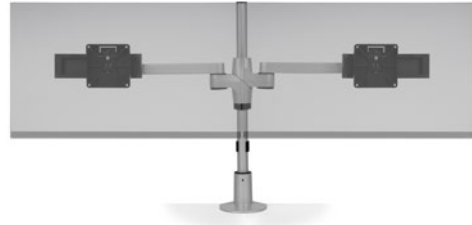

STAXX DUAL WITH SLIDERS

Screen Size: Up to 27" per monitor

Weight Capacity: Up to 20 lbs. per monitor

Part Number: STX-02-SLD-__

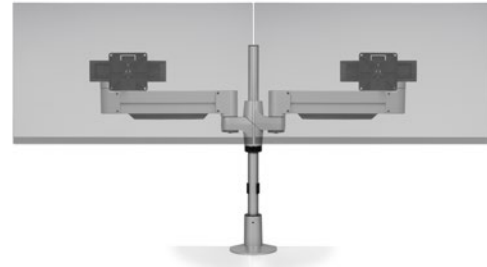

STAXX DUAL ARTICULATING WITH SLIDERS

Screen Size: Up to 27" per monitor

Weight Capacity:

3 - 10 lbs. per monitor (STX-2-500-SLD-__)

10 - 22 lbs. per monitor (STX-2-800-SLD-__)

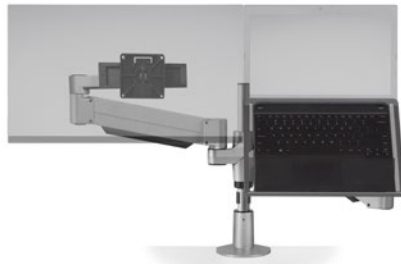

**STAXX DUAL ARTICULATING
w/LAPTOP HOLDER AND SLIDER**

Screen Size: Up to 27" per monitor

Weight Capacity:

Monitor:

3 - 10 lbs. (STX-2-500-8510-SLD-__)

10 - 22 lbs. (STX-2-800-8510-SLD-__)

Laptop:

3 - 13.5 lbs.

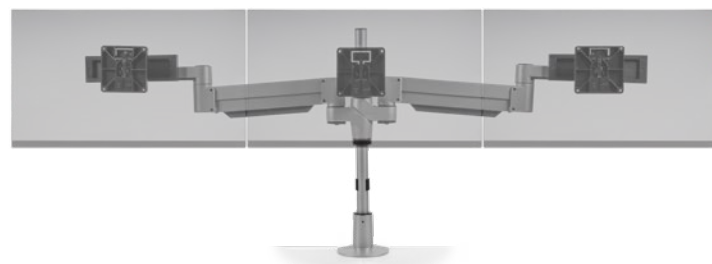

STAXX TRIPLE ARTICULATING WITH SLIDERS

Screen Size: Up to 27" per monitor

Weight Capacity:

3 - 10 lbs. per monitor (STX-3S-500-SLD-__)

10 - 22 lbs. per monitor (STX-3S-800-SLD-__)





STORAGE

Stay organized and keep your belongings secure with HAT storage units. Our pedestals, lockers and credenzas are heavy-duty, lockable, and comfortably accommodate your office supplies. Slide your mobile storage unit underneath your worksurface for easy, out-of-the-way access.





IN-STOCK

HAT MOBILE PEDESTALS



Mobile Pedestal Slim



Mobile Pedestal with optional cushion



Keep your belongings organized and secure in a convenient storage unit on wheels. These heavy duty steel pedestals come in two sizes and both include full-extension, lockable drawers.

Additional features include a pencil tray and filing capabilities, for both letter and legal paper sizes. Slide your mobile pedestal underneath your worksurface for easy access.

FEATURES

- **Secure:** Key-alike locking capabilities available for personal security.
- **Smart:** Anti-tipping counterweight and locking casters included.
- **Mobile:** The design includes a pull handle for easy moving.
- **Customizable:** Add an optional seat cushion – available in a wide variety of colors.
- **A Safe Space™ Product:** Easily reconfigured to allow for social distancing in the workplace.

SPECIFICATIONS

Finishes

- White
WH
- Silver
SI
- Black
BK

Cushion Colors

- In-Stock:
- Charcoal
CH

Standard:
Additional cushion colors available,
see page 129

Dimensions

Pedestals:
Slim: 10.6" W x 22" D x 21" H
Mobile: 15" W x 22" D x 21" H

Cushions:
Slim: 10" W x 22" D x 1.5" H
Mobile: 15" W x 22" D x 1.5" H

Part Numbers

Pedestals:
MPEDBF-10-__ (Slim)
MPEDBF-15-__ (Mobile)

Cushions:
MPEDCUS-10-__ (Slim)
MPEDCUS-15-__ (Mobile)

WARRANTY

Craftsmanship: Lifetime
Cushion: 2 Years



COLLECTIVE STORAGE



Locker



Pedestals



Credenzas

With our most extensive storage offering yet, Collective Storage features clean design and flexibility for an organized, functional space that doesn't sacrifice style.

FEATURES

- **Aesthetic:** Clean lines complement any modern workspace.
- **Mobile:** Casters allow for easy moving.
- **Organized:** Pencil trays keep office supplies organized and easily accessible (not included with 30" credenza).
- **Stable:** All units include locking casters. Anti-tipping counterweight included with locker and pedestals.
- **Flexible:** Optional cushion available for any storage unit for impromptu, movable seating.
- **A Safe Space™ Product:** Easy to clean with stowaway spaces for personal belongings.

SPECIFICATIONS

Finishes

- White
WH
- Silver
SI
- Black
BK

Cushion Colors

- Charcoal
CH

Additional cushion colors available, see page 129

Dimensions

Locker:
12" W x 20" D x 24" H

Pedestals:
Slim: 12" W x 20" D x 24" H
Mobile: 15" W x 20" D x 24" H

Credenzas:
30": 30" W x 15" D x 24" H
48": 48" W x 20" D x 27" H

Part Numbers

Locker:
STG-LKR-12-__

Pedestals:
STG-PED-12-___ (Slim)
STG-PED-12-___ (Mobile)

Credenzas:
STG-CRD-30-___ (30")
STG-CRD-48-___ (48")

Cushions:
STG-CUS-12-___ (Locker/Slim Pedestal)
STG-CUS-15-___ (Mobile Pedestal)
STG-CUS-30-___ (30" Credenza)
STG-CUS-48-___ (48" Credenza)

WARRANTY

7 Years



SEATING

HAT Collective offers everything you need to work your way, including our original ergonomic seating solution. Every body is different. Our HAT Collective seating adapts to an individual's natural movement making for a fluid and supportive experience.





ACCESSORIES

Our collection of accessories ensures you get the most out of your workspace. Manage and organize wires, mobilize your keyboard, or mount your CPU. We have everything you need to complete your desk, personalizing your workstation to function for you.



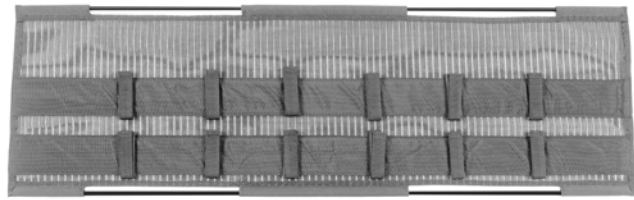

POCKET



Keep cords neat and organized with an easy to install mesh cable management sleeve that is compatible with any base and worksurface. Includes 12 velcro straps that securely lock in your wires.

SPECIFICATIONS

Finishes

-  Grey
-  Black

Standard Pocket

Width: 38"
Depth: 5"
Weight Capacity: Up to 10 lbs.

Part Numbers

CMT-04 (Black)
CMT-06 (Grey)

Mini Pocket

Width: 24"
Depth: 5"
Weight Capacity: Up to 10 lbs.

Part Numbers

CMT-24-04 (Black)
CMT-24-06 (Grey)



Pocket



Mini Pocket



VERTICAL WIRE MANAGEMENT SYSTEM



Exclusive to S-Collection workstations, the vertical's flexible design manages wires on a vertical plane through a BIFMA-required range. The main unit attaches to the leg with magnets, allowing for flexibility of mounting and reconfiguration.

SPECIFICATIONS

Shroud Finishes

-  White
W
-  Silver
S
-  Black
B

Chain Finish

-  Black
B

Height Range: 22" - 48"

Certified: BIFMA

Part Numbers

439900_

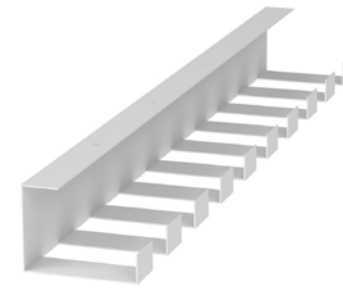

FLEX WIRE MANAGEMENT TRAY



This tray comes in three sizes. Its flexible design and thin steel construction allow for high flexibility in mounting and configuration. Seams along the surface indicate where bending should occur.

SPECIFICATIONS

Finishes

-  White
W
-  Silver
S
-  Black
B

Dimensions

Small: 22.4" W x 2.4" H
Medium: 43.7" W x 2.4" H
Large: 57.5" W x 2.4" H

Part Numbers

990103_ (Small)
990102_ (Medium)
990101_ (Large)



Vertical Wire Management

Pocket

Flex Wire Management Tray

WIRE MANAGEMENT TROUGH

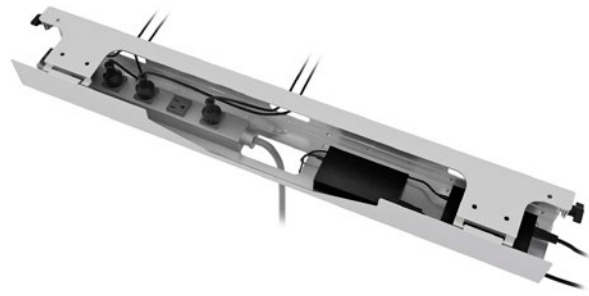

FEATURES

- **Capacity:** Heavy-duty steel construction and large capacity supports multiple wires, cables and a powerstrip.
- **Versatile:** Multiple cable pass-through ports offers versatile cable management.
- **Easy:** Trough hinges open, allowing for easy access and installation.

SPECIFICATIONS

Finishes

■ Silver
SI

Dimensions

30" W x 3" H x 4" D

Part Numbers

WMT-SI

WIRE MANAGEMENT SLEEVE



Captures wires and cables together but allows wires to enter and exit at any desired location without unzipping.

SPECIFICATIONS

Finishes

■ Black
BLK

Dimensions

Length: 42"

Part Numbers

WMS-42

CABLE MANAGEMENT TRAY



Allows cables to lay outside of HAT Power & Data Beam and HAT Benching.

SPECIFICATIONS

Finishes

■ White
WH

■ Silver
SI

■ Black
BK

Dimensions

Depth: 4"
Widths: 36", 48", 60", 72"

Part Numbers

CMT2-_-_-

FOKUS TASK LIGHT



FEATURES

- **Adjustable:** Double arm provides focused ambiance.
- **Touch Control:** Three-way touch dimmer allows users to easily control brightness.
- **Smart:** Light turns off after 15 minutes of detecting no motion, remembers last selected brightness when turned back on.

SPECIFICATIONS

Finishes

■ White
WH

■ Black
BK

Arm Reach: 27.2"

Color Temperature: 3000K

Lumens: 470

Lamp Life: 50,000 Hours

CRI: 90+

Power: 6.6 Watts

Dimmer: Touch Dimmer - 33%, 66%, 100%

Rotation: 180° rotation at light source, 180° rotation on base

Cord Length: 7'

Part Numbers

FOKUS-2-_-



REYA POWER

Meet Reya – our new power family. Reya’s design-forward architecture with soft, curved lines offers a full spectrum of mountable power options for your workstation. Whatever your power needs, big or small, Reya provides power conveniently at your fingertips.



LOW PROFILE USB HUB*

Finishes

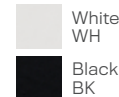

Features

1 USB-A charger port
1 USB-C charger port
Can charge laptop up to 65 Watts (requires 5A-Rated USB-C cable)
Mount: Desk edge/surface mount, under mount, edge mount (desk edge/surface mount: 0.5" - 1.75")

Specifications

Input: DC, 65W max from HAT Base Control Box
Output:
Single Port in Use:
USB-C: QC2.0, QC3.0, PD3.0, PPS, 65W max
USB-A: 5V/2A, 10W max
Both Ports In Use:
USB-C: 20V2.25A max
USB-A: 5V2A max

Dimensions

Product: 2.4" x 2.2" x 1.2"
Cord Length, PWR-AC: 5'
Cord Length, PWR-AC-PS: 39" AC Adapter Cable, 71" Power Cable

Part Numbers

PWR-AC-__ USB Hub, Requires HAT Base
PWR-AC-PS-__ USB Hub, Includes AC Adapter



STANDARD SURFACE POWER MODULE

Finishes

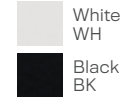

Features

2 power receptacles
1 USB-A charger port
2 USB-C charger ports
Can charge laptop up to 65 Watts (requires 5A-Rated USB-C cable)
Mount: Desk edge, 0.75" - 1.75"
Conforms and tested to UL 962A and UL 1310 standards
Tamper-resistant (TR) AC outlets
Integrated circuit breaker

Specifications

Input: 125VAC, 60Hz, 15A max
Output:
AC Outlets (2): 120VAC, 60HZ, 15A max
Single port use:
USB-A: 5V3A, 9V2.A, 12V1.5, 18W max
USB-C1: 5V/3A, 9V3A, 12V3A, 15V3A, 20V3.25A; PPS (3.3-11V4.05A, 3.3-16V3A, 65W max); PD3.0, APPLE2.4A, DCP1.5A, QC2.0/3.0, AFC
USB-C2: 5V3A, 9V2.22A, 12V1.67A, 20W max
Multi port use:
USB-C1 + USB-C2: USB-C1 max 45W (5V3A, 9V3A, 12V3A, 15V2.67A, 20V2.25A); USB-C2 max 20W (5V3A, 9V2.22A, 12V1.67A)
USB-C1 + USB-A: USB-C1 max 45W (5V3A, 9V3A, 12V3A, 15V2.67A, 20V2.25A); USB-A max 18W (5V3A, 9V2.A, 12V1.5, 18W max)
USB-C2 + USB-A: Both share 15W
USB-C1 + USB-C2 + USB-A: USB-C1 max 45W (5V3A, 9V3A, 12V3A, 15V2.67A, 20V2.25A); USB-C2 & USB-A share 15W

Dimensions

Product: 7.1" x 3.3" x 2.3"
Cord Length: 6'

Part Numbers

PWR-ACC-__ Standard Surface Power Module

Accessory

PWR-UM-CK Under Mount Kit



WIRELESS SURFACE POWER MODULE

Finishes

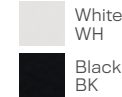

Features

2 power receptacles
1 USB-A charger port
2 USB-C charger ports
Can charge laptop up to 65 Watts (requires 5A-Rated USB-C cable)
Fast wireless charging
Mount: Desk edge, 0.75" - 1.75"
Conforms and tested to UL 962A and UL 1310 standards
Tamper-resistant (TR) AC outlets
Integrated circuit breaker

Specifications

Input: 125VAC, 60Hz, 15A max
Output:
AC Outlets (2): 120VAC, 60HZ, 15A max
Single port use:
USB-A: 5V3A, 9V2.A, 12V1.5, 18W max
USB-C1: 5V/3A, 9V3A, 12V3A, 15V3A, 20V3.25A; PPS (3.3-11V4.05A, 3.3-16V3A, 65W max); PD3.0, APPLE2.4A, DCP1.5A, QC2.0/3.0, AFC
USB-C2: 5V3A, 9V2.22A, 12V1.67A, 20W max
Multi port use:
USB-C1 + USB-C2: USB-C1 max 45W (5V3A, 9V3A, 12V3A, 15V2.67A, 20V2.25A); USB-C2 max 20W (5V3A, 9V2.22A, 12V1.67A);
USB-C1 + USB-A : USB-C1 max 45W (5V3A, 9V3A, 12V3A, 15V2.67A, 20V2.25A); USB-A max 18W (5V3A, 9V2.A, 12V1.5, 18W max)
USB-C2 + USB-A : Both share 15W
USB-C1 + USB-C2 + USB-A : USB-C1 max 45W (5V3A, 9V3A, 12V3A, 15V2.67A, 20V2.25A); USB-C2 & USB-A share 15W;
Wireless Charging: 5W, 7.5W, 10W, 15W (auto detection)

Dimensions

Product: 7.1" x 3.3" x 2.4"
Cord Length: 6'

Part Numbers

PWR-ACC-WRLS-__ Wireless Surface Power Module



POWER STRIP

Finishes

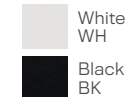

Features

6 power receptacles
Conforms and tested to UL 962A and UL 498 standards
Tamper-resistant (TR) AC outlets
Integrated circuit breaker

Specifications

Input: 125VAC, 60Hz, 15A max
Output:
AC Outlets (6): 120VAC, 60HZ, 15A max

Dimensions

Product: 14.6" x 2.4" x 1.5"
Cord Length: 9'

Part Numbers

PWR-STRP-__ Power Strip



POWER STRIP WITH HARDWIRED STANDARD SURFACE POWER MODULE

Finishes

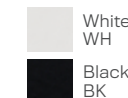

Features

Power Strip: 6 power receptacles
Power Module: 2 power receptacles
1 USB-A charger port
2 USB-C charger ports
Can charge laptop up to 65 Watts (requires 5A-Rated USB-C cable)

Conforms and tested to UL 962A, UL 1310, and UL 498 standards
Tamper-resistant (TR) AC outlets
Integrated circuit breaker

Specifications

Input: 125VAC, 60Hz, 15A max
Output, Power Strip:
AC Outlets (6): 120VAC, 60HZ, 12A max
Output, Surface Mounted Power Module:
AC Outlets (2): 120VAC, 60HZ, 15A max
USB:

Single Port Use
USB-A: 5V3A, 9V2.A, 12V1.5, 18W max
USB-C1: 5V/3A, 9V3A, 12V3A, 15V3A, 20V3.25A; PPS (3.3-11V4.05A, 3.3-16V3A, 65W max); PD3.0, APPLE2.4A, DCP1.5A, QC2.0/3.0, AFC
USB-C2: 5V3A, 9V2.22A, 12V1.67A, 20W max
Multi Port Use
USB-C1 + USB-C2: USB-C1 max 45W (5V3A, 9V3A, 12V3A, 15V2.67A, 20V2.25A); USB-C2 max 20W (5V3A, 9V2.22A, 12V1.67A)
USB-C1 + USB-A: USB-C1 max 45W (5V3A, 9V3A, 12V3A, 15V2.67A, 20V2.25A); USB-A max 18W (5V3A, 9V2.A, 12V1.5, 18W max)
USB-C2 + USB-A: Both share 15W
USB-C1 + USB-C2 + USB-A : USB-C1 max 45W (5V3A, 9V3A, 12V3A, 15V2.67A, 20V2.25A); USB-C2 & USB-A share 15W

Dimensions

Surface Unit: 7.1" x 3.3" x 2.4"
Power Strip: 14.6" x 2.4" x 1.5"
Cord Length:
Input: 9'
Between Units: 3'

Part Numbers

PWR-ACC-STRP-__ Power Strip w/Standard Module
PWR-ACC-WRLS-STRP-__ Power Strip w/Wireless Module



Reya Power Modules can charge a laptop up to 65 Watts (requires 5A-Rated USB-C cable).

CHARGING CAP



Charging cap on top down monitor mount (mount not included)

FEATURES

- **Ports:** Dual USB-A charger ports, single USB-C charger port.
- **Space-Saving:** Snaps onto our single or dual top down monitor mount.

SPECIFICATIONS

Finishes

- White WH
- Silver SI
- Black BK

Input: 100-240VAC, 50/60Hz, 2.0A (Max)
Output: 24VDC, 3A, 72w

Part Numbers

CHG-CAP-1-___ (single mount charging cap)
CHG-CAP-2-___ (dual mount charging cap)
CHG-CAP-E-___ (E2 Dual charging cap)

KEYBOARD TRAY



FEATURES

- **Seamless:** Short track seamlessly integrates with height-adjustable bases.
- **Easy:** Soft touch knob adjusts tilt.
- **Flexible:** Mouse pad can be repositioned to the left or right hand side.

SPECIFICATIONS

Finishes

- Black

Keyboard Tray Size: 27" W x 10" D
Track Length: 11"
Tilt Adjustment: +10/-10 degrees
Swivel: 360 degree

Part Numbers

KT-27

CPU HOLDERS



CPU-HLDR-1

CPU-HLDR-2

FEATURES

- **Space-Saving:** Adjustable CPU holders save space by securing CPU's under the desk.

SPECIFICATIONS

Finishes

- Black BLK

Compatibility: Supports computers 11.8" - 21" H, 3.5" - 8" D

Weight Capacity: Up to 22 lbs.

Mount: Attaches under desk

Part Numbers

CPU-HLDR-1-BLK
CPU-HLDR-2-BLK (Includes 11" Track)

SLIDER



FEATURES

- **Flexible:** Increases the flexibility of monitor positioning.
- **Compatible:** Works with E2 Connex, 7000, and Staxx series monitor arms.

SPECIFICATIONS

Finishes

- Flat White 248
- Silver 124
- Vista Black 104

Adjustment Range: 9" left to right

Part Numbers

8538-___

WINSTON MAT



FEATURES

- **Support:** This durable anti-fatigue mat delivers deep-cushion comfort and supports your feet and joints.

SPECIFICATIONS

Finishes

- Black BLK

Dimensions: 36" W x 24" D x .75" H

Material: Commercial grade, heavy-duty polyurethane.

Part Numbers

WNST-MAT

WORKSTATIONS



	Mid HAT 2-Stage (pp 8-9)	S-Collection SE 2-Leg, 2-Stage (pp 20-21)	Hi HAT 3-Stage (pp 10-11)	S-Collection SX 2-Leg, 3-Stage (pp 22-23)	HAT L Unit 3-Leg (pp 12-13)	S-Collection 3-Leg (pp 24-25)
Height Range	27.25" - 46.75"	27.1" - 45.6"	23.75" - 49"	22.2" - 48.7"	23.75" - 49"	2-Stage: 27.1" - 45.6" 3-Stage: 22.2" - 48.7"
Base Width	S: 24" - 41" L: 42" - 72"	36" - 96"	S: 24" - 41" L: 42" - 72"	36" - 96"	42" - 74"	Varies by SKU
Adjustability	Electric	Electric	Electric	Electric	Electric	Electric
Programmable Handset Included	Yes	Yes	Yes	Yes	Yes	Yes
Speed	1.2" per second	1.5" per second	1.5" per second	1.5" per second	1.5" per second	1.5" per second
Max Weight Capacity	250 lbs.	350 lbs.	250 lbs.	350 lbs.	350 lbs.	525 lbs.
Cable Manager Included	Yes	Optional	Yes	Optional	Yes	Optional
Anti-Collision Safety Function	Yes	Yes	Yes	Yes	Yes	Yes
Certifications/Qualifications	BIFMA, UL 962, GreenGuard, and qualifies for LEED credits	ANSI/BIFMA, UL 962	BIFMA, UL 962, GreenGuard, and qualifies for LEED credits	ANSI/BIFMA, UL 962	BIFMA, UL 962, GreenGuard, and qualifies for LEED credits	ANSI/BIFMA, UL 962
Frame Finishes	White, Silver, Black	White, Silver, Black	White, Silver, Black	White, Silver, Black	White, Silver, Black	White, Silver, Black
Warranty	Motor & Parts: 12 Years Craftsmanship: Lifetime	Motor & Parts: 12 Years Craftsmanship: Lifetime	Motor & Parts: 12 Years Craftsmanship: Lifetime	Motor & Parts: 12 Years Craftsmanship: Lifetime	Motor & Parts: 12 Years Craftsmanship: Lifetime	Motor & Parts: 12 Years Craftsmanship: Lifetime
In-Stock	Yes	No	Yes	No	Yes	No

WORKSTATIONS



	Fielle (pp 30-31)	HAT Benching (pp 14-15)	Elle (pp 32-33)	HAT Group & Conference Table (pp 16-17)	Ellehaven (pp 36-37)	M-Series Nesting (pp 42-43)
Height Range	21.1" - 47.6"	27.25" - 46.75"	Enshrined: 27" - 46.7" Top Mounted: 28" - 47.7" (w/ 1" worksurface)	27.25" - 46.75"	28" - 47.7" (w/ 1" worksurface)	28.6" - 45.1"
Base Width	60", 72"	48", 60", 72"	60", 72"	42" - 74"	84", 96", 108", 120"	28"
Adjustability	Electric	Electric	Electric	Electric	Electric	Constant Force Spring
Programmable Handset Included	Optional	Yes	Yes	Yes	Yes	No
Speed	1.5" per second	1.2" per second	1.5" per second	1.2" per second	1.5" per second	-
Max Weight Capacity	350 lbs.	300 lbs.	400 lbs.	350 lbs.	450 lbs.	35 lbs.
Cable Manager Included	Integrated	Yes	Optional	Yes	Optional	No
Anti-Collision Safety Function	Yes	Yes	Yes	Yes	Yes	No
Certifications/Qualifications	-	BIFMA, GreenGuard, and qualifies for LEED credits	-	BIFMA, GreenGuard, and qualifies for LEED credits	-	-
Frame Finishes	White, Silver, Black	White, Silver, Black	White, Silver, Black	Black	White, Silver, Black	White, Silver, Black
Warranty	Motor & Parts: 12 Years Craftsmanship: Lifetime	Motor & Parts: 12 Years Craftsmanship: Lifetime	Motor & Parts: 12 Years Craftsmanship: Lifetime	Motor & Parts: 12 Years Craftsmanship: Lifetime	Motor & Parts: 12 Years Craftsmanship: Lifetime	Motor & Parts: 12 Years Craftsmanship: Lifetime
In-Stock	No	Yes	No	No	No	No

WORKSTATIONS



	Winston Workstation (pp 54-55)	Winston-E (pp 56-57)
Height Adjustment Mechanism	Pneumatic	Electric
Weight Capacity	Varies by SKU	30 lbs.
Height Adjustment	17.1"	18.4"
Finishes	Flat White, Silver, Vista Black	Grey Duotone
Dual Monitor Option	Yes	Yes
Multi-Monitor (3+)	Yes	Yes
Mount Configurations	Freestanding	Freestanding
Warranty	5 Years	5 Years
In-Stock	Yes	Yes

MONITOR ARMS

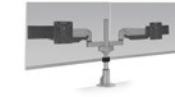

	E2 (pp 80-81)	E2 Connex (pp 82-85)	7000 (pp 86-87)	7000 Crossbar (pp 88-89)	7500 (pp 90-91)	Staxx (pp 92-97)
Screen Size	Any size within weight range	Varies by SKU	Any size within weight range	Up to 27"	Up to 43"	Up to 30"
Weight Capacity	2.2 - 20 lbs.	Varies by SKU	3 - 28 lbs.	6 - 14 lbs. per monitor	2 - 40 lbs.	Varies by SKU
Height Adjustment	13.3"	Varies by SKU	16"	15.5"	18"	Varies by SKU
Extension Range	23.7"	Varies by SKU	23.4"	17.8"	27"	Varies by SKU
Finishes	Flat White, Silver, Vista Black	Flat White, Silver, Vista Black	Flat White, Silver, Vista Black	Flat White, Silver, Vista Black	Flat White, Silver, Vista Black	Flat White, Silver, Vista Black
Dual Monitor Option	Yes	Yes	Yes	Yes	Yes	Yes
Multi-Monitor (3+)	No	Yes	No	No	No	Yes
Mount Configurations	C-Clamp, Grommet	C-Clamp, Grommet	C-Clamp, Grommet	C-Clamp, Grommet	C-Clamp, Grommet, Thru. Wall, Reverse Wall, Side Bolt	C-Clamp, Grommet
Warranty	10 Years	10 Years	10 Years	10 Years	10 Years	10 Years
In-Stock	Yes	No	Yes	Yes	Yes	Yes

METAL	LAMINATES & WOOD	PET & FABRIC
<p>Bases</p> <p>In-Stock:</p> <ul style="list-style-type: none"> White WH Silver SI Black BK <p>Standard:</p> <ul style="list-style-type: none"> Steel Antique DM Steel Matte HC Charcoal CH Mocha 40 Clear 42 <p>Power & Data Beam</p> <ul style="list-style-type: none"> White WH Silver SI Black BK <p>Storage</p> <ul style="list-style-type: none"> White WH Silver SI Black BK <p>Desktop Converters</p> <ul style="list-style-type: none"> Flat White 248 Silver 124 Vista Black 104 Grey Duotone 270 White WHT Black BLK <p>Monitor Arms</p> <ul style="list-style-type: none"> Flat White 248 Silver 124 Vista Black 104 <p>Monitor Arms (E5)</p> <ul style="list-style-type: none"> White WHT Silver SLV Black BLK Polished Aluminum PWH 	<p>Laminates</p> <p>In-Stock & Standard:</p> <ul style="list-style-type: none"> Designer White DW Manitoba Maple MM Fawn Cypress FC Pinnacle Walnut PW <p>Wood (Fiellø)</p> <p>Standard:</p> <ul style="list-style-type: none"> Oak WO Walnut WW <p>Laminates (Fiellø)</p> <p>Standard:</p> <ul style="list-style-type: none"> Linen Feather Platinum Charcoal Black 	<p>PET</p> <p>In-Stock:</p> <ul style="list-style-type: none"> Ash ASH Slate SLATE Charcoal* CHARCOAL Iced Grey* IG <p>Standard:</p> <ul style="list-style-type: none"> Ash ASH Slate SLATE Charcoal CHARCOAL Iced Grey IG Cobalt COBALT Oat OAT Pear PEAR Sandstone SANDSTONE <p>Recycled PET (Aura & Fiellø)</p> <p>Standard:</p> <ul style="list-style-type: none"> Night FNI Slate FSL Pebble FPE Black FBL Oatmeal FOA Latte FLA
		<p>Fabric</p> <p>Elements Line (Grade 1) Standard:</p> <ul style="list-style-type: none"> Euro F102 Poppy F104 Sodalite F108 Arundel F112 Stately F113 Sapphire F114 Steel F120 Iron F121 Basalt F122 Jet F123 <p>Fusion Line (Grade 2) Standard:</p> <ul style="list-style-type: none"> Barley F210 Rinse F214 Capri F218 Aster F219 Beyond F220 Stucco F221 Aluminum F222 Dove F223 Gull F230 Pewter F231

ACRYLIC & WHITE BOARD	STORAGE CUSHIONS	SEATING	IN-STOCK
<p>Standard:</p> <ul style="list-style-type: none"> Clear Acrylic CLA Frosted Acrylic FRA White Board WB 	<p>In-Stock:</p> <ul style="list-style-type: none"> Charcoal 15-13 <p>Standard:</p> <ul style="list-style-type: none"> Sapphire 15-03 Poppy 15-04 Mica 15-07 Salmon 15-08 Garnet 15-11 Meadow 15-15 Mauve 15-16 Taupe 15-17 Fern 15-18 Teal 15-19 Black 15-21 Sodalite 15-41 Blue 15-44 Iron 15-48 Seafoam 15-49 Orange 15-75 Rust 15-102 Yellow 15-104 Khaki 15-106 Brown 15-109 Lilac 15-110 Frost Green 15-118 Denim 15-153 Mustard 15-155 Blue Green 15-161 Fez 15-164 Midnight 15-167 Sapphire 15-173 Purple 15-184 	<p>Frame:</p> <ul style="list-style-type: none"> White W Black B <p>Mesh:</p> <ul style="list-style-type: none"> Cloud M3H Smoke M2H Raven M1H <p>Seat Upholstery:</p> <ul style="list-style-type: none"> Alloy ALLOY Iron IRON Jet JET <p>Base:</p> <ul style="list-style-type: none"> Polished Aluminum SIPB Black Nylon S1BB 	<p>Bases</p> <ul style="list-style-type: none"> White WH Silver SI Black BK <p>Power & Data Beam</p> <ul style="list-style-type: none"> White WH Silver SI Black BK <p>Storage (HAT Pedestals)</p> <ul style="list-style-type: none"> White WH Silver SI Black BK <p>Desktop Converters</p> <ul style="list-style-type: none"> Silver 124 Vista Black 104 Grey Duotone 270 White WHT Black BLK <p>Monitor Arms</p> <ul style="list-style-type: none"> Silver 124 Vista Black 104
			<p>Laminates</p> <ul style="list-style-type: none"> Designer White DW Manitoba Maple MM Fawn Cypress FC Pinnacle Walnut PW <p>Dividers (PET)</p> <ul style="list-style-type: none"> Ash ASH Slate SLATE Charcoal* CHARCOAL Iced Grey* IG <p>Pedestal Cushion</p> <ul style="list-style-type: none"> Charcoal 15-13
			<p>Seating</p> <p>Frame:</p> <ul style="list-style-type: none"> Black B <p>Mesh:</p> <ul style="list-style-type: none"> Raven M1H <p>Seat Upholstery:</p> <ul style="list-style-type: none"> Jet JET Black Nylon S1BB <p>Base:</p> <ul style="list-style-type: none"> Black Nylon S1BB



HAT
COLLECTIVE™
HUMAN ACTIVE TECHNOLOGY

HAT Collective
Global Headquarters
100 Kuebler Road
Easton, PA 18040

800 524 2744
hatcollective.com

