



HAT
COLLECTIVE™
HUMAN ACTIVE TECHNOLOGY



WORKSTATIONS



Fiello Workstation, E2 Connex Monitor Arm, Power Module, Collective Storage with Cushion & Custom Laminate, Iku Task Chair

WORK YOUR WAY

WORKSTATIONS

HAT Collective workstations epitomize innovative design and functionality, helping to easily create an active, productive office environment. Sleek aesthetic and quality construction come together to provide a beautiful, healthy, and personalized work experience. Our standard product line offers unmistakable European flare and our in-stock bases are ideal for quick installations.



IN-STOCK

MID HAT

NEXT-LEVEL ADJUSTABILITY.

This two-legged, height-adjustable base is the ultimate in workspace transformation. The exclusive Folding HAT frame design allows for easy assembly, quickly fitting into any corner or rectangular station. The quiet electric motor system is eco-friendly and makes movement simple.

HAT bases are reliably stocked in three colors. This clever design is expandable, with no fixed-width cross bar to stand in your way.



Mid HAT Workstation, E2 Connex Monitor Arm, Reya Power, HAT Power & Data Beam, Fabric Divider, Mobile Pedestal Slim with Cushion, Iku Task Chair

Mid HAT Workstation, 7000 Monitor Arm, Senko Task Light, Power Module, CPU Holder, Mobile Pedestal with Cushion, Iku Task Chair



Mid HAT Workstation

Height Range	27.25" - 46.75"
Width Options	S: 24" - 41" L: 42" - 72"
Weight Capacity	250 lbs. including top
Frame Finish	White, Silver, Black



Scan for more product info, resources, and configurator

● In-stock product ships within 3 business days.



Hi HAT Workstation, Envoy Monitor Arm, Power Module, Senko Task Light, HAT Power & Data Beam, PET Divider, Mobile Pedestal Slim, Iku Task Chair

IN-STOCK

HI HAT

FREEDOM TO MOVE.

Create an active work environment with a base that offers maximum height capability. With Hi HAT, users have increased access to movement, which allows for a healthier, happier, and more productive work life.

This sturdy three-stage electric base uses an easy-to-assemble, folding frame design. The width of the base is expandable and includes a reliable, programmable handset, dual sync motors, and the assurance of an anti-collision safety monitor.

Height Range	23.75" - 49"
Width Options	S: 24" - 41" L: 42" - 72"
Weight Capacity	250 lbs. including top
Frame Finish	White, Silver, Black



Scan for more product info, resources, and configurator



Hi HAT Workstation

Hi HAT Workstation, Staxx Monitor Arm, Power Module, Acrylic Divider, HAT Power & Data Beam, Mobile Pedestal with Cushion



IN-STOCK

HAT L UNIT 3-LEG

FIT IN ANYWHERE.

This three-legged unit brings height adjustability to the furthest corners of your office. Whether you need a 90-degree or 120-degree angle, the L-Unit makes movement possible.

Sophisticated electric adjustments can be made with the press of a button on this three-stage base. The reliable sit-stand frame provides the flexibility needed for a healthy, productive day at work.

HAT L Unit Workstation, 7000 Monitor Arm, Senko Task Light, Power Module, CPU Holder, Winston Mat



HAT L Unit Workstation, 7500 Monitor Arm, Power Module, Senko Task Light, Modesty Panel, Mesa Slide Divider, PET Divider, Mobile Pedestal with Cushion, HAT Power & Data Beam, Iku Task Chair



HAT L Unit Workstation

Height Range	23.75" - 49"
Width Options	42" - 74"
Weight Capacity	350 lbs. including top
Frame Finish	White, Silver, Black



Scan for more product info, resources, and configurator



HAT Benching Workstation, 7000 Monitor Arm, Snap On Charging Cap, Mesa PET Wrap Divider, Mobile Pedestal with Cushion

IN-STOCK

HAT BENCHING

MAXIMIZE FLOOR SPACE.

This dynamic benching unit provides flexibility and affordability in one sleek solution. Replace traditional workstations with all-in-one benching, allowing employees to maintain movement by alternating between sitting and standing positions throughout the day. HAT benching quickly creates a productive, comfortable, and healthy office environment.

The expandable HAT Benching design is available in various widths and can be used with PET, fabric, acrylic, or white board dividers. The unit incorporates a convenient built-in power and data beam, along with position programming and dual sync motors for safe, easy height adjustments.

HAT Benching Workstation, E2 Monitor Arm, Snap On Charging Cap, PET Divider, Mobile Pedestal Slim with Cushion



Height Range	27.25" - 46.75"
Width Options	48", 60", 72"
Weight Capacity	300 lbs. including top
Frame Finish	White, Silver, Black



Scan for more product info, resources, and configurator

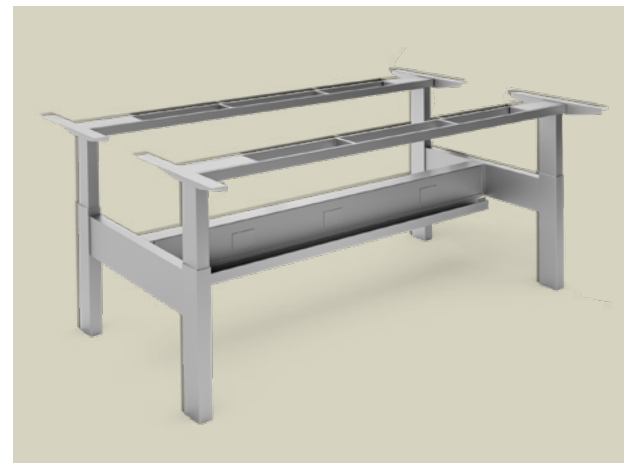

HAT Benching Workstation

HAT GROUP & CONFERENCE TABLE

MOVE TOGETHER.

Team meetings may be long, but they don't have to be painful. This four-legged electric conference base means even shared workspaces can transition from sit to stand.

Improve the productivity of your brainstorming sessions with this impressively large height-adjustable electric base. Expandable widths and multiple worksurface options ensure the right fit for your space.



HAT Group & Conference Table

Height Range	27.25" - 46.75"
Width Options	72" - 120"
Weight Capacity	350 lbs. including top
Frame Finish	White, Silver, Black



Scan for more product info, resources, and configurator



HAT Group & Conference Table



HAT Power & Data Beam, PET Divider, Hi HAT Workstation, 7000 Crossbar Monitor Arm, Senko Task Light, Power Module, Mobile Pedestal with Cushion, Iku Task Chair

IN-STOCK

HAT POWER & DATA BEAM

POWER, CONSOLIDATED.

Keep your workspace organized and powered up with this convenient plug-in track. Whether you need power or data or voice to do your job, this accessory allows for a clean custom set-up.

The lightweight Power & Data Beam keeps wires off the floor and nestled neatly under your worksurface. Its built-in BYRNE 8 TRAC power system includes a four-circuit, eight-wire electrical system. The beam also allows for integrated divider installation.

HAT Power & Data Beam, Mid HAT Workstation, Mobile Pedestal with Cushion



Beam Length	36", 48", 60", 72"
Height	23"
Frame Finish	White, Silver, Black



Scan for more product info, resources, and configurator



HAT Power & Data Beam with Cable Management Tray

S-COLLECTION SE 2-LEG, 2-STAGE

SIMPLY ELEGANT,
WONDERFULLY FUNCTIONAL.

This 2 Leg, 2-Stage desking solution exemplifies the Danish design principles of simplicity and functionality. This electric, height-adjustable table offers a slightly smaller height range than the 3-Stage, but with equal weight capacity and visual configurations.

A wide range of color combinations, finishes, and surface shapes make the 2-Stage a highly customizable option. This electric sit-to-stand table comes in a 2-leg configuration with a long list of optional features.

S-Collection SE 2-Stage Workstation, Envoy Monitor Arm, Power Module, Aura Divider, Ivy Power & Data Beam



S-Collection SE 2-Stage Workstation, E2 Connex Monitor Arm, Senko Task Light, Reya Power Module, Aura Divider, Ivy Power & Data Beam, Collective Pedestal with Cushion, Iku Task Chair



S-Collection SE 2-Leg, 2-Stage Workstation

Height Range	27.1" - 45.6"
Width Options	36" - 96"
Weight Capacity	350 lbs. including top
Frame Finish	White, Silver, Black



Scan for more product info, resources, and configurator



S-Collection SX 3-Stage Workstation, E2 Monitor Arm, Power Module, Aura Divider, Ivy Power & Data Beam, Collective Storage Credenza with Cushion, Iku Task Chair

S-COLLECTION SX 2-LEG, 3-STAGE

THE PINNACLE OF DESIGN,
QUALITY, AND VERSATILITY.

The 2-Leg, 3-Stage offers S-Collection's largest height range. This electric sit-to-stand table comes in a 2-leg configuration, with all of the bells and whistles we could fit onto one worksurface.

Elegance meets powerful functionality in this 2-leg, 3-stage height adjustable desking solution. Choose from a wide range of laminates, finishes, and optional tech features to create your ideal workspace.

S-Collection SX 3-Stage Workstation, Staxx Monitor Arm, Power Module, HAT Power & Data Beam with Cable Management Tray, Fabric Divider, Collective Storage Credenza with Cushion, Iku Task Chair



Height Range	22.2" - 48.7"
Width Options	36" - 96"
Weight Capacity	350 lbs. including top
Frame Finish	White, Silver, Black



Scan for more product info, resources, and configurator



S-Collection SX 3-Stage Workstation

S-COLLECTION 3-LEG

WORKSPACE SATISFACTION IS JUST AROUND THE CORNER.

Office planning has never been easier. Our 3-Leg S-Collection offers beautifully comfortable, flexible, and ergonomic solutions for your work environment.

Our 3-leg electric desks are available in both 2 and 3-stage height adjustability, along with a multitude of opportunities for customization. No matter what your requirements, S-Collection can be configured to satisfy.



S-Collection 3-Leg Workstation

Height Range	2-Stage: 27.1" - 45.6" 3-Stage: 22.2" - 48.7"
Weight Capacity	525 lbs. including top
Frame Finish	White, Silver, Black



Scan for more product info,
resources, and configurator



S-Collection 3-Leg Workstation, Power Module, Pocket Cable Management



S-COLLECTION PANEL MOUNTED

INTEGRATION THAT WORKS, WHEREVER YOU NEED IT.

Our panel integration solution is designed to create a seamless union between the S-Collection and panel systems. Brackets introduce a safe locking solution into the system by staying free from pinch points and avoiding interference with existing furniture.

Panel Mount integration is available for new systems as well as pre-installed units. Working with existing panels presents a cost-efficient option and reduces waste for a more environmentally friendly approach. Integration also creates space below the surface by allowing for the use of smaller feet. The recessed frame design is perfect for adding a storage pedestal or CPU.

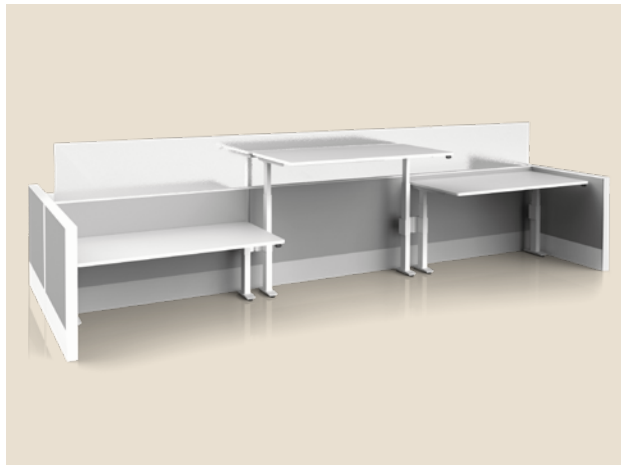

Height Range	2-Stage: 27.1" - 45.6" 3-Stage: 22.2" - 48.7"
Weight Capacity	350 lbs. including top
Frame Finish	White, Silver, Black



Scan for more product info, resources, and configurator

S-Collection Panel Mounted Workstation

S-COLLECTION WALL MOUNTED

SMART, SLEEK, AND SPACE-SAVING.

This iteration makes S-Collection a permanent fixture in your place of work. Secure your new electric, height-adjustable table to the wall and transform dead space into a useful touchdown worksurface.

Wall Mounted takes all of the coveted features of our high-end electric desking solution and transforms it into a mounted worksurface. Choose your shape, finishes, and optional features and enjoy the benefits of height adjustability.



S-Collection Wall Mounted Workstation

S-Collection Wall Mounted Workstation



S-Collection Wall Mounted Workstation

Height Range	2-Stage: 30.1" - 48.6" 3-Stage: 25.2" - 51.7" (with 1.125"-thick worksurface and placed 3" above the floor)
Width Options	36" - 48" 49" - 72"
Weight Capacity	250 lbs. including top
Frame Finish	White, Silver, Black



Scan for more product info,
resources, and configurator



Fiellø Workstation with Full Ribbon Panels, 7500 Monitor Arm, Power Module, Iku Task Chair

FIELLØ®

NORDIC MINIMALISM.

Meet the new Fiellø. Sleek and sophisticated, Fiellø's Danish roots inspire the simplistic elegance of its fabrication. Fiellø's minimalist approach expresses itself in clean lines, cylindrical legs, and low-profile feet that all speak to the intent of the architectural experience. Adding visual interest and warmth to Fiellø includes our curved ribbon panels, either crafted out of natural wood or felted PET. Both options complete the Scandinavian experience Fiellø aims to fulfill.

Product Design Consultant **Gensler**

Height Range	21.1" - 47.6"
Worksurface Size	60" x 30", 72" x 30"
Weight Capacity	350 lbs. including top
Frame Finish	White, Silver, Black



Scan for more product info, resources, and configurator



Fiellø Workstation with Full Ribbon Panels

Fiellø Workstation with Ribbon Panel, E2 Connex Monitor Arm, Snap On Charging Cap, Senko Task Light, Ivy Power & Data Beam



ELLE

THE PERFECT COMPANION FOR A HEALTHY WORKDAY.

This elegant, Parsons-style table offers unmatched stability compared to other 4-leg, height-adjustable models.

Elle is available in four different surface-mounting conditions, for a tailored design and fit. The optional cable tray makes power management easy, while the adjustable crossbar allows for simple reconfiguration.



Elle Workstation with Enshrined Worksurface, Envoy Dual, Power Module, Senko Task Light, Aura Divider, Ivy Power & Data Beam, Collective Storage Locker, Ellehaven, Iku Task Chair

Elle Workstation with Top Mounted Worksurface, Envoy Dual Monitor Arm, Power Module, Senko Task Light



Elle Workstation

Height Range	Enshrined Surface: 27" – 46.7" Top Mounted Surface: 28" – 47.7"
Width Options	60", 72"
Weight Capacity	400 lbs. including top
Frame Finish	White, Silver, Black



Scan for more product info, resources, and configurator



Ellehaven Group & Conference Table

Height Range	28" - 47.7"
Width Options	84", 96", 108", 120"
Depth Options	36", 42", 48"
Weight Capacity	450 lbs. including top
Frame Finish	White, Silver, Black



Scan for more product info, resources, and configurator



Ellehaven Group & Conference Table

ELLEHAVEN

SLEEK DESIGN AND THE FREEDOM OF CHOICE.

Designed and manufactured in Denmark, Ellehaven's sleek and sophisticated design is only the beginning. Ellehaven's electric lift can be powered by cable or battery. This built-in flexibility makes this height-adjustable table suitable for any layout, while maintaining your environment's aesthetics. An optional wire management tray holds batteries and wires in place for added organization.

Ellehaven Group & Conference Table, Iku Task Chair



M-SERIES FREESTANDING

DESIGNED WITH EASE
AND VERSATILITY IN MIND.

Whether as a stand-alone workstation, in a pod layout, or as a touch-down surface, the height-adjustable M-Series flexes to work for you. This customizable table is available in three models and a variety of specifications, which means it fits wherever you need it. Choose your ideal worksurface shape to get the base and top combo that best suits your needs.



M-Series Freestanding Table with Casters, Iku Task Chair

M-Series Freestanding Table



M-Series Freestanding Table

Height Range	27.6" - 44.1"
Worksurface Shapes	Rectangular
Weight Capacity	15 - 105 lbs. (Column available in Ultralight, Light, Medium, and Heavy)
Frame Finish	White, Silver, Black



Scan for more product info, resources, and configurator



M-SERIES NESTING

THESE INDIVIDUAL NESTING DESKS WORK HARD, MAKING YOUR JOB EASIER.

M-Series Nesting combines collaborative, mobile desking with the benefits of sit-to-stand. The unique flower petal design enables quick room reconfiguration, from training rows to huddle groups, and nesting saves space.

Nesting desktops can even be ordered with dry-erase white board laminate, allowing users to jot notes during a meeting, flip the top to 90 degrees, and present on their own personal white board. Your training room has now become an ergonomic, innovative, and flexible resource for the entire team.

M-Series Nesting Table

Height Range	27.6" - 44.1"
Worksurface Shape	Petal
Weight Capacity	0 - 25 lbs.
Frame Finish	White, Silver, Black



Scan for more product info, resources, and configurator



M-Series Nesting Table

M-Series Nesting Table



M-SERIES TRIPOD & QUAD

MAKING TEAMWORK A SNAP.

Team up with an M-Series Tripod or Quad combo for comfortable, productive break-out meetings.

These multi-seater desks adapt the best of M-Series for team sessions. Meetings shouldn't inhibit your ability to work ergonomically.



M-Series Quad Table

M-Series Tripod Table



M-Series Tripod Table

Height Range	27.6" - 44.1" (including 1" thick surface)
Worksurface Size	36" - 40" x 18" - 24"
Weight Capacity	15 - 105 lbs. (Column available in Ultralight, Light, Medium)
Frame Finish	White, Silver, Black



Scan for more product info, resources, and configurator



M-Series Wall Mount Workstation

M-SERIES WALL

FOR A PRODUCTIVE PAUSE, USE WALL MOUNT.

This wall-mounted desking solution takes the beauty of the M-Series and adds a tilting mechanism.

Perfect for small spaces, hospitals, and lobbies, the Wall Mount delivers an ergonomic, height-adjustable touchdown area. Wall Mount is also available with added tilt for easy adjustability in a small mounting footprint.

Height Range	29.4" - 45.9" (including 1" thick surface and placed 3" above the floor)
Max Worksurface Width	20" - 48"
Max Worksurface Depth	18", 24"
Weight Capacity	15 - 60 lbs. (Column available in Ultralight and Light)
Frame Finish	White, Silver, Black



Scan for more product info, resources, and configurator



M-Series Wall Mount Workstation

M-Series Wall Mount Workstation



IN-STOCK

WINSTON WORKSTATION[®]

GIVE YOUR DESK A BOOST.

This workstation instantly converts any desk into a sit stand workspace, boosting health and productivity. Winston is available in single, dual, triple, and quadruple monitor support.

The Winston's worksurface easily reserves room for a keyboard, mouse, and storage tray. Retrofit your existing desk into a healthy workspace with three easy mounting options. Winston Compact is ideal for users with limited space who want to take advantage of a healthy sit-stand workstation.



Winston Workstation

Height Range	17.1"
Worksurface Size	30" W x 23" D
Weight Capacity	Single: 7 - 20 lbs. Dual: 10 - 26 lbs. Triple: 15 - 36 lbs. Quad: 24 - 40 lbs.
Monitor Support	Up to four monitors
Finish	Flat White, Silver, Vista Black



Scan for more product info, resources, and configurator





Winston-E

IN-STOCK

WINSTON-E®

UPGRADE YOUR WORKSPACE.

Winston-E is a responsive powered riser that takes the sit-stand conversation to a whole new level. The next-generation retrofit worksurface with monitor arms is engineered for freedom of movement and is available in a single, dual, or triple monitor configuration.

Focal depth adjustment and independent movement keeps monitor at a comfortable, ergonomic level.



Winston-E

Height Range	18.4"
Worksurface Size	30" W x 22" D
Weight Capacity	40 lbs.
Monitor Support	Up to three monitors
Finish	Grey Duotone



Scan for more product info, resources, and configurator

DIVIDERS

CREATE VISUAL & ACOUSTICAL PRIVACY IN ANY OPEN ENVIRONMENT.



MESA WRAP



MESA SLIDE



MESA ACRYLIC



FABRIC DIVIDER

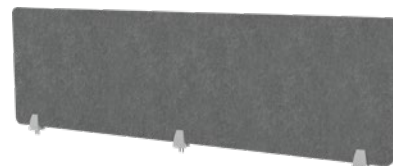

PET DIVIDER



WHITE BOARD DIVIDER



ACRYLIC MODESTY PANEL

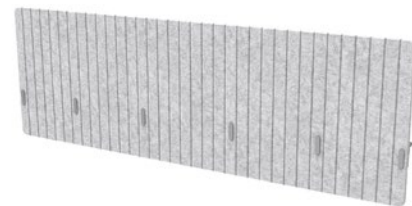

AURA



Scan for more product info, resources, and configurator



Aura Divider, S-Collection 2-Stage Workstation, Envoy Monitor Arm, Ivy Power & Data Beam



360 WORKSPACE™

A "360 workspace" supports how people work and leads to greater productivity and work satisfaction by considering technology, ergonomics, how people work, and the environment. 360 workplace design empowers workers through a fully functional workspace – a 360 workspace that limits distraction and provides the ergonomic support, flexibility, movement, and technology integrations workers need to do their best thinking and creating.

HAT Collective can help you put the pieces together and create the perfect 360 Workplace. Please get in touch with us for more information or guidance on 360 Workspaces.



1
START WITH THE BEST
HEIGHT ADJUSTABLE DESK

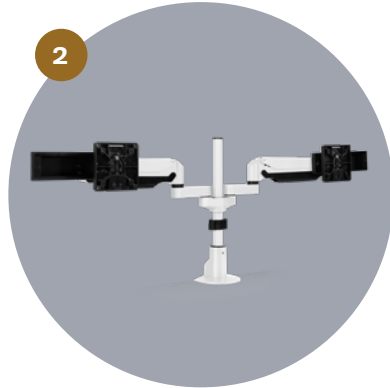

2
DETERMINE YOUR MONITOR NEEDS
AND ADD ADJUSTABLE MONITOR ARMS



3
ENSURE YOU HAVE A CONVENIENT
POWER SUPPLY FOR YOUR WORKSPACE



4
FIND THE BEST
ERGONOMIC DESK CHAIR



5
CHOOSE LIGHTING
FOR A HEALTHY WORKSPACE



6
MANAGE AND CONTROL
YOUR ACCESSORIES



COMPARISON CHART



	Mid HAT 2-Stage (pp 6-7)	S-Collection SE 2-Leg, 2-Stage (pp 18-19)	Hi HAT 3-Stage (pp 8-9)	S-Collection SX 2-Leg, 3-Stage (pp 20-21)	HAT L Unit 3-Leg (pp 10-11)	S-Collection 3-Leg (pp 22-23)
Height Range	27.25" - 46.75"	27.1" - 45.6"	23.75" - 49"	22.2" - 48.7"	23.75" - 49"	2-Stage: 27.1" - 45.6" 3-Stage: 22.2" - 48.7"
Base Width	S: 24" - 41" L: 42" - 72"	36" - 96"	S: 24" - 41" L: 42" - 72"	36" - 96"	42" - 74"	Varies
Adjustability	Electric	Electric	Electric	Electric	Electric	Electric
Programmable Handset Included	Yes	Yes	Yes	Yes	Yes	Yes
Speed	1.2" per second	1.5" per second	1.5" per second	1.5" per second	1.5" per second	1.5" per second
Max Weight Capacity	250 lbs.	350 lbs.	250 lbs.	350 lbs.	350 lbs.	525 lbs.
Cable Manager Included	Yes	Optional	Yes	Optional	Yes	Optional
Anti-Collision Safety Function	Yes	Yes	Yes	Yes	Yes	Yes
Certifications/Qualifications	BIFMA, UL 962, GreenGuard, and qualifies for LEED credits	ANSI/BIFMA, UL 962	BIFMA, UL 962, GreenGuard, and qualifies for LEED credits	ANSI/BIFMA, UL 962	BIFMA, UL 962, GreenGuard, and qualifies for LEED credits	ANSI/BIFMA, UL 962
Frame Finishes	White, Silver, Black	White, Silver, Black	White, Silver, Black	White, Silver, Black	White, Silver, Black	White, Silver, Black
Warranty	Motor & Parts: 12 Years Craftsmanship: Lifetime	Motor & Parts: 12 Years Craftsmanship: Lifetime	Motor & Parts: 12 Years Craftsmanship: Lifetime	Motor & Parts: 12 Years Craftsmanship: Lifetime	Motor & Parts: 12 Years Craftsmanship: Lifetime	Motor & Parts: 12 Years Craftsmanship: Lifetime
In-Stock	Yes	No	Yes	No	Yes	No



	Fiello (pp 28-29)	Elle (pp 30-31)	HAT Benching (pp 12-13)	S-Collection Panel Mount (pp 24-25)	M-Series Tripod & Quad (pp 38-39)
Height Range	21.1" - 47.6"	Enshrined: 27" - 46.7" Top Mounted: 28" - 47.7" (w/ 1" worksurface)	27.25" - 46.75"	2-Stage: 27.1" - 45.6" 3-Stage: 22.2" - 48.7"	27.6" - 44.1" (w/ 1" thick surface)
Base Width	60", 72"	60", 72"	48", 60", 72"	-	-
Adjustability	Electric	Electric	Electric	Electric	Constant Force Spring
Programmable Handset Included	Optional	Yes	Yes	Yes	No
Speed	1.5" per second	1.5" per second	1.2" per second	1.5" per second	-
Max Weight Capacity	350 lbs.	400 lbs.	300 lbs.	350 lbs.	15 - 105 lbs. (Column available in Ultralight, Light, Medium)
Cable Manager Included	Integrated	Optional	Yes	Yes	Integrated
Anti-Collision Safety Function	Yes	Yes	Yes	Yes	No
Certifications/Qualifications	-	-	BIFMA, GreenGuard, and qualifies for LEED credits	ANSI/BIFMA, UL 962	-
Frame Finishes	White, Silver, Black	White, Silver, Black	White, Silver, Black	White, Silver, Black	White, Silver, Black
Warranty	Motor & Parts: 12 Years Craftsmanship: Lifetime	Motor & Parts: 12 Years Craftsmanship: Lifetime	Motor & Parts: 12 Years Craftsmanship: Lifetime	Motor & Parts: 12 Years Craftsmanship: Lifetime	Motor & Parts: 12 Years Craftsmanship: Lifetime
In-Stock	No	No	Yes	No	No

COMPARISON CHART CONTINUED



	M-Series Freestanding (pp 34-35)	M-Series Nesting (pp 36-37)	M-Series Wall Mount (pp 40-41)	S-Collection Wall Mount (pp 26-27)	HAT Group & Conference Table (pp 14-15)	Ellehaven Group & Conference Table (pp 32-33)
Height Range	27.6" - 44.1"	28.6" - 45.1"	29.4" - 45.9" <small>(w/ 1" thick surface and placed 3" above the floor)</small>	2-Stage: 30.1" - 48.6" 3-Stage: 25.2" - 51.7" <small>(w/ 1.125" thick surface and placed 3" above the floor)</small>	27.25" - 46.75"	28" - 47.7" <small>(w/ 1" thick worksurface)</small>
Base Width	-	28"	-	36" - 48" 49" - 72"	72" - 120"	84", 96", 108", 120"
Adjustability	Constant Force Spring	Constant Force Spring	Constant Force Spring	Electric	Electric	Electric
Programmable Handset Included	No	No	No	Yes	Yes	Yes
Speed	-	-	-	1.5" per second	1.2" per second	1.5" per second
Max Weight Capacity	15 - 105 lbs. <small>(Column available in Ultralight, Light, Medium, and Heavy)</small>	0 - 25 lbs.	15 - 60 lbs. <small>(Column available in Ultralight and Light)</small>	250 lbs.	350 lbs.	450 lbs.
Cable Manager Included	No	No	No	Yes	Yes	Optional
Anti-Collision Safety Function	No	No	No	Yes	Yes	Yes
Certifications/Qualifications	-	-	-	-	BIFMA, GreenGuard, and qualifies for LEED credits	-
Frame Finishes	White, Silver, Black	White, Silver, Black	White, Silver, Black	White, Silver, Black	Black	White, Silver, Black
Warranty	Motor & Parts: 12 Years Craftsmanship: Lifetime	Motor & Parts: 12 Years Craftsmanship: Lifetime	Motor & Parts: 12 Years Craftsmanship: Lifetime	Motor & Parts: 12 Years Craftsmanship: Lifetime	Motor & Parts: 12 Years Craftsmanship: Lifetime	Motor & Parts: 12 Years Craftsmanship: Lifetime
In-Stock	No	Yes	No	No	No	No



	Winston Workstation (pp 42-43)	Winston-E (pp 44-45)
Adjustability	Pneumatic	Electric
Weight Capacity	Varies	40 lbs.
Height Adjustment	17.1"	18.4"
Dual Monitor Option	Yes	Yes
Multi-Monitor (3+)	Yes	Yes
Mount Configurations	Freestanding	Freestanding
Finishes	Flat White, Silver, Vista Black	Grey Duotone
Warranty	5 Years	5 Years
In-Stock	Yes	Yes

STATEMENT OF LINE

BASES

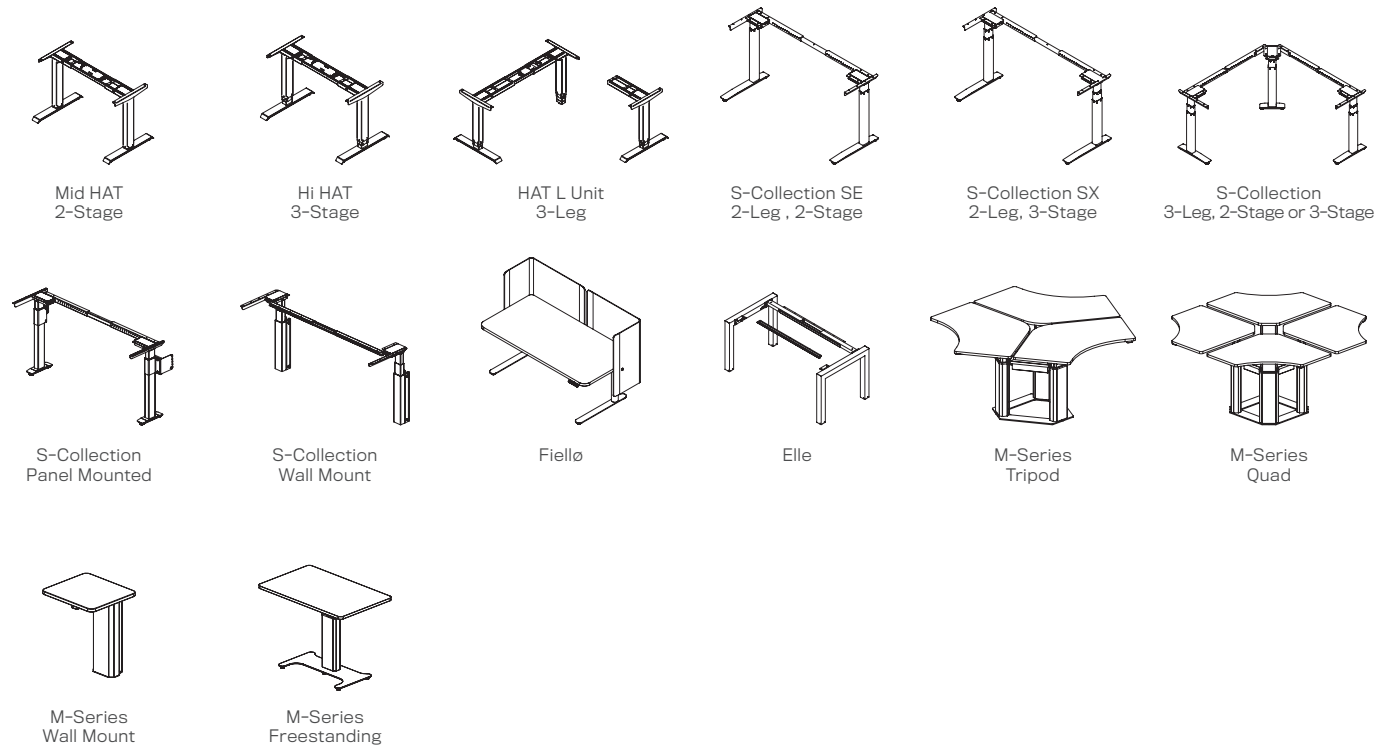

DESKTOP CONVERTERS

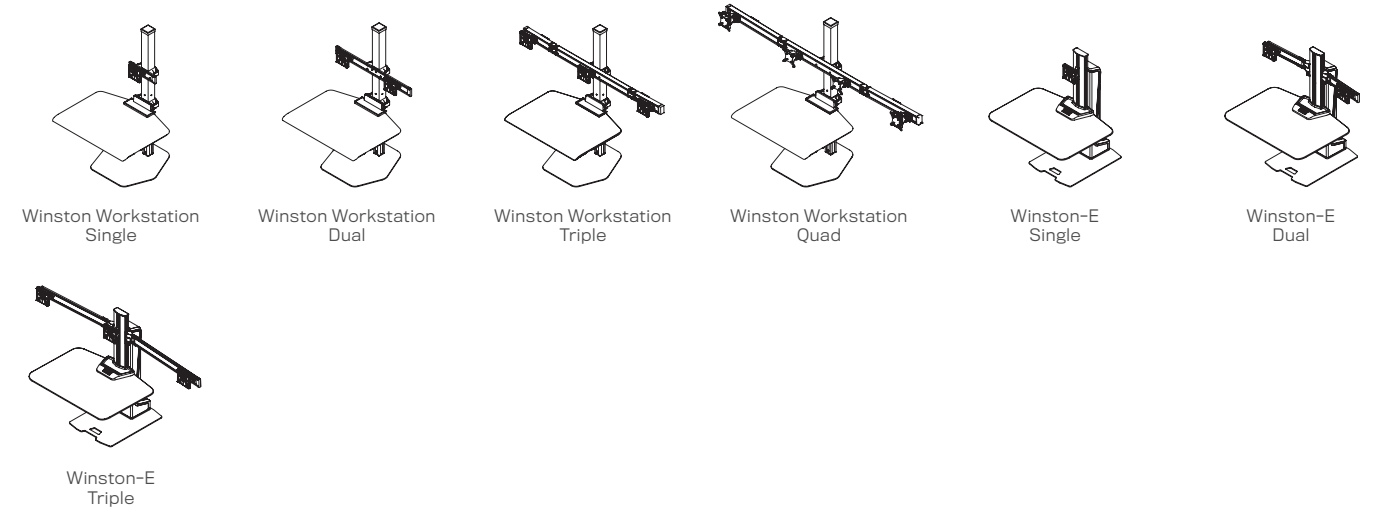

POWER & DATA BEAM

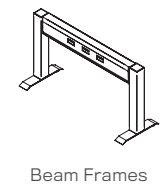

BENCHING

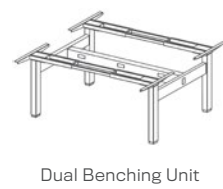

GROUP & CONFERENCE

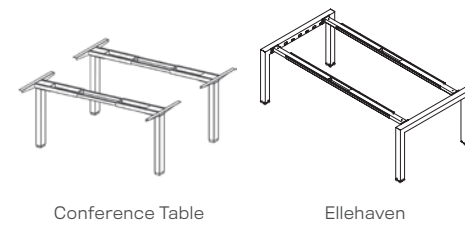

DIVIDERS

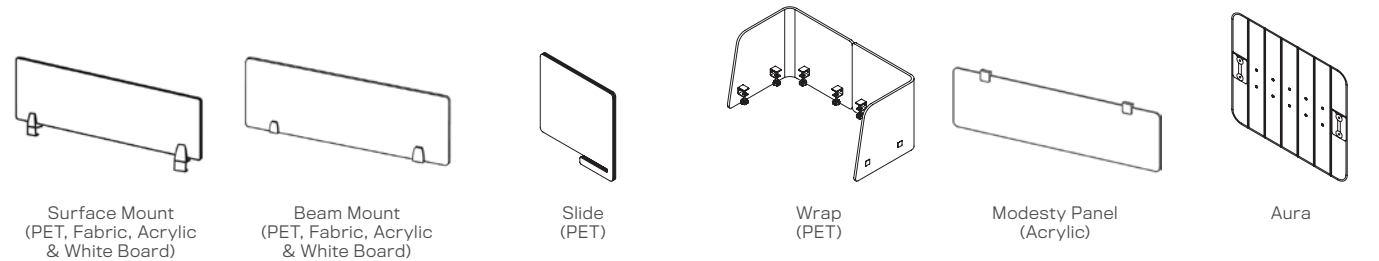

WORKSURFACES

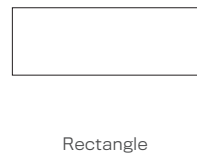

MOBILE



MATERIALS

METAL

LAMINATES & WOOD

PET & FABRIC

Bases

In-Stock:

- White WH
- Silver SI
- Black BK

Standard:

- White W
- Silver S
- Black B
- Steel Antique DM
- Steel Matte HC
- Charcoal CH
- Mocha 40
- Clear 42

Power & Data Beam

In-Stock:

- White WH
- Silver SI
- Black BK

Desktop Converters

In-Stock:

- Silver 124
- Vista Black 104
- Grey Duotone 270

Standard:

- Flat White 248

Laminates

In-Stock:

- Designer White DW
- Fawn Cypress FC

Standard:

- Designer White DW
- Manitoba Maple MM
- Fawn Cypress FC
- Pinnacle Walnut PW

Laminates (Fiello)

Standard:

- Linen
- Feather
- Platinum
- Charcoal
- Black

Wood (Fiello)

Standard:

- Oak WO
- Walnut WW

PET

In-Stock:

- Ash ASH
- Slate SLATE
- Charcoal* CHARCOAL
- Iced Grey* IG

Standard:

- Ash ASH
- Slate SLATE
- Charcoal CHARCOAL
- Iced Grey IG
- Cobalt COBALT
- Oat OAT
- Pear PEAR
- Sandstone SANDSTONE

Recycled PET (Aura & Fiello)

Standard:

- Night FNI
- Slate FSL
- Pebble FPE
- Black FBL
- Oatmeal FOA
- Latte FLA

Fabric

Elements Line (Grade 1)

Standard:

- Gaia F101
- Euro F102
- Mikan F103
- Poppy F104
- Sodalite F108
- Arundel F112
- Stately F113
- Sapphire F114
- Steel F120
- Iron F121
- Basalt F122
- Jet F123

Fusion Line (Grade 2)

Standard:

- Barley F210
- Sable F211
- Java F212
- Lemongrass F213
- Rinse F214
- Radiant F215
- Tyrian F216
- Hyacinth F217
- Capri F218
- Aster F219
- Beyond F220
- Stucco F221
- Aluminum F222
- Dove F223
- Links F224
- Atoll F225
- Maize F226
- Papaya F227
- Macintosh F228
- Berry F229
- Gull F230
- Pewter F231

ACRYLIC & WHITE BOARD

Standard:

- Clear Acrylic CLA
- Frosted Acrylic FRA
- White Board WB

IN-STOCK

Bases

- White WH
- Silver SI
- Black BK

Power & Data Beam

- White WH
- Silver SI
- Black BK

Desktop Converters

- Silver 124
- Vista Black 104
- Grey Duotone 270

Laminates

- Designer White DW
- Fawn Cypress FC

Dividers (PET)

- Ash ASH
- Slate SLATE
- Charcoal* CHARCOAL
- Iced Grey* IG



Scan to view materials library.



HAT
COLLECTIVE™
HUMAN ACTIVE TECHNOLOGY

HAT Collective
Global Headquarters
100 Kuebler Road
Easton, PA 18040

800 524 2744
hatcollective.com

