



WALL TRACK WORKSTATION w/COMBO ARM

MONITOR ARMS



HAT
DESIGN WORKS™
HUMAN ACTIVE TECHNOLOGY

ULTIMATE FUNCTIONALITY.

Caregivers can work sitting or standing with everything they need with our flexible wall track workstation. Easily reposition your screen or keyboard up and down, side-to-side to keep eye contact with your patients. The monitor and keyboard are easy to reposition and store, improving patient care by making caregivers' jobs easier and more comfortable.



Flexible positioning allows the keyboard tray and arm to fold flat against wall when not in use



Cables are routed through track and hidden behind cable channel



Optional CPU Holders available, can be mounted to wall track or directly to wall

FEATURES

- **Comfortable:** Monitor and keyboard tray move together making it quick and easy to reposition.
- **Ergonomic:** Keyboard tray tilts up and down to protect wrists from injury.
- **Space-Saving:** The arm and keyboard tray can be folded flat against wall when not in use.
- **Organized:** Cables stay hidden behind cable channel keeping spaces clean and clutter-free.
- **Cleanability:** Easy-to-clean surfaces allows for thorough and efficient cleaning.
- **Compatible:** VESA-monitor compatible – 75 & 100mm VESA adapter included.

SPECIFICATIONS

Finishes

- Flat White
248
- Vista Black
104

Dimensions

- Track Length: 31"
- Monitor Height Adjustment: 18"
- Monitor Weight Capacity: 6 - 23 lbs.
- Screen Size: Up to 27"
- Keyboard Tray Size: 19" L x 8" W (excludes mouse tray)

Part Number

HM-WT002-___

Accessories

- 8335-SM-___ Small CPU Holder
- 8335-MD-___ Medium CPU Holder
- 8335-LG-___ Large CPU Holder

WARRANTY

10 Years

CAPABILITIES

Full Up

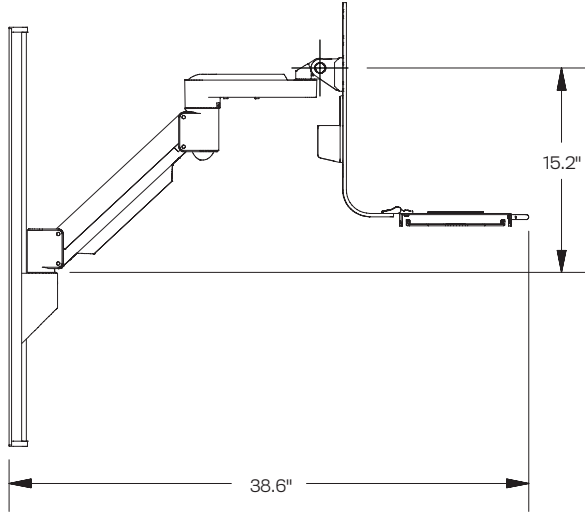

Full Down

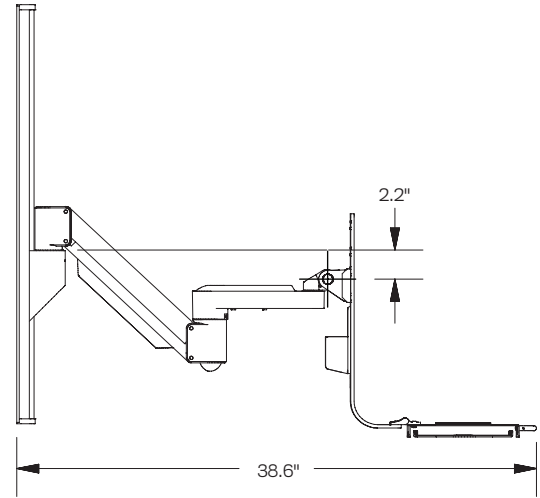

Fully Extended

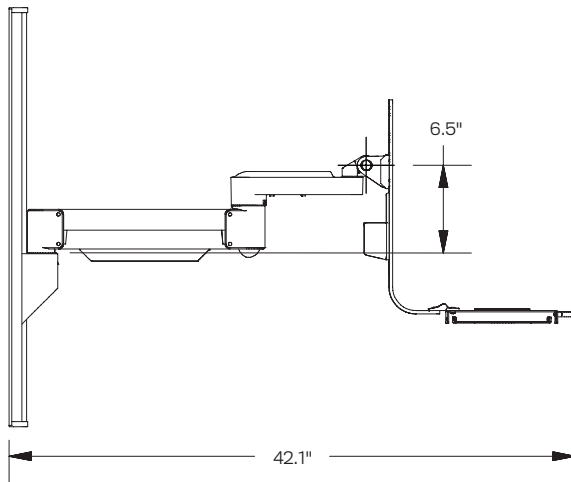

Folded Against Wall

