



SEPTEMBER 2024



HAT
COLLECTIVE™
HUMAN ACTIVE TECHNOLOGY

WORK YOUR WAY.

Our product collection empowers you to choose the way you work. An individualized workspace ultimately leads to increased job satisfaction, improved health and well-being, and higher levels of engagement and productivity. Whether in the office or at home, sitting or standing, together or at a distance, our flexible, sophisticated range of workplace solutions lets you work your way.



TABLE OF CONTENTS

INTRODUCTION

Warranty.....	4
Terms & Conditions.....	5
Freight.....	8
Lead Times.....	10

WORKSTATIONS

Workstations.....	16
Bases.....	19
Mobile.....	42
Power & Data Beam.....	56
Benching.....	60
Group & Conference.....	52, 62
Worksurfaces.....	64
Desktop Converters.....	66
Dividers & Modesty Panels.....	72

MONITOR ARMS	86
---------------------------	----

STORAGE	98
----------------------	----

SEATING	104
----------------------	-----

ACCESSORIES

Lighting.....	107
Wire Management.....	108
Power & Docking.....	109
CPU Holders.....	112
Mounts & Adapters.....	112
Keyboard Trays.....	115

WARRANTY

Seller warrants that its products will be free from defects in material and workmanship when the title passes to the buyer. Seller will repair (only pre-approved labor and service costs are covered under this warranty) or replace (or issue a pro-rated credit if a similar product is no longer available), at its discretion, any defective product without charge (shipping charges excluded).

Seller may require proof of purchase before performing any repairs or replacing any products during the warranty period. Except as specifically set forth above, Seller makes no warranties, express or implied and specifically disclaims any warranty of merchantability or fitness for a particular purpose. Repair or replacement of the product ordered from Seller shall be buyer's exclusive remedy.

Seller will not be responsible for incidental or consequential damages.

THIS WARRANTY DOES NOT APPLY TO:

- Damage caused by a carrier.
- Labor charges.
- Normal wear and tear.*
- Defects caused by failure to follow instructions related to the product's installation or intended use.
- COM or other third party materials applied to the products.
- Products subjected to improper use and conditions.
- User modification of, or attachments to the product, including application of your own materials
- Damage resulting from misuse, negligence, accident or alteration.

* Normal use consists of a 5 day, 40 hour work week.

This warranty shall be effective for the applicable time period starting from date of purchase as shown on your original receipt or other proof of purchase. The warranty covers the original purchaser of the product.

PRODUCTS:

- Bases, Benching: craftsmanship for the life of the product. Electrical and mechanical components are warranted for 12 years (effective 1/1/24).
- Power and Data Beam: craftsmanship for the life of the product. Electrical and mechanical components are warranted for 7 years.
- Pedestals are warranted for their lifetime
- Pedestal Cushions are warranted for 2 years.
- Worksurfaces & Dividers are warranted for 5 years. (Worksurface & Divider exclusions include: normal wear and tear, which are to be expected over the course of ownership; damage caused by abuse, misuse, neglect, vandalism, accident, disaster, improper storage, chemical damage, water or fire; damage caused by the carrier in-transit, which will be handled as claims against the carrier; modifications or attachments to the product that are not approved by the Company or use of a product in combination with products or equipment not appropriate for that product; products that were not installed, used or maintained in accordance with product instructions and warnings; causes external to a product such as use of improper cleaning supplies or environmental factors; products which have been modified or altered, repaired or refurbished by someone other than the company.)
- Winston Series: 5 years
- One Touch: 10 years unit/parts, 2 years motor
- Movel: 3 years
- Seating: Parts and components: 10 years, Mesh: 5 years

ACCESSORIES:

- Keyboard Trays: 1 year
- Monitor Arms: 10 years
- Power Modules: 5 years
- CPU Holders: 5 years
- Lighting: 2 years
- Docking Station: 1 year

TERMS & CONDITIONS

The following terms and conditions shall apply to all orders by buyer ("Buyer" or "you") for goods and services purchased from Human Active Technology (individually the "Seller" or "Us", and, together with Buyer, the "parties"). By accepting delivery, Buyer agrees to be bound by and accepts these terms and conditions. These terms and conditions supersede the terms and conditions of or attached to the Buyer's purchase order or any similar document submitted by Buyer (a "Purchase Order"), meaning any provision of the Buyer's Purchase Order or attachment thereto which conflicts with these terms and conditions shall be ineffective and these terms and conditions shall govern each Purchase Order unless the Seller shall subsequently agree otherwise in writing.

1. RESERVATION OF RIGHTS

Seller reserves the right to change at any time without notice these terms and conditions.

2. PAYMENT TERMS

a. CREDIT – Credit may be extended to Buyer at Seller's sole discretion. Credit approval is required for all orders on open account. All products, parts and services sold to Buyer on open account are due 'Net 30 Days' from date of invoice, unless otherwise agreed to in writing at the time of sale. A service charge at the then-current prevailing rate is assessed on delinquent balances. Seller reserves the right to change this rate or the 'Net 30 Days' payment due date from time to time. Service charges will be assessed monthly. The current rate is 1.5% per month (18% annually) or the maximum rate allowed by law, whichever is less. Buyer is responsible for cancellation costs and attorney's fees associated with collection of monies owed to Seller by Buyer. Buyer shall notify Seller in writing of errors contained in invoices within 30 days of issuance. Invoices are deemed correct 30 days following issuance. Credit accounts past due will be placed on hold— pending orders will not be shipped and work-in-process for pending orders will be stopped until account is made current by Buyer.

b. DEPOSIT FOR LARGE ORDERS – For orders from new customers of \$20,000 or more, standard terms are: 1/2 deposit with the Purchase Order and 1/2 payment prior to shipment. For orders from established customers of \$50,000 or more, standard terms are: 1/2 deposit with the Purchase Order and 1/2 payment Net 30 Days.

3. CURRENCY

All prices quoted and monies due are in U.S. dollars. For non-U.S. customers, payment may be made by certified check, wire transfer or VISA, MasterCard or American Express.

4. DELIVERY & FREIGHT

a. U.S. SHIPMENTS – Unless otherwise negotiated, standard freight terms for order shipments within the 48 contiguous states of the United States are prepay and add to final invoice. Seller reserves the right to reasonably charge the buyer for all non-standard delivery requirements which may include but are not limited to:

- Consolidation and delivery on the same truck
- Expedited or air freight
- Special shipping or packaging methods
- Liftgates/forklift
- Delivery outside of normal hours
- Inside delivery
- Redelivery, notification, etc.
- Improper refusal of product
- Detention charges
- Street unloads
- Redirection of product
- Storage past acknowledged ship date

(All products in the catalog will receive ship dates respective of their product category and can be found on the following page: 10.)

i. Title passes to Buyer at the dock of the shipping origin. Choice of carrier is at Seller's discretion, unless specified by Buyer's Purchase Order. Freight charges are added to Buyer's invoice unless Buyer's Purchase Order specifies carrier routing, notes "freight collect," and includes applicable carrier account numbers and/or billing information.

ii. For Alaska – freight is prepaid to Port of Seattle, Washington. For Hawaii, freight is prepaid to Port of Oakland, California.

iii. Customer arranged pick up (will-call) is available with timely and reasonable coordination. Once confirmed, Buyer will have three (3) business days from notification to pick up the order. If the order is not picked up within this time frame, storage charges may apply.

iv. All requests for carrier-guaranteed delivery times shall be considered and will include an additional fee, if accepted. This additional fee will be the maximum liability to the Seller. If the carrier misses the guaranteed delivery time, a refund will be issued to customer.

b. NON-U.S. SHIPMENTS – Unless otherwise negotiated and accepted by the Seller in writing, shipments outside of the U.S. are shipped Freight On Board (FOB) Origin or Shipping Origin. Title passes to Buyer at the dock of Shipping Origin regardless of method of shipment. Transportation costs will be added to invoice unless Buyer's Purchase Order specifies carrier routing, notes "freight collect" and includes applicable carrier account numbers and/or billing information. Unless otherwise negotiated, Buyer is responsible for arranging customs clearance and for filing and paying all applicable duties and taxes outside of the United States.

c. DAMAGE – Seller is not responsible for damage that occurred in transit or during storage. Before accepting a shipment from the carrier, Buyer (and/or its designated receiver) is to carefully review the packing list and inspect the quantity and condition of the items. For any external damage, Buyer should document all damage on the Bill of Lading and request a carrier inspection of the product.

d. CONCEALED DAMAGE – Buyer must report concealed damage to the carrier and Seller, in writing, within 48 hours of receipt. In the event of damage, Buyer shall accept the order and contact Seller for issue resolution. Seller agrees to take all reasonable measures to assist Buyer in resolving claims for loss or damage.

e. EARLY SHIPMENTS – Estimated ship dates are sent with order acknowledgements. Seller may ship up to 5 days early, unless requested otherwise on Buyer's Purchase Order.

f. REPACKING CHARGES – Any Buyer requests to change shipment methods or destinations stated on Purchase Order, or any requests from Buyer for special packaging not stated on Purchase Order may result in repacking charges if requests require Seller to repack order.

5. TAXES AND DUTIES

Buyer shall be responsible for all taxes and duties which result from the transfer of title, sale or delivery of the goods and services purchased hereunder. Taxes may not be applied if a valid and correct tax exemption certificate is furnished to Seller prior to shipment.

6. CANCELLATIONS

Purchase Orders may not be changed or canceled, in whole or in part, without prior written consent of Seller. Changes or revisions must be clearly indicated on the new Purchase Order and may affect delivery dates. Expenses incurred because of changes will be charged to the Buyer as customer. In the event of cancellations, the customer will be liable for reasonable cancellation charges established by Seller. Charges may be incurred by Buyer for the entire amount of the order. Orders for customized products, custom finishes or applying Customer's Own Material (COM) may not be canceled. All such custom orders are final and non-refundable.

TERMS & CONDITIONS

(CONTINUED)

7. RETURNS AND CLAIM POLICY

a. RESPONSIBILITY. It is Buyer's responsibility to examine goods upon receipt and to notify Seller with any concerns. Any claims against Seller for apparent defects, errors or shortages must be made by the Buyer within 48 hours after any receipt date. Failure by the Buyer to make any claim against Seller within 48 hours shall constitute acceptance of the goods and waive any apparent defects, errors or shortages.

b. DEFECTIVE ITEMS – Defective items may be returned within limits of the Warranty.

c. CUSTOM-CONFIGURED ITEMS – Non-defective Custom-configured Items are not returnable.

d. RETURNS

Authorized merchandise returns must be approved prior to the arrival of any goods at our dock. Unauthorized returns will not be accepted by Seller. All returns must be labeled with a valid Return Authorization (R/A) number on the outside of packaging. Shipments without R/A numbers will be rejected. R/A numbers may be obtained by calling Seller. Products must be returned to Seller within 30 days of receipt. Returns are subject to up to a 25% restocking fee plus return freight charges. Product must be returned in original cartons in "as new" condition.

e. INSTALLATION

The unboxing and installation of product shall constitute acceptance of the goods and deem the items as "non-returnable."

8. BLANKET ORDERS

Blanket Orders include any order by Buyer to be received in multiple shipments ("releases").

•Buyer must accept all releases within 6 months of Purchase Order receipt, unless agreed by Seller otherwise in writing. Units not requested to be shipped by Buyer within 6 months of Purchase Order receipt will be shipped and invoiced to Buyer immediately following the 6 month deadline. Cancellation and order change fees apply as specified in sections 6a and 6b.

9. WARRANTY

Seller warrants that its products will be free from defects in material and workmanship when the title passes to the Buyer. Seller will repair (only pre-approved labor and service costs are covered under this warranty) or replace (or issue a pro-rated credit if a similar product is no longer available) at its discretion any defective product without charge (shipping charges excluded).

Seller may require proof of purchase before performing any repairs or replacing any products during the warranty period. Except as specifically set forth above, Seller makes no warranties, express or implied, and specifically disclaims any warranty of merchantability or fitness for a particular purpose. Repair or replacement of the product ordered from Seller shall be Buyer's exclusive remedy. Seller will not be responsible for incidental or consequential damages.

THIS WARRANTY DOES NOT APPLY TO:

- Damage caused by a carrier.
- Buyer's labor charges.
- Normal use, wear and tear.*
- Defects caused by failure to follow instructions related to the product's installation or intended use.
- Products subjected to improper use and conditions.
- User modification of, or attachments to the product, including application of your own materials (i.e., COM) or a third party's materials.
- Damage resulting from misuse, negligence, accident or alteration.

*Normal use consists of a 5 day, 40 hour work week.

This warranty shall be effective for the applicable time period starting from date of purchase as shown on your original receipt or other proof of purchase. The warranty covers the original purchaser of the product.

Individual product warranty time periods can be found on the Seller's websites.

10. INSTALLATION

Seller does not take responsibility for Buyer's installation of Seller's products. Buyer must supply own installation or acquire installation services from a third party.

11. ONLINE AUCTIONS

Buyer agrees that product purchased from Seller will not be sold at online auction for less than Seller's suggested retail price, unless clearly marked as "Used" in both auction subject line and descriptive text. Buyer is obligated to inform prospective bidders that Seller's warranties are voided by sale at online auction and product purchased at online auction may not for any reason be returned to Seller for repair, credit or exchange. Seller reserves the right to refuse to sell to any Buyer discovered to be in violation of these terms and conditions.

12. RESALE

Subject to Section 11, on any resale of purchased items the Buyer will contractually limit its buyer's rights and remedies against both Buyer and Seller to the same extent as Buyer's rights and remedies covered in Warranty and Returns and Claim Policy above.

13. PERMITS & COMPLIANCE

Seller is not responsible for obtaining any permits, inspections or licenses required for installation or operation of the goods or services. Seller makes no promise or representation that the goods or services will conform to any federal, state, local, foreign or other laws, ordinances, regulations, codes or standards.

14. LIMITED LIABILITY

The entire liability of Seller to Buyer for any cause whatsoever, regardless of the form of action, whether in contract, tort or otherwise, shall be limited to the direct damages proven or an amount equal to the purchase price of the products or services, whichever is less. In no event shall Seller be liable for any indirect, special reliance, incidental or consequential damages (including lost profits or savings) sustained or incurred in connection with the product. This paragraph shall survive failure of any exclusive remedy.

15. NON-WAIVER

Any failure on Seller's part to insist upon the strict performance of any term or condition set forth herein shall not be deemed a waiver of any of Seller's rights or remedies hereunder, nor of its right to insist upon the strict performance of the same or of any other term of this document in the future. No waiver of any condition of this document shall be valid unless in writing and signed by an authorized representative of Seller.

16. PREVAILING LAW

The parties hereto hereby agree that these terms and conditions (and all Purchase Orders) shall be governed by and construed in accordance with, for all purposes, the laws of the Commonwealth of Pennsylvania, without reference to its rules concerning conflicts of laws, and further agree that the Pennsylvania State courts or the federal court for the Eastern District of Pennsylvania shall have exclusive jurisdiction to hear

TERMS & CONDITIONS

(CONTINUED)

and determine any suit instituted under these terms and conditions (and all Purchase Orders). Each party expressly submits in advance to such jurisdiction in any action or proceeding commenced by the other, and agrees that service of such summons and complaint, or other process or papers, may be made in accordance with the physical Notice provisions hereof concerning certified mail, return receipt requested.

17. NOTICE

The parties may give notice to each other by certified mail, return receipt requested or overnight courier, according to the addresses set forth in the Purchase Order. Ordinary course email notice may be given concerning details of or changes to any given Purchase Order, provided the sender has received electronic confirmation of

FREIGHT

All pricing includes free freight, except for orders under \$2,000 Net. Monitor arms do not incur a freight charge regardless of order value. Any exceptions are noted in this document.

Orders below \$2,000 Net will incur a freight charged based on the information below.

- There is a \$20 minimum freight charge for orders under \$2,000 net, excluding monitor arm and wall mount only orders.

- All orders requiring a residential delivery will be charged a \$50 handling fee

Height Adjustable Bases, Desktop Converters (Winston, One-Touch), Accessories

- For order value less than \$2,000 net, 12% of net

Storage

- For order value less than \$2,000 net, 12% of net with a \$100 minimum Not available to ship via Parcel

Seating

- For order value less than \$2,000 net: \$55 per unit

Worksurfaces, when shipped with bases

- For order value less than \$2,000 net, for worksurfaces of up to 60" x 30", \$89 per worksurface and base combination. Any worksurface larger than 60" x 30" will need to be shipped via LTL and cost will be greater.

The following products are excluded from free freight over \$2,000 net:

- Elle: 1 - 4 qty: \$500, 5+ qty: 12% of net
- Ellehaven: 1 - 4 qty: \$500, 5+ qty: 12% of net
- M Series: 1 - 4 qty: \$500, 5+ qty: 12% of net
- Fiello: 5+ qty: 12% of net

The products below require a freight quote, contact customerservice@team-hat.com or 800-524-2744:

- Orders for worksurfaces that do not include a base
- Special Order/Custom Product

- Alaska: freight is prepaid to Port of Seattle.
- Hawaii: freight is prepaid to Port of Oakland

DELIVERY

Seller reserves the right to reasonably charge the buyer for all non-standard delivery requirements which may include but are not limited to:

- Consolidation and delivery on the same truck
- Expedited or air freight
- Special shipping or packaging methods
- Liftgates/forklift
- Delivery outside of normal hours
- Inside delivery
- Redelivery, notification, etc.
- Improper refusal of product
- Detention charges
- Street unloads
- Redirection of product
- Storage past acknowledged ship date

WILL CALL

Bay Area orders require will call. Freight surcharge of 5% of net applied if shipping required within the Bay Area.

Will Call orders will have a confirmed pick up date. Customers will have three (3) business days from notification to pick up their order. If the order is not picked up within this time frame, storage charges may apply.

TAXES AND DUTIES

Buyer shall be responsible for all taxes and duties which result from the transfer of title or sale or delivery of the Goods & Services purchased hereunder. Taxes may not be applied if a valid and correct tax exemption certificate is furnished to Seller prior to shipment.

CANCELLATIONS

Purchase Orders may not be changed or canceled, in whole or in part, without prior written consent of Seller. Changes or revisions must be clearly indicated on the new Purchase Order and may affect delivery dates. Expenses incurred because of changes will be charged to the Buyer as customer. In the event of cancellations, the customer will be liable for reasonable cancellation charges established by Seller. Charges may be incurred by Buyer for the entire amount of the order. Orders for customized products, custom finishes or applying Customer's Own Material (COM) may not be canceled. All such custom orders are final and non-refundable.

SHIPMENT DAMAGE CLAIMS

Seller is not responsible for damage that occurred in transit or during storage. Before accepting a shipment from the carrier Buyer (and/or their designated receiver) is to carefully review the packing list and inspect the quantity and condition of the items. For any external damage, Buyer should document all damage on the Bill of Lading and request a carrier inspection of the product. Buyer must report concealed damage to the Carrier and Seller in writing, within 48 hours of delivery.

ROUTING

Standard courier shipments are made via common carrier, unless otherwise specified by customer. Special routing requests made by the customer may result in additional charges to the purchaser. All LTL/full-trailer shipments are dock-to-dock.

Shipments are not guaranteed. Should you require guaranteed service please contact Customer Service. We will work to arrange a specific delivery timetable with the carrier, charges may apply.

	LTL: Over \$2,000 NET	LTL: Under \$2,000 NET	Parcel: Over \$2,000 NET	Parcel: Under \$2,000 NET
MONITOR ARMS	Free Freight	Free Freight	Free Freight	Free Freight
BASES	Free Freight	12% of net	Free Freight	12% of net
WORKSURFACES AND BASE COMBO <small>*WORKSURFACES UP TO 60" X 30" 2-LEG BASE ONLY</small>	Free Freight	\$89 per unit	Free Freight	\$89 per unit
DESKTOP CONVERTERS	Free Freight	12% of net	Free Freight	12% of net
ACCESSORIES	Free Freight	12% of net	Free Freight	12% of net
SEATING	Free Freight	\$55 per unit	Free Freight	\$55 per unit
STORAGE	Free Freight	12% of net, \$100 minimum	Not available	Not available
WORKSURFACES <small>*STANDARD FINISHES AND SIZES</small>	Call for quote	Call for quote	Call for quote	Call for quote
ELLE ELLEHAVEN FIELLO M SERIES	1 - 4 qty: \$500 5+ qty: 12% of net	1 - 4 qty: \$500 5+ qty: 12% of net	1 - 4 qty: \$500 5+ qty: 12% of net	1 - 4 qty: \$500 5+ qty: 12% of net
CARTS	7% of net	7% of net	7% of net	7% of net
WALL TRACKS	Free Freight	Free Freight	Free Freight	Free Freight
SPECIAL ORDER CUSTOM	Call for quote	Call for quote	Call for quote	Call for quote

WORKSTATION LEAD TIMES

ALL LEAD TIMES REFLECT BUSINESS DAYS

PRODUCT CATEGORY	MODELS	IN-STOCK FINISH LEAD TIME	STANDARD FINISH LEAD TIME
Bases	Mid HAT	3 Days	8-12 Weeks
	Mid HAT with C-Foot	-	8-12 Weeks
	Hi HAT	3 Days	8-12 Weeks
	Hi HAT with C-Foot	-	8-12 Weeks
	L Unit	3 Days	8-12 Weeks
	S-Collection Frame Only	-	4-6 Weeks
	M-Series Frame Only	-	4-6 Weeks
	Elle Frame Only	-	6-8 Weeks
Power & Data Beam	Beam Frame	3 Days	-
	Posts	3 Days	-
	Duplex Receptacle	3 Days	-
	Power Pole	3 Days	-
	Power Trac	3 Days	-
	Power Feed	3 Days	-
Benching	Dual Benching Unit	3 Days	-
Group & Conference	Conference Table	3 Days	-
	Ellehaven Frame Only	-	6-8 Weeks
Mobile	M-Nesting Frame Only		4-6 Weeks
Worksurfaces	Rectangular: 30" x 48", 30" x 60", 30" x 72"	3 Days*	10-15 Days
	Mid HAT, Hi HAT, L Unit, HAT Benching, S-Collection Worksurfaces	-	10-15 Days
	M-Series Worksurfaces	-	4-6 Weeks
	Elle Worksurfaces	-	4-6 Weeks
	Ellehaven Worksurfaces	-	4-6 Weeks

* 1-24 units will ship in 3 business days from receipt of PO,
25-249 units will ship in 10 - 15 business days from receipt of PO,
250+ call for lead time

WORKSTATION LEAD TIMES

ALL LEAD TIMES REFLECT BUSINESS DAYS

PRODUCT CATEGORY	MODELS	IN-STOCK FINISH LEAD TIME	STANDARD FINISH LEAD TIME
Dividers	PET (Surface/Beam Mounted)	-	10-20 Days*
	Fabric Fold (Surface/Beam Mounted)	-	10-20 Days*
	Acrylic (Surface/Beam Mounted)	-	20 Days*
	White Board (Surface/Beam Mounted)	-	20 Days
	Acrylic Modesty Panel	-	10-20 Days
	Aura	-	15-20 Days

* 19 or less: 2-3 weeks, 20 or more: 4 weeks

PRODUCT CATEGORY	MODELS	1-10 UNITS	11-25 UNITS	26-50 UNITS	51+ UNITS
Desktop Converters	Winston E-Desk	3 Days	5 Days	7 Days	Call
	Winston Workstation Single*	1 Day	3 Days	5 Days	Call
	Winston Workstation Dual*	1 Day	3 Days	5 Days	Call
	Winston Workstation Triple*	3 Days	5 Days	7 Days	Call
	Winston Workstation Quad*	3 Days	5 Days	7 Days	Call
	Winston-E Single	3 Days	5 Days	7 Days	Call
	Winston-E Dual	3 Days	5 Days	7 Days	Call
	Winston-E Triple	3 Days	5 Days	7 Days	Call
	One Touch Single	20 Days	20 Days	20 Days	Call
	One Touch Dual	20 Days	20 Days	20 Days	Call
	One Touch Triple	20 Days	20 Days	20 Days	Call
	One Touch One over One	20 Days	20 Days	20 Days	Call
	One Touch Two over Two	20 Days	20 Days	20 Days	Call
One Touch Three over Three	20 Days	20 Days	20 Days	Call	

* Finish 248 (White) has a 20 Day lead time.

MONITOR ARMS LEAD TIMES

ALL LEAD TIMES REFLECT BUSINESS DAYS

MODELS	1-10 UNITS	11-25 UNITS	26-50 UNITS	51+ UNITS
Envoy Single	3 Days	5 Days	7 Days	Call
Envoy Dual	3 Days	5 Days	7 Days	Call
E2 Single	Next Day	3 Days	5 Days	Call
E2 Dual	Next Day	3 Days	5 Days	Call
Staxx	3 Days	5 Days	7 Days	Call

MODELS	1-49 UNITS	50-149 UNITS	150+ UNITS
E2 Connex	20 Days	Call	Call
7000 Single*	2 Days	3 Days	Call
7000 Dual*	2 Days	3 Days	Call
7000 Dual Crossbar	2 Days	3 Days	Call
7500	2 Days	4 Days	Call

* Finish 248 (White) has a 20 Day lead time.

STORAGE LEAD TIMES

ALL LEAD TIMES REFLECT BUSINESS DAYS

MODELS	IN-STOCK FINISH LEAD TIME	STANDARD FINISH LEAD TIME
HAT Mobile Pedestal Slim	3 Days	-
HAT Mobile Pedestal	3 Days	-
HAT Mobile Pedestal Cushions	3 Days	8-12 Weeks 50 minimum order qty.
Collective Storage Mobile Locker	Call	-
Collective Storage Mobile Pedestal Slim	Call	-
Collective Storage Mobile Pedestal	Call	-
Collective Storage Mobile Credenza 30"	Call	-
Collective Storage Mobile Credenza 48"	Call	-
Collective Storage Cushions	Call	Call

SEATING LEAD TIMES

ALL LEAD TIMES REFLECT BUSINESS DAYS

MODELS	IN-STOCK FINISH LEAD TIME	STANDARD FINISH LEAD TIME
Iku*	3 Days	Call

* Orders over 50, please call.

ACCESSORIES LEAD TIMES

MODELS	LEAD TIMES
Surface Power Modules	3 Days
Wire Management Sleeve	3 Days
Cable Management Sleeve	3 Days
Casters	3 Days
CPU Holders	3 Days
Docking Station	3 Days

MODELS	1-10 UNITS	11-25 UNITS	26-50 UNITS	51+ UNITS
Slider	20 Days	20 Days	20 Days	Call

IN-STOCK PROGRAM

In-Stock products ship in three business days or less.

In-Stock products include:

- Bases
- Power and Data Beams
- Benching
- Worksurfaces (limited skus)
- Mobile Workstations
- Dividers (limited skus)
- Mobile Pedestals
- Seating (limited skus)

Accessories

- Surface Mounted Power
- Wire Management Sleeve
- Cable Management Tray
- Casters
- CPU Holders
- Docking Station

* For more information, please contact your sales representative.

CERTIFICATIONS

HAT Collective leads the way in exceptional quality by combining products that perform with award winning design. We pride ourselves on meeting and exceeding industry standards so customers can feel confident they have invested in quality, high-performing products that will last.

CLEAN AIR GOLD

ANSI/BIFMA e3-2019, Sections 7.6.1, 7.6.2, 7.6.3: Open Plan Office and Private Office

Number: CA-88279-2021a, CA-81406-2021a, CA-80639-2021a, and CA-80639-2021b

Certification Status: Certified

Certification Period(s): Valid thru 1/09/2025

UL 962 / CE / TUV MARKINGS

HAT bases meet UL testing standards.

ANSI / BIFMA

HAT products within this price list generally meet or exceed applicable BIFMA and ANSI standards.

LEED CREDITS

HAT bases qualify for a variety of LEED credits.



WORKSTATIONS

HAT Collective workstations epitomize innovative design and functionality, helping to easily create an active, productive office environment. Sleek aesthetic and quality construction come together to provide a beautiful, healthy, and personalized work experience. Our standard product line offers unmistakable European flare and our in-stock bases are ideal for quick installations.

Problem solving for a complex environment or specific requests? Our Enhanced Design Solutions program enables total customization through professional design support and direct access to our manufacturing team.

To complete your personalized work environment, add power, modesty panels, storage, and more to create a comprehensive HAT Collective workspace.



WORKSTATIONS

STATEMENT OF LINE

BASES

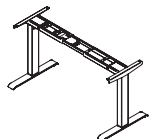

Mid HAT, 2-Stage

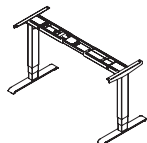

Hi HAT, 3-Stage

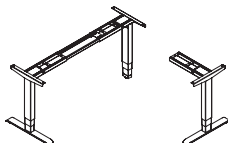

HAT L Unit, 3-Leg

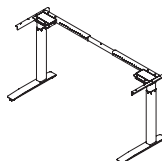

S-Collection
SE 2-Leg, 2-Stage

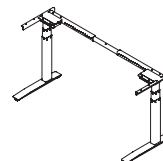

S-Collection
SX 2-Leg, 3-Stage

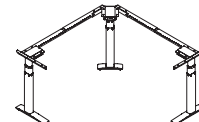

S-Collection
3-Leg, 2-Stage or 3-Stage

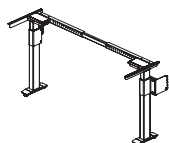

S-Collection
Panel Mounted

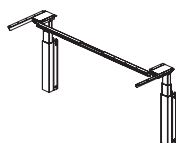

S-Collection
Wall Mount

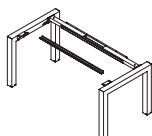

Elle

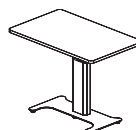

M-Series Freestanding

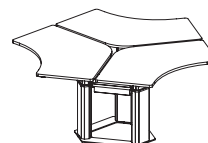

M-Series Tripod

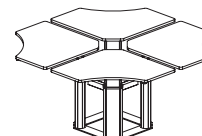

M-Series Quad

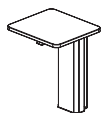

M-Series Wall Mount

POWER & DATA BEAM

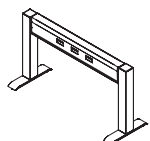

Beam Frames



Dual Benching Unit

GROUP & CONFERENCE

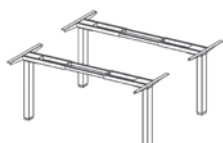

Conference Table

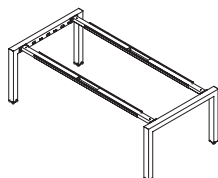

Ellehaven

WORKSURFACES



Rectangle

WORKSTATIONS

STATEMENT OF LINE

MOBILE



M-Series Nesting

DESKTOP CONVERTERS

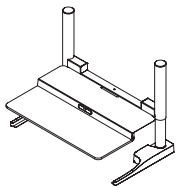

Winston E-Desk

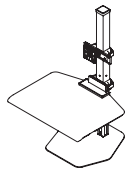

Winston Workstation Single

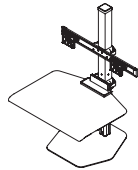

Winston Workstation Dual

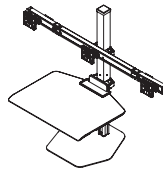

Winston Workstation Triple

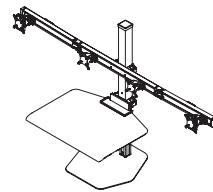

Winston Workstation Quad

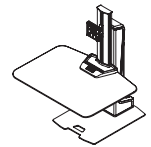

Winston-E Single

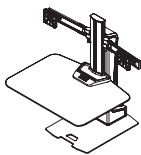

Winston-E Dual

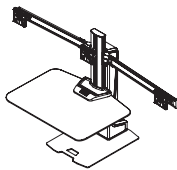

Winston-E Triple

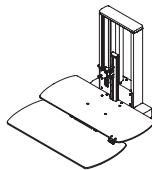

One Touch Single

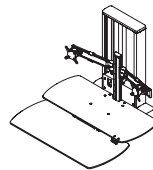

One Touch Dual

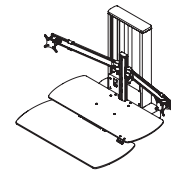

One Touch Triple

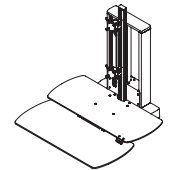

One Touch One over One

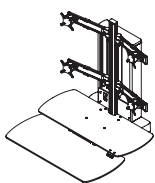

One Touch Two over Two

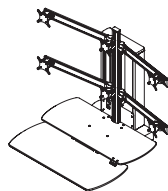

One Touch Three over Three

DIVIDERS



Surface Mount
(PET, Fabric, Acrylic
& White Board)

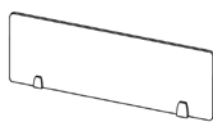

Beam Mount
(PET, Fabric, Acrylic
& White Board)



Slide
(PET)

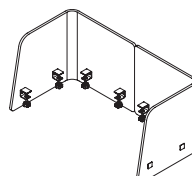

Wrap
(PET)

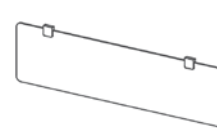

Modesty Panel
(Acrylic)

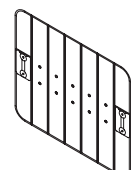

Aura

HAT BASES

OVERVIEW

MID HAT, 2-STAGE

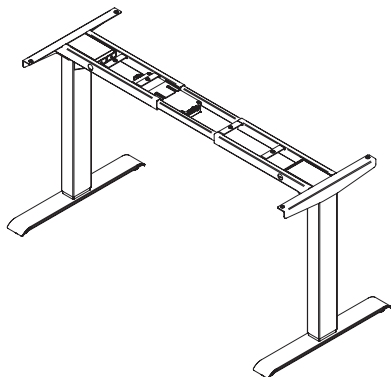

- Electric height adjustable table base (2 Legs)
- Exclusive, easy to assemble, folding frame design
- Expandable width frame (S: 24"- 41", L: 42"- 72")
- 2 stage legs adjust from 27.25"- 46.75" (frame height)
- LED 3 position programmable handset
- Dual sync motors / 300 lb. lift capacity (including top)
- Cable manager included
- Anti collision safety function
- BIFMA, UL, CE, TUV and GreenGuard Gold Certified
- Qualifies for LEED credits
- Raises at 1.2" per second
- C-Foot model available

HI HAT, 3-STAGE

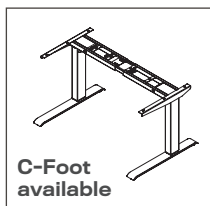
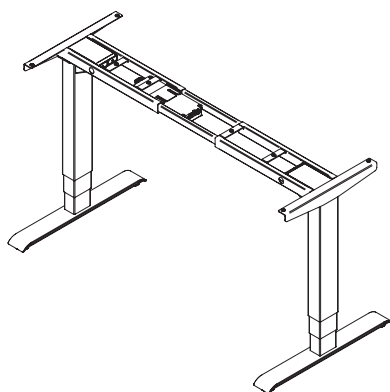

- Electric height adjustable table base (2 Legs)
- Exclusive, easy to assemble, folding frame design
- Expandable width frame (S: 24"- 41", L: 42"- 742)
- 3 stage legs adjust from 23.75"- 49" (frame height)
- LED 3 position programmable handset
- Dual sync motors / 300 lb. lift capacity (including top)
- Cable manager included
- Anti collision safety function
- BIFMA, UL, CE, TUV and GreenGuard Gold Certified
- Qualifies for LEED credits
- Raises at 1.5" per second
- C-Foot model available

HAT L UNIT

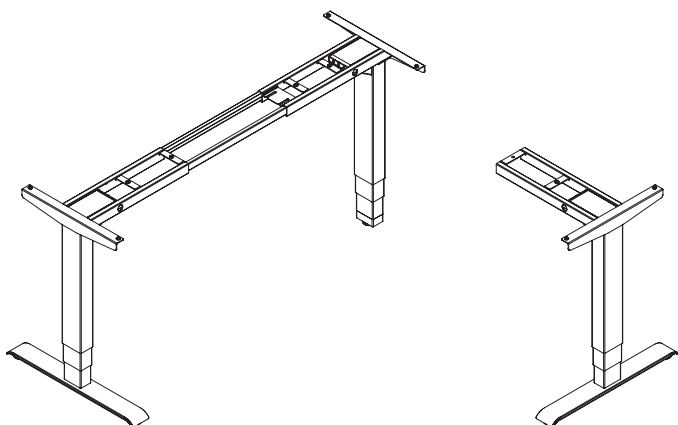

- Electric height adjustable table base (3 Legs)
- Exclusive, easy to assemble, folding frame design
- Expandable width frame (L: 42"- 72")
- 3 stage legs adjust from 23.75"- 49" (frame height)
- LED 3 position programmable handset
- Tri sync motors / 350 lb. lift capacity (including top)
- Cable manager included
- Anti collision safety function
- BIFMA, UL, CE, TUV and GreenGuard Gold Certified
- Qualifies for LEED credits
- Raises at 1.5" per second

MID HAT BASES

2-STAGE

	MODEL	FOOT	TOP SIZE RECOMMENDED		WEIGHT	LIST PRICE
			WIDTH	DEPTH		
Rectangular, 2 Legs 	HAT2-MID-S-__	T-Foot	28" - 45"	24" - 30"	64 lbs.	\$1,034
	HAT2-MID-L-__	T-Foot	46" - 72"	24" - 30"	68 lbs.	\$1,034
	HAT2-MID-S-C24-__	C-Foot, 24"	28" - 45"	24"	64 lbs.	\$1,034
	HAT2-MID-L-C24-__	C-Foot, 24"	46" - 72"	24"	68 lbs.	\$1,034
	HAT2-MID-S-C27-__	C-Foot, 27"	28" - 45"	30"	64 lbs.	\$1,034
	HAT2-MID-L-C27-__	C-Foot, 27"	46" - 72"	30"	68 lbs.	\$1,034

Description:

- Expandable width frame (S: 24"- 41", L: 42"- 72")
- Lead time on C-Foot bases: 8-12 weeks

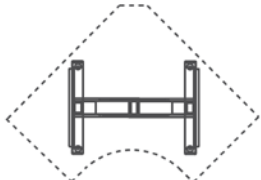
Corner Unit, 2 Legs 	HAT2-MID-S-__	T-Foot	36" - 48"/36" - 48"	24" - 30"	64 lbs.	\$1,034
	HAT2-MID-S-C24-__	C-Foot, 24"	36" - 48"/36" - 48"	24"	64 lbs.	\$1,034
	HAT2-MID-S-C27-__	C-Foot, 27"	36" - 48"/36" - 48"	30"	64 lbs.	\$1,034

Description:

- Lead time on C-Foot bases: 8-12 weeks

Note: For corner units over 48" wide use the HAT3-HI-L 3-Leg Base (See L Unit section on page 19)

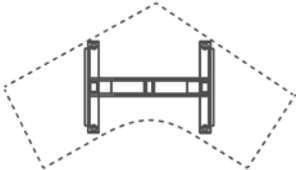
120 Degree Unit, 2 Legs 	HAT2-MID-S-__	T-Foot	36" - 48"/36" - 48"	24" - 30"	64 lbs.	\$1,034
	HAT2-MID-S-C24-__	C-Foot, 24"	36" - 48"/36" - 48"	24"	64 lbs.	\$1,034
	HAT2-MID-S-C27-__	C-Foot, 27"	36" - 48"/36" - 48"	30"	64 lbs.	\$1,034

Description:

- Lead time on C-Foot bases: 8-12 weeks

Note: For 120 Degree corner units over 48" wide order the HAT3-HI-L 3-Leg Base (See L Unit section on page 19)

Please specify color:

SI = Silver, WH = White, BK = Black
 DM = Industrial Steel Antique, HC = Industrial Steel Matte
 (DM and HC are special order only, upcharge applies)

Add code to end of model number.

Example: HAT2-MID-S-SI

Notes:

- See page 19 for table frame specifications
- Worksurfaces not included
- Stocked in silver, white, black
- Custom color match available - standard lead times apply
- DM and HC: 2 Leg List Upcharge = \$70
- C-Foot models are not an in-stock item, standard lead times apply

HI HAT BASES

3-STAGE

	MODEL	FOOT	TOP SIZE RECOMMENDED		WEIGHT	LIST PRICE
			WIDTH	DEPTH		
Rectangular, 2 Legs 	HAT2-HI-S-__	T-Foot	28" - 45"	24" - 30"	70 lbs.	\$1,259
	HAT2-HI-L-__	T-Foot	46" - 72"	24" - 30"	74 lbs.	\$1,259
	HAT2-HI-S-C24-__	C-Foot, 24"	28" - 45"	24"	70 lbs.	\$1,259
	HAT2-HI-L-C24-__	C-Foot, 24"	46" - 72"	24"	74 lbs.	\$1,259
	HAT2-HI-S-C27-__	C-Foot, 27"	28" - 45"	30"	70 lbs.	\$1,259
	HAT2-HI-L-C27-__	C-Foot, 27"	46" - 72"	30"	74 lbs.	\$1,259

Description:

- Expandable width frame (S: 24"- 41", L: 42"- 72")
- Lead time on C-Foot bases: 8-12 weeks

Corner Unit, 2 Legs 	HAT2-HI-S-__	T-Foot	36" - 48"/36" - 48"	24" - 30"	70 lbs.	\$1,259
	HAT2-HI-S-C24-__	C-Foot, 24"	36" - 48"/36" - 48"	24"	70 lbs.	\$1,259
	HAT2-HI-S-C27-__	C-Foot, 27"	36" - 48"/36" - 48"	30"	70 lbs.	\$1,259

Description:

- Lead time on C-Foot bases: 8-12 weeks

Note: For corner units over 48" wide use the HAT3-HI-L 3-Leg Base (See L Unit section below)

120 Degree Unit, 2 Legs 	HAT2-HI-S-__	T-Foot	36" - 48"/36" - 48"	24" - 30"	70 lbs.	\$1,259
	HAT2-HI-S-C24-__	C-Foot, 24"	36" - 48"/36" - 48"	24"	70 lbs.	\$1,259
	HAT2-HI-S-C27-__	C-Foot, 27"	36" - 48"/36" - 48"	30"	70 lbs.	\$1,259

Description:

- Lead time on C-Foot bases: 8-12 weeks

Note: For 120 Degree corner units over 48" wide order the HAT3-HI-L 3-Leg Base (See L Unit section below)

L Unit, 3-Legs 	HAT3-HI-L-__	T-Foot	48" - 84"/48" - 84"	24" - 30"	100 lbs.	\$1,889
--------------------------------------------------------------------------------------------------------------	--------------	--------	---------------------	-----------	----------	---------

Notes:

- This 3-leg base adjusts for multiple sizes of L-shaped units
- This 3-leg base cannot be used with a 3-piece top
- This 3-leg base is used for 120 Degree corner units over 48" wide

Example:

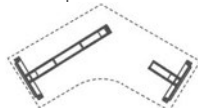

Please specify color:

SI = Silver, WH = White, BK = Black
 DM = Industrial Steel Antique, HC = Industrial Steel Matte
 (DM and HC are special order only, upcharge applies)

Add code to end of model number.

Example: HAT2-HI-S-SI

Notes:

- See page 19 for table frame specifications
- Worksurfaces not included
- Stocked in silver, white, black
- Custom color match available - standard lead times apply
- DM and HC: 2 Leg List Upcharge = \$70, 3 Leg List Upcharge = \$105
- C-Foot models are not an in-stock item, standard lead times apply

S-COLLECTION

OVERVIEW

SPECIFICATIONS	SE 2-STAGE	SX 3-STAGE	3-LEG 2-STAGE or 3-STAGE
Height Range* (Including 1.125" worksurface)	27.1" - 45.6"	22.2" - 48.7"	2-Stage: 27.1" - 45.6" 3-Stage: 22.2" - 48.7"
Frame-Only Weight Load*	350 lbs.	350 lbs.	525 lbs.
Adjustment Speed Per Second	1.5"	1.5"	1.5"
Worksurface Leg Configuration	2, 3 Legs	2, 3 Legs	3 Legs
Standard Color Options	Silver, Black, White	Silver, Black, White	Silver, Black, White
National Electric Code Compliant	Yes	Yes	Yes
ETL Listed to UL 962**	Yes	Yes	Yes

* Wall Mount not included.

** Panel Mount and Wall Mount not included.

SWITCH

Digital Switch included.



DS Digital Switch

3 programmable positions, digital display for height read-out (in cm or inch), up/down controls.

FRAME FINISHES



S (30)
Silver



B (10)
Black



W (04)
White

WORKSURFACE LAMINATE FINISHES

See page 64 for standard worksurfaces.



DW
Designer
White



MM
Manitoba
Maple



FC
Fawn
Cypress



PW
Pinnacle
Walnut

8 GAUGE METAL FOOT	CODE	FOOT LENGTH	TABLE DEPTH OPTIONS
10" Centered	C	9.85" (250mm)	Panel Mount and 3-Leg Center Only
17" Cantilevered	S	15.76" (400mm)	17" - 30" (3-Leg Only)
22" Cantilevered	M	21.56" (547.6mm)	22" - 27"
28" Cantilevered	L	27.56" (700mm)	28" - 30"
28" Conference T-Foot	T	27.56" (700mm)	28" - 50" (42" - 50" for Conference Only)*

* Worksurface depth above 30" is not ETL listed.

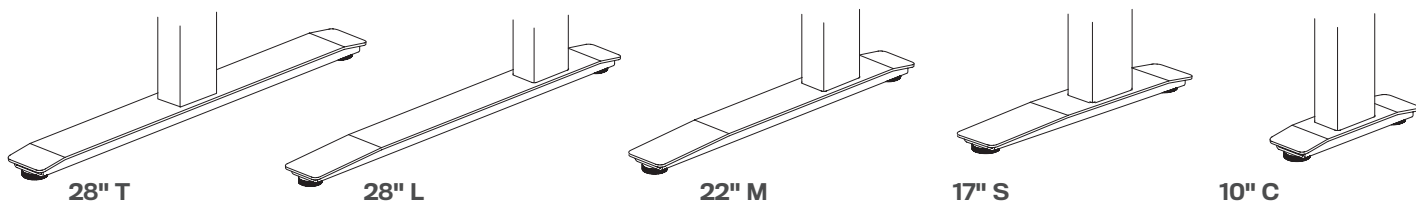

WORKSURFACE SHAPES & CROSSBARS

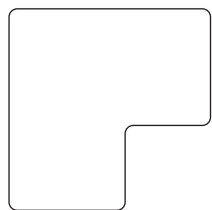

90°
3-Leg
Equal Returns

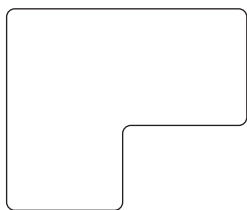

90°
3-Leg
Long Right Return

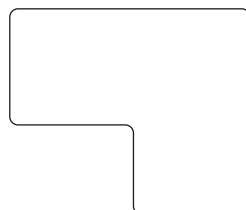

90°
3-Leg
Long Left Return

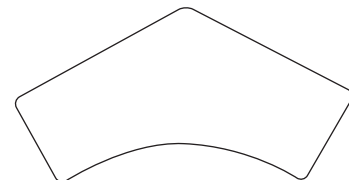

120°
2-Leg & 3-Leg
Equal Returns

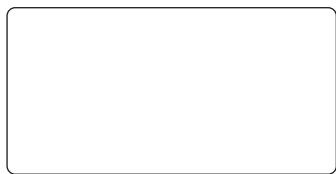

RECTANGULAR
2-Leg

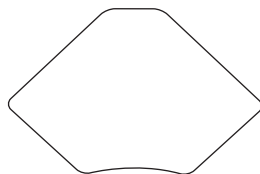

90°
2-Leg

A Crossbar = 36" - 48" **B** Crossbar = 49" - 72" **C** Crossbar = 73" - 90" **F** Fixed Crossbar = Additional Sizes

Additional worksurface dimensions and specifications available upon request.
Shape and size of worksurface determines crossbar needed.
Crossbar adjusts in 1" increments.

S-COLLECTION ORDER FRAME

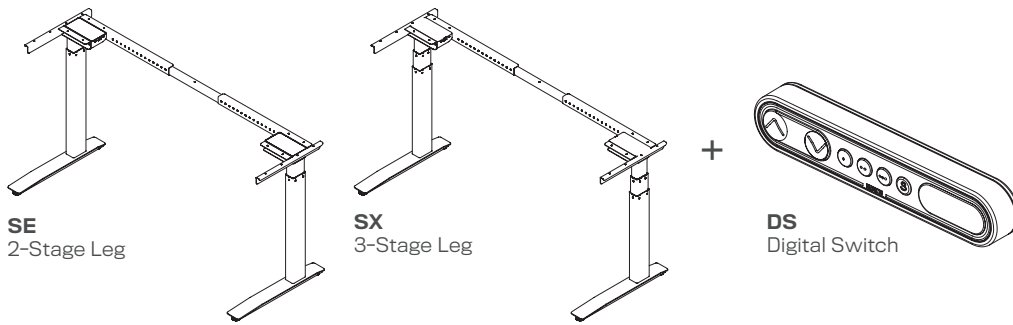

Product Name: Specify product name to determine height adjustability.

Frame Model: Obtain model information from charts on pricing pages.

Frame Color: Specify **B** (black), **W** (white), **S** (silver).

Switch: Specify **DS** (digital)



SX2 & SE2 FRAME ONLY

FRAME ONLY WITH 22" CANTILEVER L FEET

Depth Range: 22" - 27"

Height Range: 2-Stage, 27.1" - 45.6"
3-Stage, 22.2" - 48.7"

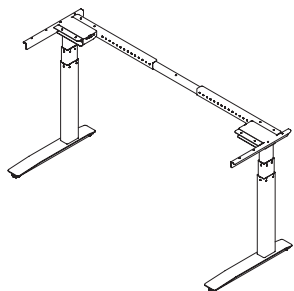

WORKSURFACE SIZES RECOMMENDED

See page 64 for standard worksurfaces.

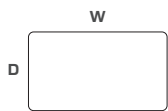

RECTANGULAR

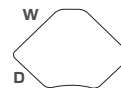

90° CORNER



120°

MODEL	SX2	SE2
	3-Stage	2-Stage
A-MM	\$2,630	\$1,446
B-MM	\$2,859	\$1,536

W	D	W	D	W	D
36" - 48"	22" - 27"	-	-	36" - 41"	22" - 27"
49" - 72"	22" - 27"	-	-	42" - 48"	22" - 27"

FRAME ONLY WITH 28" CANTILEVER L FEET

Depth Range: Rectangular, 28" - 30"
90° Corner & 120°, 24" - 30"

Height Range: 2-Stage, 27.1" - 45.6"
3-Stage, 22.2" - 48.7"

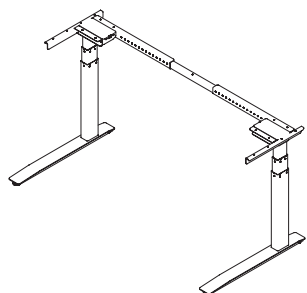

WORKSURFACE SIZES RECOMMENDED

See page 64 for standard worksurfaces.



RECTANGULAR



90° CORNER



120°

MODEL	SX2	SE2
	3-Stage	2-Stage
A-LL	\$2,797	\$1,490
B-LL	\$2,920	\$1,581

W	D	W	D	W	D
36" - 48"	28" - 30"	40" - 48"	24" - 30"	36" - 41"	24" - 30"
49" - 72"	28" - 30"	-	-	42" - 48"	24" - 30"



SX2 & SE2 FRAME ONLY

FRAME ONLY WITH 22" CANTILEVER L FEET, CC CROSSBAR

Depth Range: 22" - 27"

Height Range: 2-Stage, 27.1" - 45.6"
3-Stage, 22.2" - 48.7"

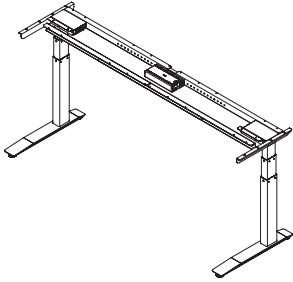

WORKSURFACE SIZES RECOMMENDED

See page 64 for standard worksurfaces.

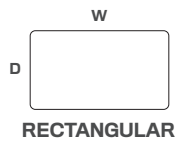

MODEL	SX2 3-Stage	SE2 2-Stage
CC-MM	\$3,217	\$1,894

W	D
73" - 96"	22" - 27"

FRAME ONLY WITH 28" CANTILEVER L FEET, CC CROSSBAR

Depth Range: 28" - 30"

Height Range: 2-Stage, 27.1" - 45.6"
3-Stage, 22.2" - 48.7"

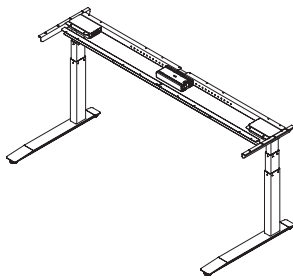

WORKSURFACE SIZES RECOMMENDED

See page 64 for standard worksurfaces.

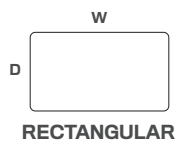

MODEL	SX2 3-Stage	SE2 2-Stage
CC-LL	\$3,278	\$1,939

W	D
73" - 96"	28" - 30"



SX2 & SE2 FRAME ONLY

FRAME ONLY WITH 28" T FEET

Depth Range: 28" - 30"

Height Range: 2-Stage, 27.1" - 45.6"
3-Stage, 22.2" - 48.7"

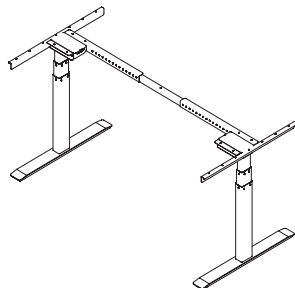

WORKSURFACE SIZES RECOMMENDED

See page 64 for standard worksurfaces.

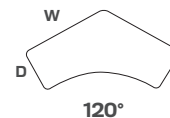
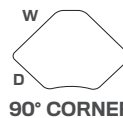
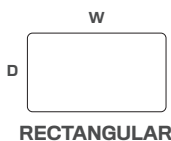

MODEL	SX2 3-Stage	SE2 2-Stage
A-TT	\$2,797	\$1,490
B-TT	\$2,920	\$1,581

W	D	W	D	W	D
36" - 48"	28" - 30"	40" - 48"	28" - 30"	36" - 41"	28" - 30"
49" - 72"	28" - 30"	-	-	42" - 48"	28" - 30"

FRAME ONLY WITH 28" T FEET, CC CROSSBAR

Depth Range: 28" - 30"

Height Range: 2-Stage, 27.1" - 45.6"
3-Stage, 22.2" - 48.7"

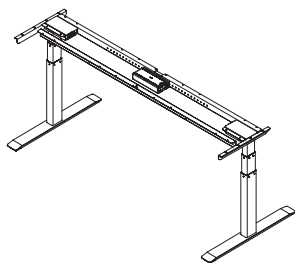

WORKSURFACE SIZES RECOMMENDED

See page 64 for standard worksurfaces.

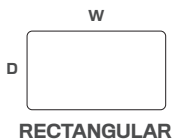

MODEL	SX2 3-Stage	SE2 2-Stage
CC-TT	\$3,278	\$1,939

W	D
73" - 96"	28" - 30"



FRAME ONLY WITH WALL MOUNT

Depth Range: 24" - 30"

Height Range: 2-Stage, 27.1" - 45.6"
3-Stage, 22.2" - 48.7"

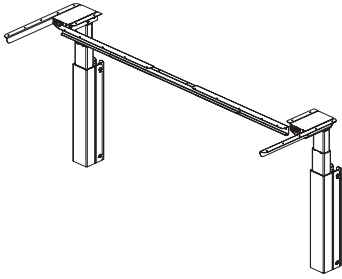

WORKSURFACE SIZES RECOMMENDED

See page 64 for standard worksurfaces.

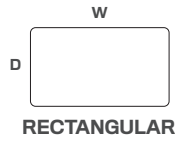

MODEL	SX2 WM	SE2 WM
	3-Stage	2-Stage
A-WM	\$2,879	\$1,635
B-WM	\$2,996	\$1,721

W	D
36" - 48"	24" - 30"
49" - 72"	24" - 30"





SX2 & SE2 PANEL MOUNT FRAME ONLY

FRAME ONLY FOR RECTANGULAR WORKSURFACE

10" Feet

Height Range: 2-Stage, 27.1" - 45.6"
3-Stage, 22.2" - 48.7"

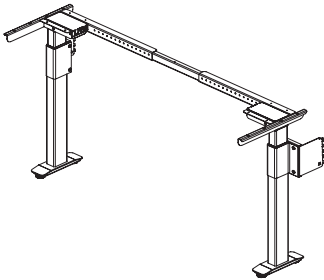

WORKSURFACE SIZES RECOMMENDED

See page 64 for standard worksurfacesp.

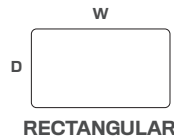

MODEL	PANEL	SX2	SE2	W	D
		3-Stage	2-Stage		
A-CC	PM**	\$2,910	\$1604	35" - 47"	22" - 30"
B-CC	PM**	\$3,034	\$1,694	48" - 71"	22" - 30"

For panel integration systems not listed, please contact your sales rep for a custom quote. Extended lead times may apply subject to HAT Engineering Review.

**AVAILABLE PANEL INTEGRATIONS

Steelcase Answer	01	Knoll Reff	05
Steelcase Avenir	15	Knoll Autostrad	05
Haworth Compose	02	Knoll Dividends	11
Haworth Unigroup	03	Allsteel	06
Herman Miller Canvas	02	Dirtt Wall	07
Herman Miller A02	04	AIS Divi	10
Teknion Leverage	02	AIS M Wall	10

SX3 & SE3 FRAME ONLY

FRAME ONLY FOR 90° WORKSURFACE

17" Cantilever Feet

Height Range: 2-Stage, 27.1" - 45.6"
3-Stage, 22.2" - 48.7"

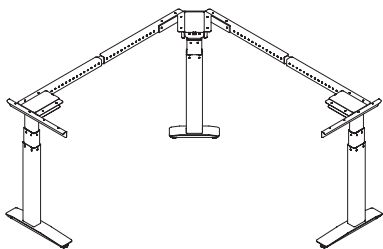

WORKSURFACE SIZES RECOMMENDED

See page 64 for standard worksurfaces.

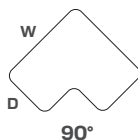

MODEL	SX3	SE3
	3-Stage	2-Stage
AA-SS-C	\$3,220	\$2,168
BB-SS-C	\$3,276	\$2,259

W	D
42" - 54"	22" - 30"
54" - 78"	22" - 30"

SXV3 & SEV3 FRAME ONLY

FRAME ONLY FOR 120° WORKSURFACE

22" or 28" Cantilever Feet

Height Range: 2-Stage, 27.1" - 45.6"
3-Stage, 22.2" - 48.7"

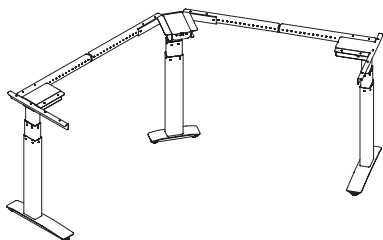

WORKSURFACE SIZES RECOMMENDED

See page 64 for standard worksurfaces.



MODEL	SXV3	SEV3
	3-Stage	2-Stage
BB-MM-C	\$3,333	\$2,283
BB-LL-C	\$3,389	\$2,372

W	D
60" - 78"	22" - 27"
60" - 78"	28" - 30"





FIELLØ®

OVERVIEW

SPECIFICATIONS	FIELLØ
Height Range (frame only)	21.1" - 47.6"
Fiellø Frame Only Weight Capacity	350 lbs.
Adjustment Speed Per Second	1.5"
Worksurface Leg Configuration	2 Legs
Foot	27.5" L foot

SWITCH



PH Personal Health Assistant Tracker

4 programmable positions, LED reminder indicates when to change your position, Bluetooth® integration, digital display for height read-out (in cm or inch), tilt up/down for height adjust.

* The Bluetooth® integration is available for both your computer and your phone (iOS and Android) and gives you the power to set your standing goals.

METAL FINISHES



S Silver
B Black
W White

WORKSURFACE FINISHES



Linen Tier 1: LNLN (Matte) Tier 2: LVLN (Fingerprint resistant)	Feather Tier 1: - Tier 2: FVPD (Fingerprint resistant)	Platinum* Tier 1: PLPL (Matte) Tier 2: PVPL (Fine velvet)	Charcoal Tier 1: - Tier 2: CVCH (Traceless)	Black* Tier 1: BLBL (Matte) Tier 2: BVBL (Traceless)
-------------------------------------------------------------------------------------------	------------------------------------------------------------------------	-------------------------------------------------------------------------------------	-------------------------------------------------------------	--------------------------------------------------------------------------------

PANEL FINISHES

Recycled PET

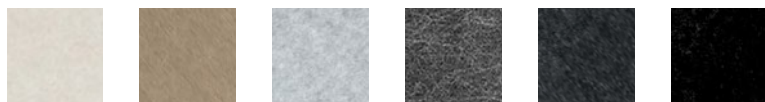

FOA Oatmeal
FLA Latte
FPE Pebble
FSL Slate
FNI Night
FBL Black

Wood Veneer



WO Oak
WW Walnut

DRAWER FINISHES



WO Oak
WW Walnut

FL2-L-30 FRAME

MODEL	FINISH	LIST PRICE
FL2-L-30	METAL	\$2,675

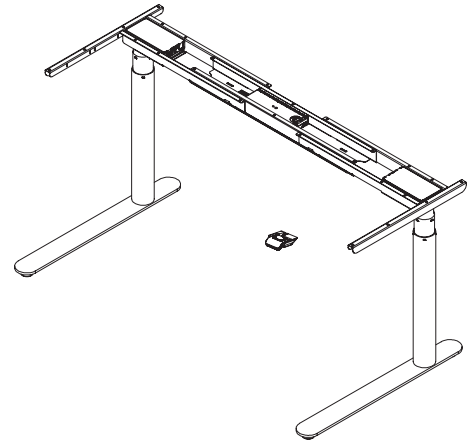

F2T WORKSURFACE

MODEL	A	B	FINISH	LIST PRICE
6030	60"	30"	TIER 1 WORKSURFACE	\$1,197
6030	60"	30"	TIER 2 WORKSURFACE	\$1,835
7230	72"	30"	TIER 1 WORKSURFACE	\$1,197
7230	72"	30"	TIER 2 WORKSURFACE	\$1,701

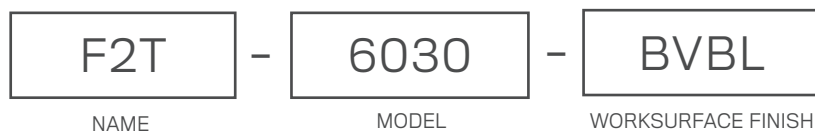
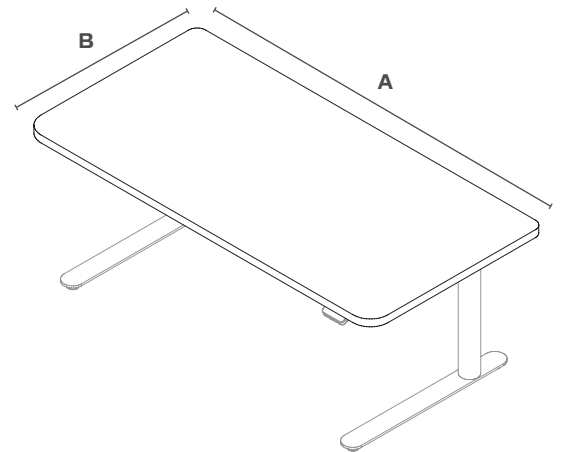

RP RIBBON PANEL (2 PANELS)

MODEL	A	B	C	FINISH	LIST PRICE
MP-RP-X-FFF	30.5"	13.75"	16"	PET	\$1,107
MP-RP-X-WO	30.5"	13.75"	16"	WOOD	\$1,542
MP-RP-X-WW	30.5"	13.75"	16"	WOOD	\$1,674

X = METAL BRACKET FINISH
 FFF = RECYCLED PET FINISH
 WO = WOOD, OAK VENEER FINISH
 WW = WOOD, WALNUT VENEER FINISH

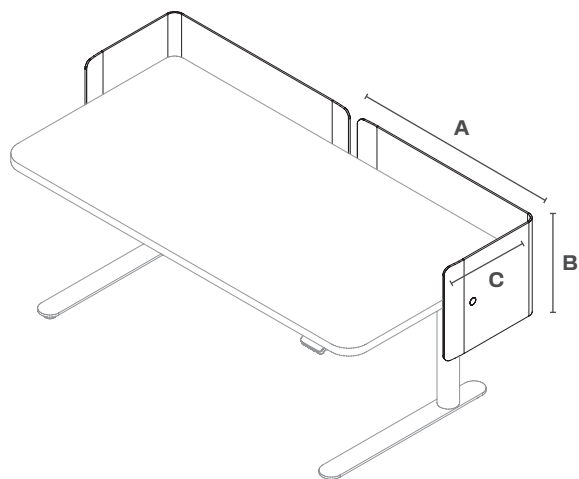

FP FULL PANEL (2 PANELS)

MODEL	A	B	C	FINISH	LIST PRICE
MP-FP-X-FFF	30.5"	30"	16"	PET	\$1,466
MP-FP-X-WO	30.5"	30"	16"	WOOD	\$3,449
MP-FP-X-WW	30.5"	30"	16"	WOOD	\$2,976

X = METAL BRACKET FINISH
 FFF = RECYCLED PET FINISH
 WO = WOOD, OAK VENEER FINISH
 WW = WOOD, WALNUT VENEER FINISH

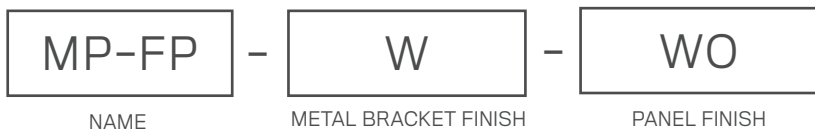
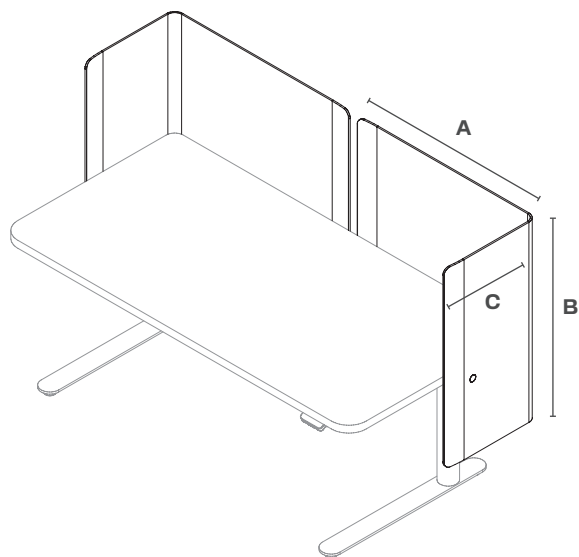

DR DRAWER

MODEL*	A	B	C	FINISH	LIST PRICE
DR-SM-X-WO	15.75"	.7"	14.5"	METAL & WOOD	\$682
DR-SM-X-WW	15.75"	.7"	14.5"	METAL & WOOD	\$549

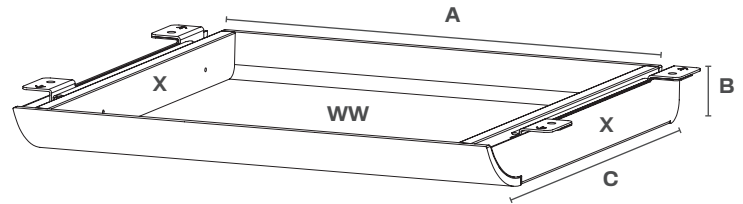

X = METAL
 WO = WOOD, OAK VENEER FINISH
 WW = WOOD, WALNUT VENEER FINISH



BH BAG HOOK

MODEL	A	B	C	FINISH	LIST PRICE
BH-X	1.5"	2.33"	1.18"	METAL	\$44.00

X = METAL

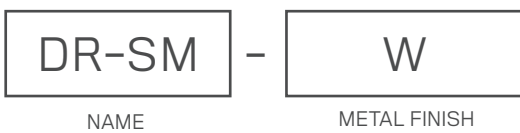
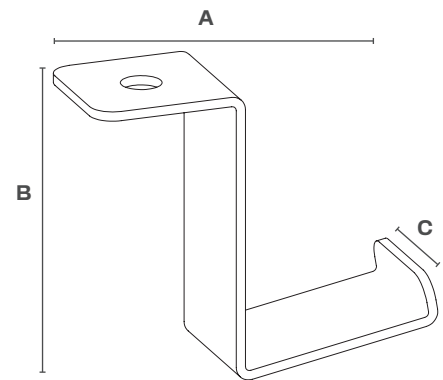



M-SERIES FRAMES

OVERVIEW

SPECIFICATIONS	FREESTANDING	NESTING	WALL MOUNT	BENCHING
Height Range*	27.6" - 44.1"	28.6" - 45.1"	29.4" - 45.9" **	27.6" - 44.1"
Frame-Only Weight Load	15 - 105 lbs.	15 - 25 lbs.	15 - 60 lbs.	15 - 105 lbs.
Column Selections	UL, L, M, H	UL	UL, L	UL, L, M, H
Base Options	H, X	N	WM	TP, Q
Standard Color Options	Silver, Black, White	Silver, Black, White	Silver, Black, White	Silver, Black, White

*Including 1.125" worksurface.

**When placed at the recommended height of 3" from the floor.

AVERAGE TASK LOAD WEIGHTS

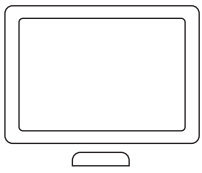

Monitor
5-7 lbs.

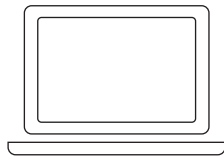

Laptop
5-10 lbs.

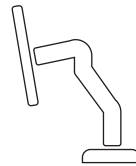

Monitor Arm
12-15 lbs.

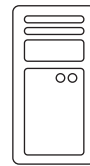

CPU
18-20 lbs.

COLUMN SELECTION EQUATION

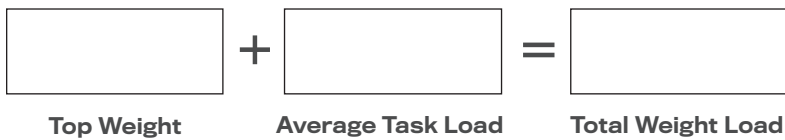

**Frame only
Weight Load**

- 15 - 32 lbs.
- 33 - 46 lbs.
- 47 - 63 lbs.
- 64 - 81 lbs.
- 82 - 105 lbs.

Column Option

- UL** Ultra Light
- ULP** Ultra Light+
- L** Light
- M** Medium*
- H** Heavy*

* Not available for Nesting or Wall Mount.

5/16" METAL PLATE	CODE	# OF GLIDES	TABLE DEPTH OPTIONS	WORKSURFACE SHAPE
Organic H	H	6*	24" - 30"	Rectangular
Organic X	X	8*	30"	Rectangular
Nesting	N	4	22"	Petal
Wall Mount	WM	-	18" - 24"	Rectangular
Tripod Bench	TP	6	18" - 24"	120°
Quad Bench	Q	8	18" - 24"	90°

* Casters available for additional cost.

BASES

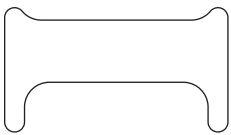

H
Organic H

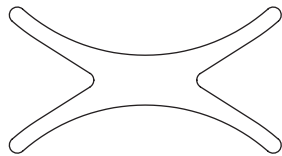

X
Organic X

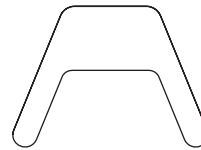

N
Nesting

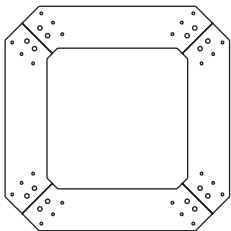

Q
Quad Benching

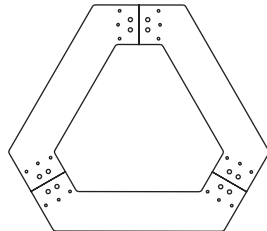

TP
Tripod Benching

FRAME FINISHES



S (30)
Silver



B (10)
Black



W (04)
White

WORKSURFACE LAMINATE FINISHES

See page 46 for standard worksurfaces.



DW
Designer
White



MM
Manitoba
Maple



FC
Fawn
Cypress



PW
Pinnacle
Walnut

M-SERIES ORDER FRAME

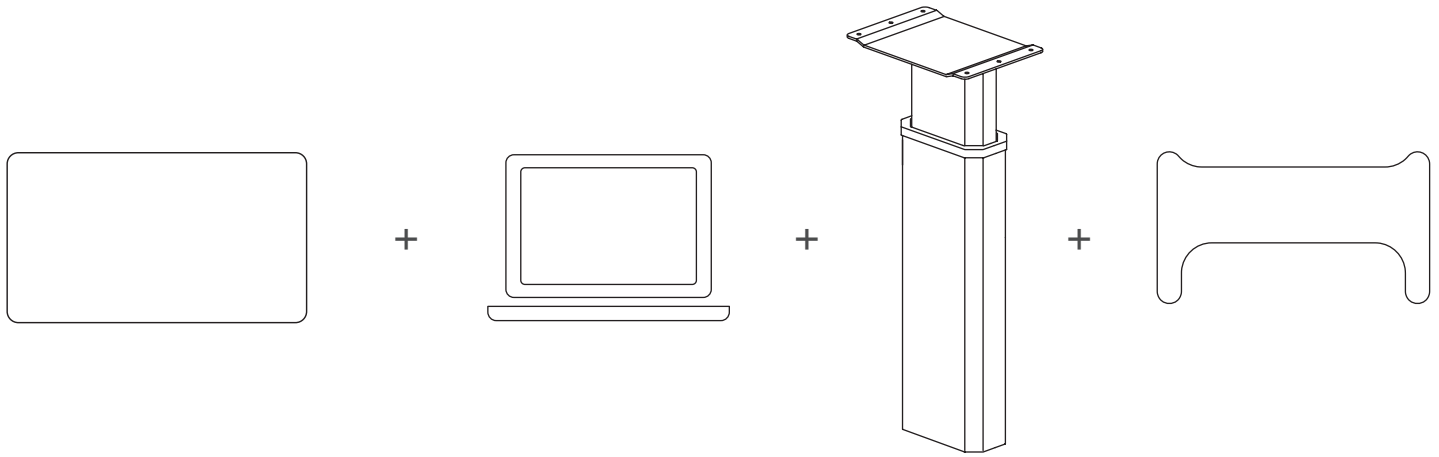

1. Determine Worksurface Weight
See page 46 for standard worksurfaces.

2. Worksurface Average Task Load

3. Column Selection

4. Choose Base

Product Name: Specify product name to determine height adjustability.

Frame Model: Obtain model information from charts on pricing pages.

Base Option: Specify **H** (organic h), **X** (organic X).

Column Option: Specify **UL** (ultra light), **ULP** (ultra light plus), **L** (light), **M** (medium), **H** (heavy).

Frame Color: Specify **B** (black), **W** (white), **S** (silver).

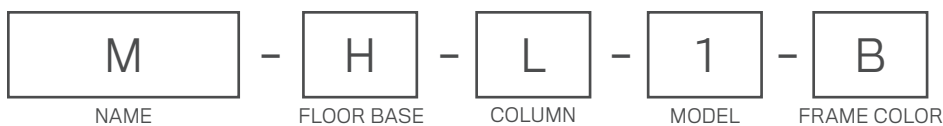

M-SERIES FREESTANDING FRAME ONLY

M COLUMN & H BASE

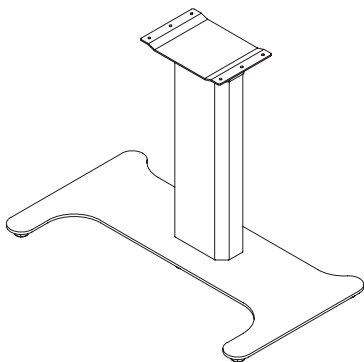

WORKSURFACE SIZES RECOMMENDED

See page 46 for standard worksurfaces.

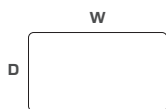

RECTANGULAR



90° CORNER



120°

MODEL	H BASE
0	\$1,408
1	\$1,408

RECTANGULAR		90° CORNER		120°	
W	D	W	D	W	D
30" - 47"	24" - 30"	42" - 48"	24"	42"	24"
48" - 54"	24" - 30"				

Pricing reflects frame only.

M COLUMN & X BASE

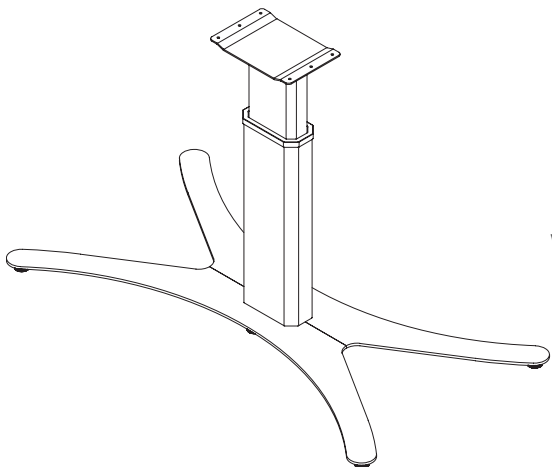

WORKSURFACE SIZES RECOMMENDED

See page 46 for standard worksurfaces.



RECTANGULAR

MODEL	X BASE
2	\$1,429

W	D
55" - 60"	30"

Pricing reflects frame only.

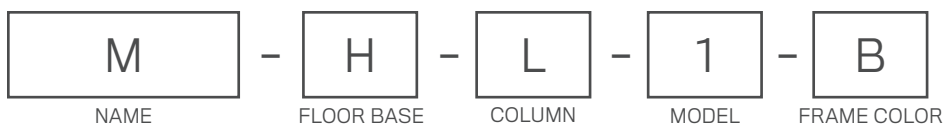

M-SERIES NESTING FRAME ONLY

NP COLUMN & BASE (INCLUDING CASTERS)

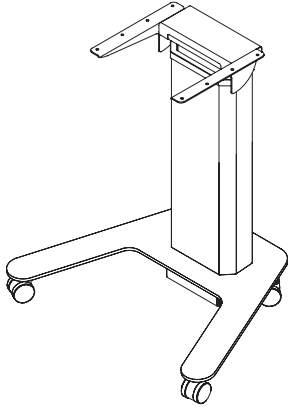

WORKSURFACE SIZES RECOMMENDED

See page 46 for standard worksurfaces.

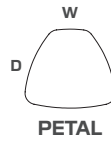

MODEL	LIST PRICE
N	\$1,039

W	D
28"	22"

Pricing reflects frame only.

* M-Series Nesting table is only available with an Ultra Light column with a petal shaped top and V shaped nesting base.



M-SERIES WALL MOUNT FRAME ONLY

WM COLUMN, & BASE

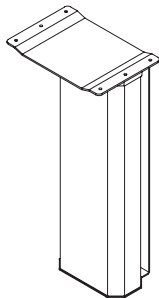

WORKSURFACE SIZES RECOMMENDED

See page 46 for standard worksurfaces.

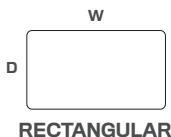

MODEL	LIST PRICE
WM	\$1,197

W	D
20" - 48"	18" - 24"

Pricing reflects frame only.

M-SERIES WALL MOUNT WITH TILT FRAME ONLY

WMT COLUMN, & BASE

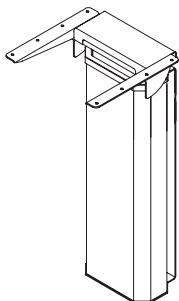

WORKSURFACE SIZES RECOMMENDED

See page 46 for standard worksurfaces.

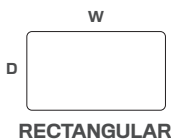

MODEL	LIST PRICE
WMT	\$1,225

W	D
20" - 48"	18" - 24"

Pricing reflects frame only.



M-SERIES TRIPOD FRAME ONLY

M-TP COLUMN & BASE

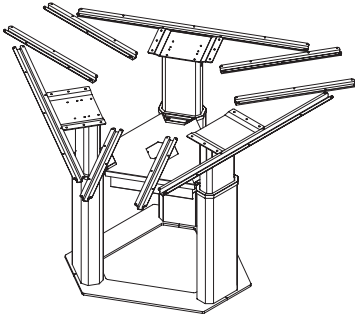

WORKSURFACE SIZES RECOMMENDED

See page 47 for standard worksurfaces.



W **D**

24" - 40" 18" - 24"

MODEL	LIST PRICE
M-TP	\$4,924

Pricing reflects frame only.

M-SERIES QUAD FRAME ONLY

M-Q COLUMN & BASE

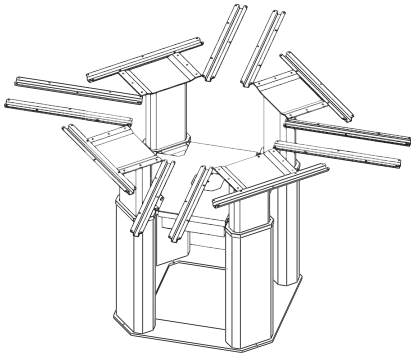

WORKSURFACE SIZES RECOMMENDED

See page 47 for standard worksurfaces.



W **D**

24" - 40" 18" - 24"





MODEL	LIST PRICE
M-Q	\$6,636

Pricing reflects frame only.





WORKSURFACES FOR M-SERIES FREESTANDING, NESTING, WALL

ORGANIC H BASE	MODEL	DEPTH	WIDTH	WEIGHT	LIST PRICE
Rectangular 	M1T-3624-H-_____	24"	36"	27 lbs.	\$954
	M1T-4224-H-_____	24"	42"	31 lbs.	\$1,003
	M1T-4824-H-_____	24"	48"	36 lbs.	\$1,146
	M1T-5424-H-_____	24"	54"	40 lbs.	\$1,289
	M1T-3630-H-_____	30"	36"	28 lbs.	\$1,074
	M1T-4230-H-_____	30"	42"	39 lbs.	\$1,253
	M1T-4830-H-_____	30"	48"	45 lbs.	\$1,432
	M1T-5430-H-_____	30"	54"	50 lbs.	\$1,611
ORGANIC X BASE					
Rectangular 	M1T-5430-X-_____	30"	54"	40 lbs.	\$1,611
	M1T-6030-X-_____	30"	60"	56 lbs.	\$1790
N BASE					
Petal 	M1T-2822-N-_____	22"	28"	16 lbs.	\$935
WALL MOUNT					
Rectangular 	M1T-2018-WM-_____	18"	20"	12 lbs.	\$831
	M1T-2024-WM-_____	24"	20"	15 lbs.	\$883
	M1T-2418-WM-_____	18"	24"	13.5 lbs.	\$914
	M1T-3024-WM-_____	24"	30"	22.5 lbs.	\$945
	M1T-3624-WM-_____	24"	36"	27 lbs.	\$954
	M1T-4224-WM-_____	24"	42"	31 lbs.	\$1,003
	M1T-4824-WM-_____	24"	48"	36 lbs.	\$1,146
WALL MOUNT WITH TILT					
Rectangular 	M1T-2018-WMT-_____	18"	20"	12 lbs.	\$831
	M1T-2024-WMT-_____	24"	20"	15 lbs.	\$883
	M1T-2418-WMT-_____	18"	24"	13.5 lbs.	\$914
	M1T-3024-WMT-_____	24"	30"	22.5 lbs.	\$945
	M1T-3624-WMT-_____	24"	36"	27 lbs.	\$954
	M1T-4224-WMT-_____	24"	42"	31 lbs.	\$1,003
	M1T-4824-WMT-_____	24"	48"	36 lbs.	\$1,146

WORKSURFACE LAMINATE FINISHES

(Surface Edge: Matching)



DW
Designer
White



MM
Manitoba
Maple



FC
Fawn
Cypress



PW
Pinnacle
Walnut



Please specify color:

PW = Pinnacle Walnut, FC = Fawn Cypress, MM = Manitoba Maple, DW = Designer White

Add code to end of model number.

Example: M1T-3624-H-PWPW

WORKSURFACES FOR M-SERIES TRIPOD & QUAD

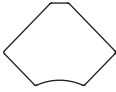
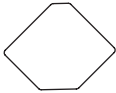
TRIPOD	MODEL	DESCRIPTION	DEPTH	WIDTH	WEIGHT	LIST PRICE
120° Curved 	M1T3-MV-TP-3618-_____	Set of 3	18"	36"	43 lbs. per top	\$5,925
	M1T3-MV-TP-3624-_____	Set of 3	24"	36"	45 lbs. per top	\$6,081
	M1T3-MV-TP-4018-_____	Set of 3	18"	40"	51 lbs. per top	\$6,212
	M1T3-MV-TP-4024-_____	Set of 3	24"	40"	51 lbs. per top	\$6,343
120° Straight 	M1T3-MV-TP-3618S-_____	Set of 3	18"	36"	43 lbs. per top	\$5,925
	M1T3-MV-TP-3624S-_____	Set of 3	24"	36"	45 lbs. per top	\$6,081
	M1T3-MV-TP-4018S-_____	Set of 3	18"	40"	51 lbs. per top	\$6,212
	M1T3-MV-TP-4024S-_____	Set of 3	24"	40"	51 lbs. per top	\$6,343
QUAD						
90° Curved 	M1T3-MC-Q-3618-_____	Set of 4	18"	36"	35 lbs. per top	\$4,156
	M1T3-MC-Q-3624-_____	Set of 4	24"	36"	37 lbs. per top	\$4,364
	M1T3-MC-Q-4018-_____	Set of 4	18"	40"	42 lbs. per top	\$4,967
	M1T3-MC-Q-4024-_____	Set of 4	24"	40"	45.5 lbs. per top	\$5,088
90° Straight 	M1T3-MC-Q-3618S-_____	Set of 4	18"	36"	35 lbs. per top	\$4,156
	M1T3-MC-Q-3624S-_____	Set of 4	24"	36"	37 lbs. per top	\$4,364
	M1T3-MC-Q-4018S-_____	Set of 4	18"	40"	42 lbs. per top	\$4,967
	M1T3-MC-Q-4024S-_____	Set of 4	24"	40"	45.5 lbs. per top	\$5,088

WORKSURFACE LAMINATE FINISHES

(Surface Edge: Matching)



DW
Designer
White



MM
Manitoba
Maple



FC
Fawn
Cypress



PW
Pinnacle
Walnut

Please specify color:

PW = Pinnacle Walnut, FC = Fawn Cypress, MM = Manitoba Maple, DW = Designer White

Add code to end of model number.

Example: M1T3-MV-TP-3618-PWPW

ELLEHAVEN FRAMES

OVERVIEW

SPECIFICATIONS	FRAME ONLY
Height Range	27" - 46.7"
Frame-Only Weight Load	450 lbs.
Adjustment Speed Per Second	1.5"
Standard Color Options	Silver, Black, White
Width Options	84", 96", 108", 120"
Depth Options	36", 42", 48"

ELLE HEIGHT ADJUSTABLE FRAMES

OVERVIEW

SPECIFICATIONS	FRAME ONLY
Height Range	27" - 46.7"
Available With Sliding Worksurface	No
Frame-Only Weight Load	400 lbs.
Adjustments Speed Per Second	1.5"
Standard Color Options	Silver, Black, White
Width Options	48" - 72"
Depth Options	30"

ELLE STATIC FRAMES

OVERVIEW

SPECIFICATIONS	FRAME ONLY
Height Options	28", 42"
Frame-Only Weight Load	400 lbs.
Standard Color Options	Silver, Black, White
Width Options	48" - 72"
Depth Options	30"

SWITCH *ELLEHAVEN, ELLE HEIGHT ADJUSTABLE

Digital Switch included.



DS Digital Switch

3 programmable positions, digital display for height read-out (in cm or inch), up/down controls.

FRAME FINISHES



S (30)
Silver



B (10)
Black



W (04)
White

WORKSURFACE LAMINATE FINISHES

See pages 54 & 55 for standard worksurfaces.



DW
Designer
White



MM
Manitoba
Maple



FC
Fawn
Cypress



PW
Pinnacle
Walnut

ELLE HEIGHT ADJUSTABLE FRAME ONLY

EL FRAME ONLY

FRAME OPTIONS:

FOT Frame Only Top Mounted **FOE** Frame Only Enshrined Mounted **FTS** Frame Only Top Sliding **FES** Frame Only Enshrined Sliding

FOT	FOE	FTS	FES	W	D
\$2,543	\$2,543	\$2,712	\$2,712	48" - 72"	30"

Frame only for sliding worksurface maximum opening width is 5".
Rear fixed worksurface is 9" deep and front sliding worksurface is 21".

FOT
Frame Only
Top Mounted

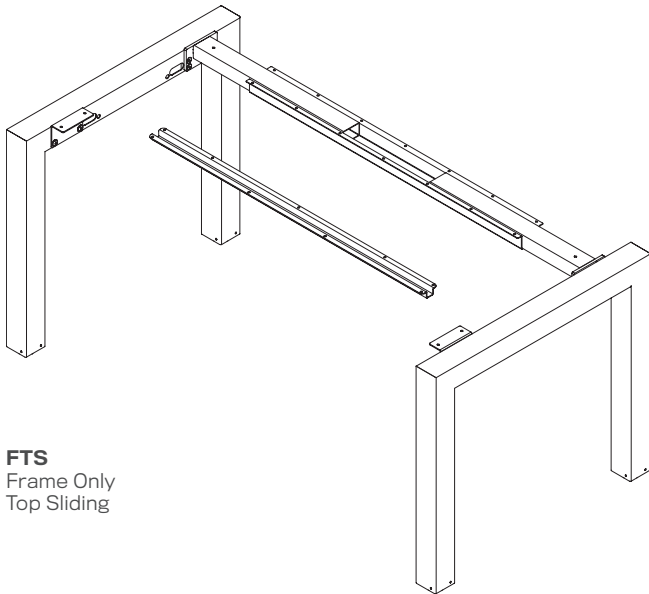

FTS
Frame Only
Top Sliding

FOE
Frame Only
Enshrined
Mounted

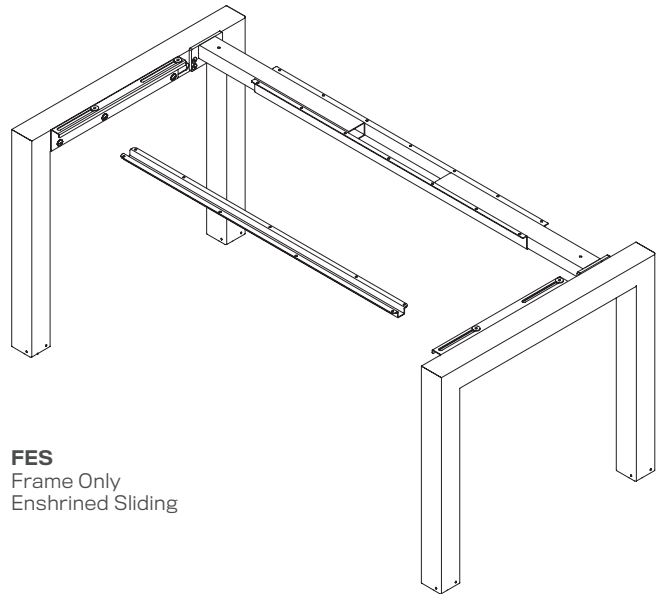

FES
Frame Only
Enshrined Sliding

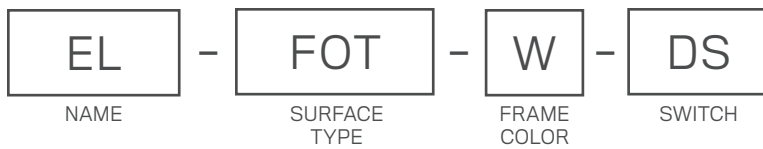

ELLE STATIC FRAME ONLY

EL FRAME ONLY

FRAME OPTIONS:

FOT Frame Only Top Mounted

MODEL	FOT	W	D	H
28	\$1,533	48" - 72"	30"	28"
42	\$1,655	48" - 72"	30"	42"

FOT

Frame Only
Top Mounted

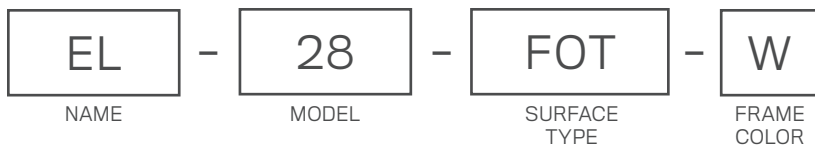
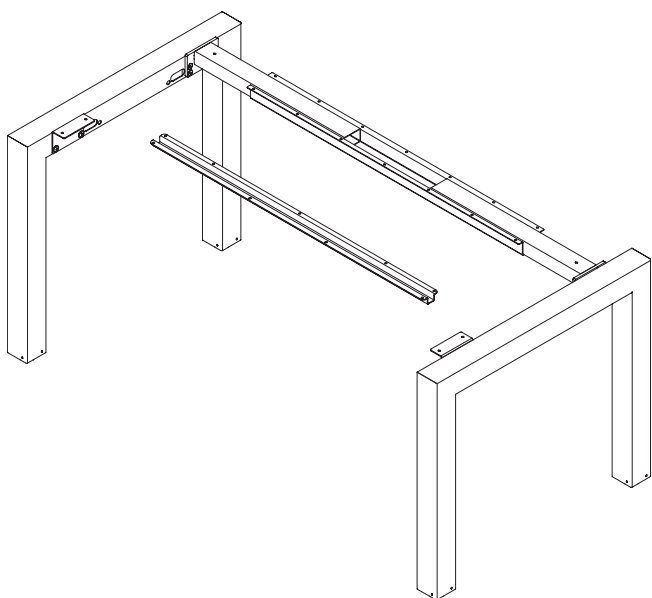

ELLEHAVEN FRAME ONLY

EH Frame Only

MODEL	W	D	LIST PRICE
A-36	72" - 96"	36"	\$4,575
B-36	108" - 120"	36"	\$4,913
A-42	72" - 96"	42"	\$4,631
B-42	108" - 120"	42"	\$4,970
A-48	72" - 96"	48"	\$4,687
B-48	108" - 120"	48"	\$5,026

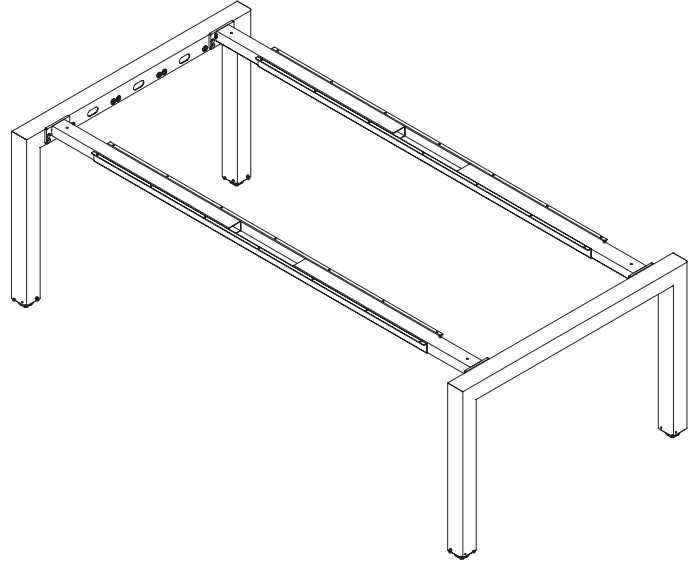



WORKSURFACES FOR ELLE

OVERVIEW

TOP	MODEL	DEPTH	WIDTH	WEIGHT	LIST PRICE
Rectangular 	EL1T-6030-TM-_____	30"	60"	56 lbs.	\$1,147
	EL1T-7230-TM-_____	30"	72"	67 lbs.	\$1,376

ENSHRINED

Rectangular 	EL1T-6030-EM-_____	30"	60"	56 lbs.	\$1,147
	EL1T-7230-EM-_____	30"	72"	67 lbs.	\$1,376

TOP SLIDING

Rectangular 	EL1T-6030-TS-_____	30"	60"	56 lbs.	\$1,611
	EL1T-7230-TS-_____	30"	72"	67 lbs.	\$1,871

ENSHRINED SLIDING

Rectangular 	EL1T-6030-ES-_____	30"	60"	56 lbs.	\$1,611
	EL1T-7230-ES-_____	30"	72"	67 lbs.	\$2,258

WORKSURFACE LAMINATE FINISHES

(Surface Edge: Matching)



DW
Designer
White



MM
Manitoba
Maple



FC
Fawn
Cypress



PW
Pinnacle
Walnut

Please specify color:

PW = Pinnacle Walnut, FC = Fawn Cypress, MM = Manitoba Maple, DW = Designer White

Add code to end of model number.

Example: EL1T-7230-ES-PWPW

WORKSURFACES FOR ELLEHAVEN

OVERVIEW

	MODEL	DEPTH	WIDTH	WEIGHT	LIST PRICE
Rectangular 	EH1T-8436-_____	36"	84"	94 lbs.	\$2,140
	EH1T-8442-_____	42"	84"	110 lbs.	\$2,497
	EH1T-8448-_____	48"	84"	126 lbs.	\$2,854
	EH1T-9636-_____	36"	96"	108 lbs.	\$2,446
	EH1T-9642-_____	42"	96"	126 lbs.	\$2,854
	EH1T-9648-_____	48"	96"	144 lbs.	\$3,261
	EH1T-10836-_____	36"	108"	121 lbs.	\$2,752
	EH1T-10842-_____	42"	108"	141 lbs.	\$3,210
	EH1T-10848-_____	48"	108"	162 lbs.	\$3,669
	EH1T-12036-_____	36"	120"	135 lbs.	\$3,058
	EH1T-12042-_____	42"	120"	157 lbs.	\$3,567
	EH1T-12048-_____	48"	120"	180 lbs.	\$4,077

WORKSURFACE LAMINATE FINISHES

(Surface Edge: Matching)

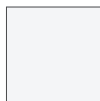
**DW**
Designer
White**MM**
Manitoba
Maple**FC**
Fawn
Cypress**PW**
Pinnacle
Walnut**Please specify color:**

PW = Pinnacle Walnut, FC = Fawn Cypress, MM = Manitoba Maple, DW = Designer White

Add code to end of model number.

Example: EH1T-8436-PWPW

POWER & DATA BEAM

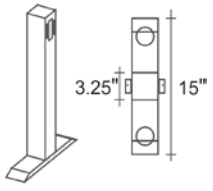
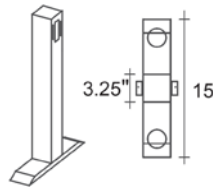
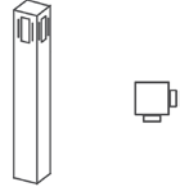
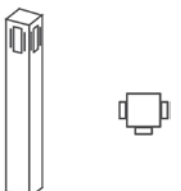
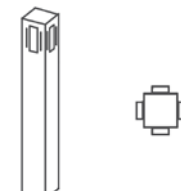





	MODEL	SIZE	WEIGHT	LIST PRICE
<p>End Post with Foot</p> 	HRPF23-E-__	23" x 3.25" x 3.25"	7 lbs.	\$259
	<p>Note:</p> <ul style="list-style-type: none"> · Post ships with 15" foot 			
<p>180 Degree Post with Foot</p> 	HRPF23-180-__	23" x 3.25" x 3.25"	7 lbs.	\$285
	<p>Note:</p> <ul style="list-style-type: none"> · Post ships with 15" foot 			
<p>L Post, 2 Way</p> 	HRP24-L-__	24" x 3.25" x 3.25"	5 lbs.	\$224
	<p>Note:</p> <ul style="list-style-type: none"> · Post ships with a leveling glide 			
<p>T Post, 3 Way</p> 	HRP24-T-__	24" x 3.25" x 3.25"	5 lbs.	\$247
	<p>Note:</p> <ul style="list-style-type: none"> · Post ships with a leveling glide 			
<p>X Post, 4 Way</p> 	HRP24-X-__	24" x 3.25" x 3.25"	5 lbs.	\$269
	<p>Note:</p> <ul style="list-style-type: none"> · Post ships with a leveling glide 			

Please specify color:
 SI = Silver, WH = White, BK = Black

Add code to end of model number.
Example: HRP24-L-SI

Note:
 · All posts ship with mounting hardware, connecting hinges and top cap

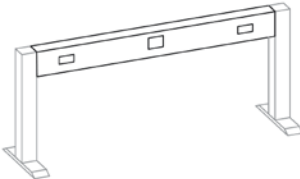
POWER & DATA BEAM

	MODEL	SIZE	WEIGHT	LIST PRICE
120 Degree 2 Way Post	HRP24-2-120-__	24" H	3 lbs.	\$243
	Note: · Post ships with a leveling glide			
				
120 Degree 3 Way Post	HRP24-3-120-__	24" H	3 lbs.	\$267
	Note: · Post ships with a leveling glide			
				
Beam Frame	HRLB-36-__ HRLB-48-__ HRLB-60-__ HRLB-72-__	6" x 36" x 2.75" 6" x 48" x 2.75" 6" x 60" x 2.75" 6" x 72" x 2.75"	8 lbs. 10 lbs. 12 lbs. 15 lbs.	\$742 \$807 \$872 \$937
	Notes: · Raceway covers include 2 outlet cutouts and 1 voice/data cutout · Each raceway cover ships with voice/date cover plate and data jack adapter kit · Posts ordered separately · Beam ships pre-marked to accept beam mounted divider clamps			
Power Pole	PP12-__ PP12-2-__	144" x 3.25" x 3.25" 144" x 3.25" x 3.25"	6 lbs. 6 lbs.	\$618 \$668
	Notes: · Ceiling Power Feed Kit must be ordered separately · Ships with a foot · Includes Ceiling Trim Kit · Compatible with either Beam or Dual Bench			
	PP12: · Can only be installed at end of run			
	PP12-2: · Can be installed in the middle of a run or at the end of run			

Please specify color:

SI = Silver, WH = White, BK = Black

Add code to end of model number.

Example: HRP24-L-SI**Note:**

· All posts ship with mounting hardware, connecting hinges and top cap

POWER & DATA BEAM

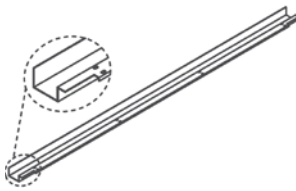
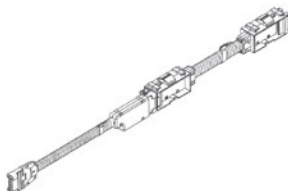
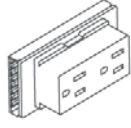
	MODEL	DESCRIPTION	SIZE	WEIGHT	LIST PRICE
Cable Management Tray 	CMT2-36-__	Cable Tray, 36"	4" x 36"	3 lbs.	\$84
	CMT2-48-__	Cable Tray, 48"	4" x 48"	4 lbs.	\$93
	CMT2-60-__	Cable Tray, 60"	4" x 60"	5 lbs.	\$102
	CMT2-72-__	Cable Tray, 72"	4" x 72"	6 lbs.	\$111
	Description: <ul style="list-style-type: none"> · Allows user to lay cables outside of Power Beam · Mounts to underside of beam - one required for each side · Mounts left or right · When ordering for use with a benching system, please order one size smaller than worksurface Example: 72" worksurface: Order a 60" Cable Management Tray · When ordering for use with a power beam, please order the matching size Example: 72" power beam: Order a 72" Cable Management Tray 				
Power Trac 	PT-36	Power Trac, 36" with Jumper	36"	4 lbs.	\$282
	PT-48	Power Trac, 48" with Jumper	48"	5 lbs.	\$298
	PT-60	Power Trac, 60" with Jumper	60"	6 lbs.	\$312
	PT-72	Power Trac, 72" with Jumper	72"	7 lbs.	\$329
	Notes: <ul style="list-style-type: none"> · 4 circuit, 8 wire system · Will accept up to 4 duplex receptacles per Trac (2 per side) 				
Duplex Receptacle 	DR-1	Duplex Receptacle, Circuit 1		1 lb.	\$31
	DR-2	Duplex Receptacle, Circuit 2		1 lb.	\$31
	DR-3	Duplex Receptacle, Circuit 3		1 lb.	\$31
	DR-4	Duplex Receptacle, Circuit 4		1 lb.	\$31
	DR-1-T24	Duplex Receptacle, Circuit 1, Title 24		1 lb.	\$36
	DR-2-T24	Duplex Receptacle, Circuit 2, Title 24		1 lb.	\$36
	DR-3-T24	Duplex Receptacle, Circuit 3, Title 24		1 lb.	\$36
	DR-4-T24	Duplex Receptacle, Circuit 4, Title 24		1 lb.	\$36
	CHBX	Chicago Receptacle Box (sold individually)		1 lb.	\$337
	Notes: <ul style="list-style-type: none"> · DR models ship in color matching Power Beam · For every Beam or Bench, order 2 CHBX (ie: 3 Beam or Bench x 2 CHBX = 6 CHBX) · CHBX is double sided, and accommodates 2 electrician provided receptacles 				

POWER & DATA BEAM

	MODEL	DESCRIPTION	SIZE	WEIGHT	LIST PRICE
Power Feed 	BFK-E	Base Power Feed Kit, End Entry	72"	5 lbs.	\$256
	BFK-S	Base Power Feed Kit, Side Entry	72"	5 lbs.	\$280
	CFK	Ceiling Power Feed Kit	144"	9 lbs.	\$274
	BFK-E-NY-72/72	Base Power Feed Kit, End Entry for New York	72"	10 lbs.	\$446

Notes:

- NFK-E-NY-72/72 is stocked in a common size. Special sizes available upon request: please contact your sales rep for more information
- For complete Title 24 compliant electrical component, please call your sales rep for more information

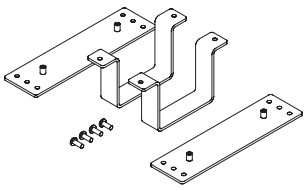
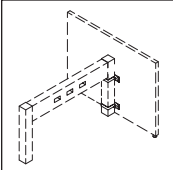
Gallery End Panel Bracket Kit  	GPBRKT-KIT-__				\$201
------------------------------------------------------------------------------------------------------------------------------------------------------------------------------------------------------------------	---------------	--	--	--	-------

Description:

- Allows gallery panels to be attached to power/data beam end post (gallery panels not sold by HAT)
- Kit includes two clamps
- Gallery panels not to exceed 36" H or 63" W
- Compatible with panel thickness of .75" - 1.5"
- End panels with built-in leveling feet recommended
- Wood screws not included

Notes:

- Specify color: Silver (SI) White (WH) Black (BK)

HAT BENCHING

OVERVIEW

HOW TO ORDER

The HAT Benching System was designed to be very simply and easy to specify, order and install.

To specify, please follow these simple steps:

1. Specify a Dual Benching Unit for either a 48", 60" or 72" worksurface.
 This unit includes 2 height adjustable frames (adjusts from 27.25" - 46.75" high) with adjustable glides, 2 horizontal connector bars, a Power Beam and Power Trac with Jumper Connector
2. Specify the Duplex Receptacles, Power Feed type (base or ceiling) and Power Pole (see page 57)
3. Specify a Connector Beam
 The 11.25" Beam is used to connect a Dual Benching Unit to an adjoining Benching Unit or a power pole
4. Specify optional Cable Management Tray (see page 58)
5. Specify optional Dividers (see pages 72-85)
6. Specify Worksurfaces (see page 64)

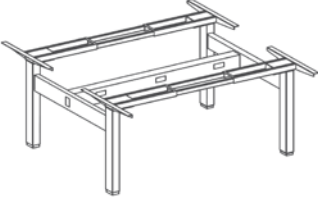
	MODEL	TOP SIZE RECOMMENDED		WEIGHT	LIST PRICE
		WIDTH	DEPTH		
	DBUHAT-48-MID-L-__	48"	24" - 30"	118 lbs.	\$3,617
	DBUHAT-60-MID-L-__	60"	24" - 30"	122 lbs.	\$3,709
	DBUHAT-72-MID-L-__	72"	24" - 30"	126 lbs.	\$3,795

Description:

- Includes 2 height adjustable frames (adjusts 27.5" - 46.75" high)
- Includes 2 horizontal connector bars to connect base legs
- Includes Power Beam
- Includes Power Trac with jumper connector

Notes:

- Duplex Receptacles must be ordered separately
- Base/Ceiling Power Feed must be ordered separately
- Worksurfaces must be ordered separately
- Beam or Surfaces Mounted Dividers must be ordered separately
- Optional Cable Management Tray must be ordered separately
- Available in White, Silver or Black

Please specify color:

SI = Silver, WH = White, BK = Black

Add code to end of model number.

Example: DBUHAT-48-MID-L-SI

Notes:

- Worksurfaces not included
- Stocked in silver, white, black
- Custom color match available - standard lead times apply

HAT BENCHING

TOP SIZE RECOMMENDED

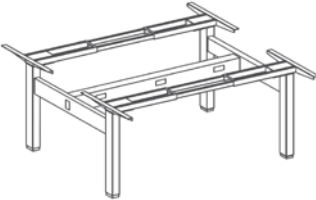
	MODEL	WIDTH	DEPTH	WEIGHT	LIST PRICE
	DBUHAT-48-MID-L-CH-__	48"	24" - 30"	118 lbs.	\$3,369
	DBUHAT-60-MID-L-CH-__	60"	24" - 30"	122 lbs.	\$3,446
	DBUHAT-72-MID-L-CH-__	72"	24" - 30"	126 lbs.	\$3,518

Description:

- Includes 2 height adjustable frames (adjusts 27.5" - 46.75" high)
- Includes 2 horizontal connector bars to connect base legs
- Includes Power Beam
- Please note CH model numbers do not included power trac with jumper connector

Notes:

- Duplex Receptacles must be ordered separately
- CHBX must be ordered separately
- Base/Ceiling Power Feed must be ordered separately
- Worksurfaces must be ordered separately
- Beam or Surfaces Mounted Dividers must be ordered separately
- Optional Cable Management Tray must be ordered separately
- Available in White, Silver or Black

	MODEL	SIZE	WEIGHT	LIST PRICE
	BENCH-9 CONNECT-__	6" x 9" x 2.75"	3 lbs.	\$209
	BENCH-10.5 CONNECT-__	6" x 10.0" x 2.75"	3 lbs.	\$209
	BENCH-11.25 CONNECT-__	6" x 11.25" x 2.75"	3 lbs.	\$209
	BENCH-11.625 CONNECT-__	6" x 11.625" x 2.75"	3 lbs.	\$209

Description:

- Connects 2 sections of Dual Benching
- Jumper cable passes through this beam
- 9" Connect Beam is used to connect to Power Pole
- 10.5" and 11.25" can be used for smaller worksurfaces and when a Mobile Slim Pedestal is not in use between Dual Benching Units
- 11.625" Connector Beam allows a Mobile Slim Pedestal to fit into the dead space between Dual Benching Units

	MODEL	LIST PRICE
Gallery End Panel Bench Bracket Kit	GPBRKT-KIT-BENCH-__	\$201

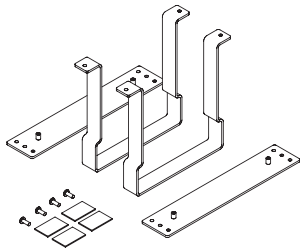

Description:

- Allows gallery panels to be attached to the end of a benching unit (gallery panels not sold by HAT)
- Kit includes two clamps
- Gallery panels not to exceed 36" H or 66" W
- Compatible with panel thickness of .75" - 1.5"
- End panels with built-in leveling feet recommended
- Wood screws not included

Notes:

- Specify color: Silver (SI) White (WH) Black (BK)

Please specify color:

SI = Silver, WH = White, BK = Black

Add code to end of model number.

Example: DBUHAT-48-MID-L-SI

Notes:

- Worksurfaces not included
- Stocked in silver, white, black
- Custom color match available - standard lead times apply

HAT GROUP & CONFERENCE OVERVIEW

GROUP & CONFERENCE TABLE BASE, 2-STAGE

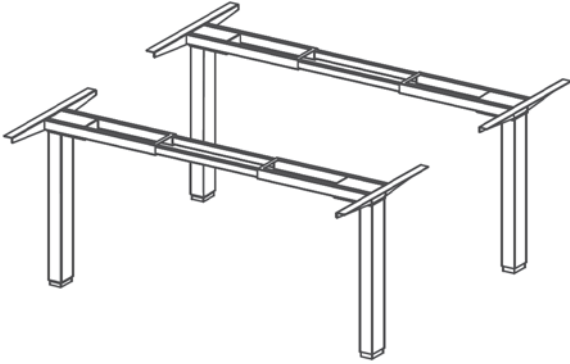

- Electric height adjustable table base (4 Legs)
- Exclusive, easy to assemble, folding frame design
- Expandable width frame (42"- 74")
- 2-stage legs adjust from 27.25"- 46.75" (frame height)
- LED 4 position programmable handset
- Quad sync motors / 350 lb. lift capacity (including top)
- Cable manager included
- Anti collision safety function
- UL, CE, TUV and GREENGUARD GOLD Certified
- Qualifies for LEED credits
- Raises at 1.2" per second

	MODEL	TOP SIZE RECOMMENDED		WEIGHT	LIST PRICE
		WIDTH	DEPTH		
Conference Table Base	HAT4-MID-L-__	72" - 120"	42" - 60"	110 lbs.	\$2,136

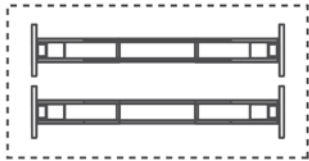

Notes:

- Ships without feet, includes adjustable glides
- Stocked only in black

Please specify color:

BK = Black

Add code to end of model number.

Example: HAT4-MID-L-BK

Notes:

- Worksurface not included
- Stocked in black only



WORKSURFACES FOR MID HAT, HI HAT, L UNIT, HAT BENCHING, S-COLLECTION

WORKSURFACE DETAILS

- Edge Detail: 1.125" LPL/TFL Laminate with 2mm PVC Matching Edge
- Standard Laminate Colors: Designer White (DW), Fawn Cypress (FC), Manitoba Maple (MM), Pinnacle Walnut (PW)
- Grommets not offered

IN-STOCK PROGRAM

- Available in the following finishes and sizes:
 Designer White (DW), Fawn Cypress (FC),
 Manitoba Maple (MM), Pinnacle Walnut (PW)
 30" x 48", 30" x 60", 30" x 72"
- Shipping times:
 1 - 24 units ship in 3 business days from receipt of PO
- Worksurfaces must be ordered with a corresponding base/bench
- Orders under \$2,000 NET will have a freight surcharge

STANDARD SHIP PROGRAM

- Available in: 17 size options, 4 laminates
- Shipping times:
 25 - 249 units ship in 10 - 15 business days from receipt of PO
 250+ units call for lead time
- Worksurfaces must be ordered with a corresponding base/bench
- Orders under \$2,000 NET will have a freight surcharge

	MODEL	DEPTH	WIDTH	WEIGHT	LIST PRICE
Rectangular 	WS-2424- __	24"	24"	14 lbs.	\$291
	WS-2430- __	24"	30"	19 lbs.	\$296
	WS-2436- __	24"	36"	21 lbs.	\$319
	WS-2442- __	24"	42"	24 lbs.	\$323
	WS-2448- __	24"	48"	28 lbs.	\$335
	WS-2454- __	24"	54"	31 lbs.	\$354
	WS-2460- __	24"	60"	35 lbs.	\$373
	WS-2466- __	24"	66"	38 lbs.	\$508
	WS-2472- __	24"	72"	42 lbs.	\$526
	WS-3030- __	30"	30"	22 lbs.	\$307
	WS-3036- __	30"	36"	26 lbs.	\$321
	WS-3042- __	30"	42"	30 lbs.	\$327
	WS-3048- __	30"	48"	35 lbs.	\$347
	WS-3054- __	30"	54"	39 lbs.	\$360
	WS-3060- __	30"	60"	44 lbs.	\$396
	WS-3066- __	30"	66"	48 lbs.	\$517
	WS-3072- __	30"	72"	53 lbs.	\$535

WORKSURFACE LAMINATE FINISHES

(Surface Edge: Matching)



DW
Designer
White



MM
Manitoba
Maple



FC
Fawn
Cypress



PW
Pinnacle
Walnut

Please specify color:

PW = Pinnacle Walnut, FC = Fawn Cypress, MM = Manitoba Maple, DW = Designer White

Add code to end of model number.

Example: WS-3072-PW





DESKTOP CONVERTERS

	MODEL	WEIGHT CAPACITY	SCREEN SIZE	LIST PRICE
Winston E-Desk	WNSTE-DESK	Up to 100 lbs.	Single Monitor: Up to 32" Dual Monitor: Up to 24"	\$1,261

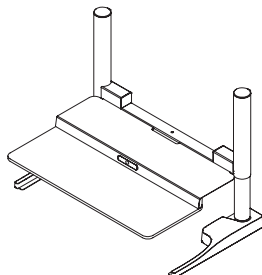

Description:

- Height Adjustment: 19.0"
- Upper Worksurface: 32.25" W x 8.5" D
- Lower Worksurface: 32.25" W x 11.5" D
- Base: 35.5" W x 24.5" D
- Electric height adjustment with touchscreen controls and memory
- Available in White or Black

Notes:

- **Specify color:** White (WHT) Black (BLK)

DESKTOP CONVERTERS

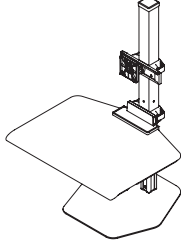
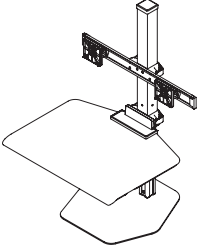
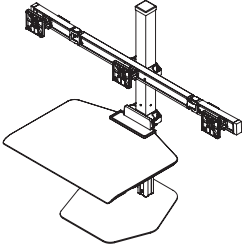
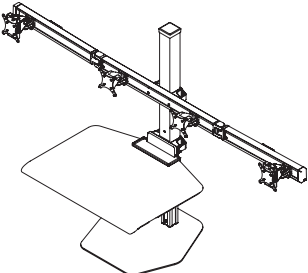
	MODEL	WEIGHT CAPACITY	SCREEN SIZE	LIST PRICE
	Winston Workstation Single WNST-1-___	7 - 20 lbs.	Up to 43"	\$1,197
	Description: <ul style="list-style-type: none"> · Height Adjustment: 17.1" · Worksurface: 30" W x 23" D · Base: 20.7" W x 22" D Notes: <ul style="list-style-type: none"> · Specify color: Black (104) Silver (124) White (248) 			
	Winston Workstation Dual WNST-2-___	10 - 26 lbs.	Up to 27"	\$1,261
	Description: <ul style="list-style-type: none"> · Height Adjustment: 17.1" · Worksurface: 30" W x 23" D · Base: 20.7" W x 22" D Notes: <ul style="list-style-type: none"> · Specify color: Black (104) Silver (124) White (248) 			
	Winston Workstation Triple WNST-3-___	15 - 36 lbs.	Up to 24"	\$1,507
	Description: <ul style="list-style-type: none"> · Height Adjustment: 17.1" · Worksurface: 30" W x 23" D · Base: 20.7" W x 22" D Notes: <ul style="list-style-type: none"> · Specify color: Black (104) Silver (124) White (248) 			
	Winston Workstation Quad WNST-4-___	24 - 40 lbs.	Up to 24"	\$1,876
	Description: <ul style="list-style-type: none"> · Height Adjustment: 17.1" · Worksurface: 30" W x 23" D · Base: 20.7" W x 22" D Notes: <ul style="list-style-type: none"> · Specify color: Black (104) Silver (124) White (248) 			

DESKTOP CONVERTERS

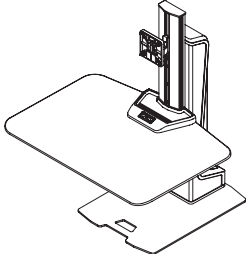
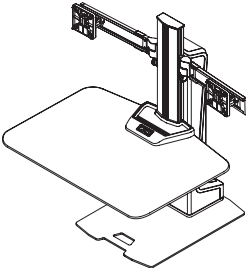
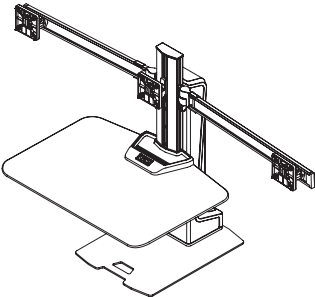
	MODEL	WEIGHT CAPACITY	SCREEN SIZE	LIST PRICE
 <p>Winston-E Single</p>	WNSTE-1-270	Up to 40 lbs.	Up to 43"	\$1,778
	<p>Description:</p> <ul style="list-style-type: none"> · Height Adjustment: 18.4" · Worksurface: 30" W x 22" D · Base: 16" W x 21" D · Electric height adjustment with memory · Available in Grey Duotone 			
 <p>Winston-E Dual</p>	WNSTE-2-270	Up to 40 lbs.	Up to 30"	\$1,976
	<p>Description:</p> <ul style="list-style-type: none"> · Height Adjustment: 18.4" · Worksurface: 30" W x 22" D · Base: 16" W x 21" D · Electric height adjustment with memory · Focal depth and independent monitor height adjustments · Available in Grey Duotone 			
 <p>Winston-E Triple</p>	WNSTE-3-270	Up to 40 lbs.	Up to 24"	\$2,137
	<p>Description:</p> <ul style="list-style-type: none"> · Height Adjustment: 18.4" · Worksurface: 30" W x 22" D · Base: 16" W x 21" D · Electric height adjustment with memory · Focal depth and independent monitor height adjustments · Available in Grey Duotone 			

DESKTOP CONVERTERS

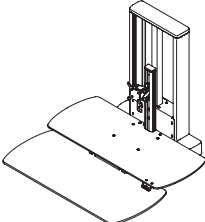
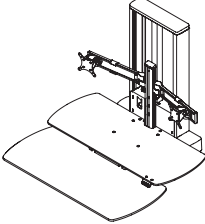
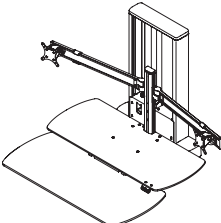
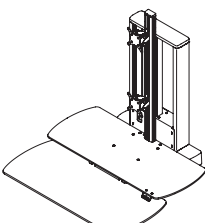
	MODEL	WEIGHT CAPACITY	SCREEN SIZE	LIST PRICE
One Touch Single	1TCH-1-___	up to a 25 lb. monitor 100 lbs. total unit weight capacity	Up to 49"	\$2,192
	Description: · Height Adjustment: 20" · Upper Worksurface: 15" D x 36" W · Lower Worksurface: 17" D x 36" W · Mount: Clamp, Rail	Notes: · Specify color: Black (BLK) Silver (SLV)		
One Touch Dual	1TCH-2-___	up to 15 lbs. per monitor 100 lbs. total unit weight capacity	Up to 32"	\$2,682
	Description: · Height Adjustment: 20" · Upper Worksurface: 15" D x 36" W · Lower Worksurface: 17" D x 36" W · Mount: Clamp, Rail	Notes: · Specify color: Black (BLK) Silver (SLV)		
One Touch Triple	1TCH-3-___	up to 15 lbs. per monitor on wing up to a 25 lb. monitor on column 100 lbs. total unit weight capacity	Up to 24"	\$2,796
	Description: · Height Adjustment: 20" · Upper Worksurface: 15" D x 36" W · Lower Worksurface: 17" D x 36" W · Mount: Clamp, Rail	Notes: · Specify color: Black (BLK) Silver (SLV)		
One Touch One over One	1TCH-1/1-___	up to 25 lbs. per monitor 100 lbs. total unit weight capacity	Up to 49"	\$2,950
	Description: · Height Adjustment: 20" · Upper Worksurface: 15" D x 36" W · Lower Worksurface: 17" D x 36" W · Mount: Clamp, Rail	Notes: · Specify color: Black (BLK) Silver (SLV)		

DESKTOP CONVERTERS

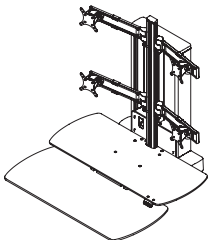
	MODEL	WEIGHT CAPACITY	SCREEN SIZE	LIST PRICE
One Touch Two over Two	1TCH-2/2-___	up to 15 lbs. per monitor 100 lbs. total unit weight capacity	Up to 32"	\$3,251
	Description: <ul style="list-style-type: none"> · Height Adjustment: 20" · Upper Worksurface: 15" D x 36" W · Lower Worksurface: 17" D x 36" W · Mount: Clamp, Rail Notes: <ul style="list-style-type: none"> · Specify color: Black (BLK) Silver (SLV) 			

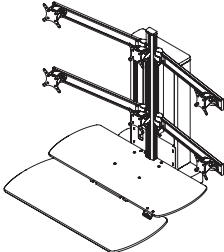
One Touch Three over Three	1TCH-3/3-___	up to 15 lbs. per monitor on wing up to 25 lbs. per monitor on column 100 lbs. total unit weight capacity	Up to 24"	\$3,587
	Description: <ul style="list-style-type: none"> · Height Adjustment: 20" · Upper Worksurface: 15" D x 36" W · Lower Worksurface: 17" D x 36" W · Mount: Clamp, Rail Notes: <ul style="list-style-type: none"> · Specify color: Black (BLK) Silver (SLV) 			

DIVIDERS & MODESTY PANELS

Create privacy in any open environment with our easy-to-install partitions. Dividers add spatial barriers and distinctive design to an office landscape, prioritizing both functionality and aesthetic. Choose from opaque or transparent, permanent or portable to take advantage of the protection, acoustic control, and flexibility provided by HAT Collective dividers.



SURFACE MOUNTED DIVIDERS

IN-STOCK

	MODEL	H	W	LIST PRICE
PET Dividers	EDDI-PET-4824-S	24"	48"	\$408
	EDDI-PET-6024-S	24"	60"	\$480

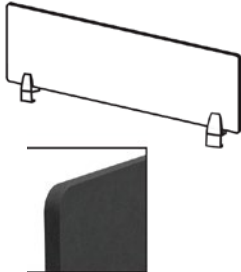

Description:

- Tackable PET Divider .75" thick, radius corners
- .90 NRC rating
- Made from 60% post consumer recycled PE plastic water bottles
- VOC free
- 100% recyclable polyester fiber
- Easily clamps onto surfaces .75" - 1.87"
- Mounting hardware included (silver finish)
- Orders over 50, please check stock

Notes:

- Specify color - "Ash" (SP-18) or "Slate" (SP-33)

Mesa Slide Divider	SD-2424-_____	24"	24"	\$401
---------------------------	---------------	-----	-----	-------

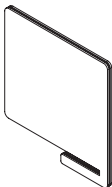

Description:

- Above desk height: 24"
- Tackable PET Divider 1.125" thick, radius corners
- .90 NRC rating
- Made from 60% post consumer recycled PE plastic water bottles
- VOC free
- 100% recyclable polyester fiber
- Easily slides onto surfaces 1.125" thick (1.125" opening for desk)
- Orders over 50, please check stock

Notes:

- Specify color - "Ash" (ASH) or "Slate" (SLATE)

SURFACE MOUNTED DIVIDERS

IN-STOCK

	MODEL	H	W	WEIGHT	LIST PRICE	
	Mesa PET Wrap Divider	WD-4828-__	28"	48"	22 lbs.	\$927
		WD-6028-__	28"	60"	25 lbs.	\$1008
		WD-7228-__ *	28"	72"		\$1,067

Description:

- Above desk height: 24"
- Below desk height: 3" (assuming 1" desk thickness)
- Longest length of side: 23"
- Tackable PET Divider, .75" thick, radius corners
- .90 NRC rating
- Made from 60% post consumer recycled PE plastic water bottles
- VOC free
- 100% recyclable polyester fiber
- Easily clamps onto surfaces .75" - 1.87"
- Orders over 50, please check stock

Notes:

- Specify color - "Iced Grey" (IG) or "Charcoal" (CH)

*** WD-7228-__ is Standard, 8-10 week lead time**

SURFACE MOUNTED DIVIDERS

STANDARD

	MODEL	H	24"W	30"W	36"W	42"W	48"W	54"W	60"W	66"W	72"W
PET Dividers	EDD-PET-__-12	12"	\$393	\$425	\$465	\$499	\$538	\$570	\$596	\$757	\$779
	EDD-PET-__-18	18"	\$450	\$491	\$556	\$580	\$661	\$684	\$709	\$933	\$958
	EDD-PET-__-24	24"	\$507	\$570	\$603	\$716	\$742	\$766	\$798	\$1,135	\$1,160
	EDD-PET-__-30*	30"	\$570	\$603	\$716	\$742	\$854	\$887	\$904	\$1,167	\$1,201



Description:

- Tackable PET Divider .75" thick, radius corners
- .90 NRC rating
- Made from 60% post consumer recycled PE plastic water bottles
- VOC free
- Easily clamps onto surfaces .75" - 1.87"
- Mounting hardware included (silver finish) - 66" W and over ship with 3 clamps

Notes:

- Specify color - Pear, Cobalt, Sandstone, Ash, Slate, Charcoal
- Lead time on orders of 19 or less: 2-3 weeks
- Lead time on orders of 20 or more: 4 weeks

* 30" H dividers available for use ONLY with ADCs (see page 77)

Fabric Fold Dividers

Elements Line (Grade 1 Fabric)

FDD-FF-__-12	12"	\$478	\$528	\$569	\$611	\$639	\$711	\$728	\$929	\$1,000
FDD-FF-__-18	18"	\$589	\$672	\$772	\$822	\$844	\$994	\$1,011	\$1,324	\$1,446
FDD-FF-__-24	24"	\$640	\$732	\$811	\$892	\$922	\$1,056	\$1,080	\$1,386	\$1,526
FDD-FF-__-30*	30"	\$860	\$1,063	\$1,143	\$1,225	\$1,274	\$1,629	\$1,656	\$2,106	\$2,347

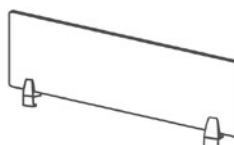

Fusion Line (Grade 2 Fabric)

FDD-FF-__-12	12"	\$508	\$569	\$611	\$660	\$687	\$772	\$787	\$1,000	\$1,082
FDD-FF-__-18	18"	\$649	\$742	\$853	\$945	\$952	\$1,125	\$1,149	\$1,466	\$1,608
FDD-FF-__-24	24"	\$691	\$803	\$892	\$994	\$1,031	\$1,176	\$1,207	\$1,536	\$1,678
FDD-FF-__-30*	30"	\$971	\$1,205	\$1,306	\$1,418	\$1,489	\$1,872	\$1,919	\$2,399	\$2,672

Description:

- Tackable fabric .87" thick, radius corners
- .30 NRC rating
- Grade 1 fabric is 100% post-consumer recycled polyester
- Grade 2 fabric is 74% post-consumer recycled polyester & 26% polyester
- Easily clamps onto surfaces .75" - 1.87"
- Mounting hardware included (silver finish) - 66" W and over ship with 3 clamps



Notes:



- Specify fabric color
- Lead time on orders of 19 or less: 2-3 weeks
- Lead time on orders of 20 or more: 4 weeks

* 30" H dividers available for use ONLY with ADCs (see page 77)

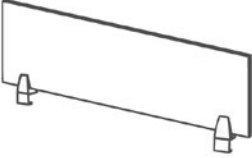
SURFACE MOUNTED DIVIDERS

STANDARD

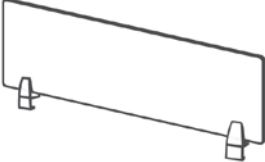
	MODEL	H	24"W	30"W	36"W	42"W	48"W	54"W	60"W	66"W	72"W
 	White Board Dividers										
	WDD-WB-__-12	12"	\$454	\$506	\$548	\$587	\$626	\$789	\$802	\$923	\$968
	WDD-WB-__-18	18"	\$534	\$599	\$715	\$748	\$765	\$1,125	\$1,136	\$1,276	\$1,350
	WDD-WB-__-24	24"	\$600	\$687	\$758	\$856	\$876	\$1,176	\$1,195	\$1,335	\$1,412
	Description:	<ul style="list-style-type: none"> · White board .7" thick, square corners · Easily clamps onto surfaces .75" - 1.87" · Mounting hardware included (silver finish) - 66"W and over ship with 3 clamps 									
	Notes:	<ul style="list-style-type: none"> · Lead time on all orders: 4 weeks 									

 	Mesa Acrylic Dividers										
	ADD-__-12	12"	\$345	\$380	\$401	\$440	\$468	\$487	\$538	\$633	\$660
	ADD-__-18	18"	\$408	\$455	\$500	\$558	\$587	\$650	\$689	\$798	\$856
	ADD-__-24	24"	\$459	\$534	\$565	\$684	\$686	\$715	\$857	\$968	\$969
	Description:	<ul style="list-style-type: none"> · Frosted Acrylic .25" thick, radius corners · Easily clamps onto surfaces .75" - 1.87" · Mounting hardware included (silver finish) - 66"W and over ships with 3 clamps 									
	Notes:	<ul style="list-style-type: none"> · Lead time on all orders: 4+ weeks 									

DIVIDER CLAMPS

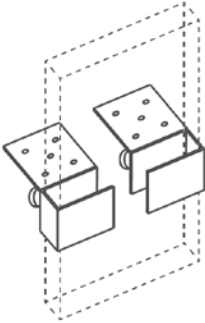
	MODEL	LIST PRICE
 <p>Adjustable Divider Clamps</p>	ADC (1 pair)	\$114
<p>Description:</p> <ul style="list-style-type: none"> · Allows surface mounted dividers to adjust up or down · Mounts to underside of surface · For use with dividers .2" - 1.1" thick · For use with PET & Fabric Fold Dividers · Silver finish · Must be used with surface mounted dividers 30" H <p>Notes:</p> <ul style="list-style-type: none"> · Lead time on orders of 19 or less: 2-3 weeks · Lead time on orders of 20 or more: 4 weeks · Sold with accompanying divider only 		

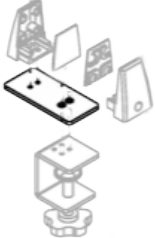
 <p>Offset Bracket Plates</p>	ADC-OSB (1 pair)	No Charge
<p>Description:</p> <ul style="list-style-type: none"> · The offset bracket plate allows for a .5" gap from worksurface to divider, providing extra room for a clamp mounted monitor arm or power module. <p>Notes:</p> <ul style="list-style-type: none"> · Shipped upon request only 		

MODESTY PANELS

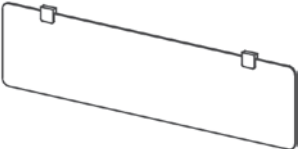
	MODEL	H	24"W	30"W	36"W	42"W	48"W	54"W	60"W	66"W	72"W
 <p>Acrylic Modesty Panel</p>	AMP-__-12	12"	N/A	N/A	\$337	\$378	\$406	\$423	\$475	\$537	\$565
	AMP-__-18	18"	N/A	N/A	\$437	\$495	\$525	\$582	\$627	\$701	\$762
<p>Description:</p> <ul style="list-style-type: none"> · Frosted Acrylic .25" thick, radius corners · Easily mounted under the worksurface · Mounting hardware included (silver finish) <p>Notes:</p> <ul style="list-style-type: none"> · Lead time on all orders: 4+ weeks 											

BEAM MOUNTED DIVIDERS

IN-STOCK

	MODEL	H	W	LIST PRICE
PET Dividers	EDDI-PET-4824-B	24"	48"	\$327
	EDDI-PET-6024-B	24"	60"	\$399

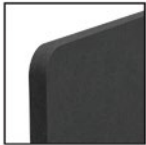

Description:

- Tackable PET Divider .75" thick, radius corners
- .90 NRC rating
- Made from 60% post consumer recycled PE plastic water bottles
- VOC free
- 100% recyclable polyester fiber
- Mounting hardware included (silver finish)



Notes:

- Specify color - "Ash" (SP-18) or "Slate" (SP-33)

BEAM MOUNTED DIVIDERS



STANDARD



	MODEL	H	36"W	42"W	48"W	54"W	60"W	66"W	72"W	
PET Dividers  	HRED-PET-__-12	12"	\$401	\$433	\$474	\$506	\$532	\$692	\$715	
	HRED-PET-__-18	18"	\$492	\$513	\$596	\$619	\$644	\$869	\$893	
	HRED-PET-__-24	24"	\$538	\$652	\$676	\$701	\$734	\$1,071	\$1,095	
Description: <ul style="list-style-type: none"> · Tackable PET Divider .75" thick, radius corners · .90 NRC rating · Made from 60% post consumer recycled PE plastic water bottles · VOC free · 100% recyclable polyester fiber · Mounting hardware included (silver finish) - 66" W and over ships with 3 clamps 										
Notes: <ul style="list-style-type: none"> · Specify color - Pear, Cobalt, Sandstone, Ash, Slate, Charcoal · Lead time on orders of 19 or less: 2-3 weeks · Lead time on orders of 20 or more: 4 weeks 										

Fabric Fold Dividers  	Elements Line (Grade 1 Fabric)									
	MODEL	H	36"W	42"W	48"W	54"W	60"W	66"W	72"W	
	HRFD-FF-__-12	12"	\$511	\$554	\$585	\$655	\$672	\$844	\$915	
	HRFD-FF-__-18	18"	\$715	\$765	\$790	\$937	\$956	\$1,239	\$1,360	
	HRFD-FF-__-24	24"	\$755	\$837	\$868	\$998	\$1,026	\$1,300	\$1,441	
	Fusion Line (Grade 2 Fabric)									
	HRFD-FF-__-12	12"	\$554	\$603	\$633	\$715	\$732	\$915	\$997	
	HRFD-FF-__-18	18"	\$796	\$856	\$897	\$1,070	\$1,093	\$1,380	\$1,485	
	HRFD-FF-__-24	24"	\$837	\$937	\$976	\$1,121	\$1,153	\$1,452	\$1,594	
Description: <ul style="list-style-type: none"> · Tackable fabric, .87" thick, radius corners · .30 NRC rating · Mounting hardware included (silver finish). 66" W and over ships with 3 clamps · Special sizes available: Please contact your sales rep 										
Notes: <ul style="list-style-type: none"> · Specify fabric color · Lead time on orders of 19 or less: 2-3 weeks · Lead time on orders of 20 or more: 4 weeks 										

BEAM MOUNTED DIVIDERS

STANDARD

	MODEL	H	36"W	42"W	48"W	54"W	60"W	66"W	72"W
White Board Dividers  	HRD-WB-__-12	12"	\$485	\$526	\$565	\$729	\$741	\$812	\$876
	HRD-WB-__-18	18"	\$655	\$686	\$705	\$1,063	\$1,075	\$1,183	\$1,259
	HRD-WB-__-24	24"	\$705	\$794	\$814	\$1,115	\$1,134	\$1,241	\$1,319
	Description:	<ul style="list-style-type: none"> · White board .7" thick, square corners · Mounting hardware included (silver finish) - 66" W and over ship with 3 clamps · Special sizes available: Please call your sales rep 							
	Notes:	<ul style="list-style-type: none"> · Lead time on all orders: 4 weeks 							

Mesa Acrylic Dividers  	HRAD-__-12	12"	\$339	\$379	\$408	\$425	\$478	\$539	\$568
	HRAD-__-18	18"	\$439	\$496	\$526	\$583	\$629	\$705	\$764
	HRAD-__-24	24"	\$503	\$624	\$627	\$655	\$797	\$874	\$879
	Description:	<ul style="list-style-type: none"> · Frosted Acrylic .25" thick, radius corners · Mounting hardware included (silver finish) - 66" W and over ships with 3 clamps · Special sizes available: Please call your sales rep 							
	Notes:	<ul style="list-style-type: none"> · Lead time on all orders: 4 weeks 							



AURA® OVERVIEW

SPECIFICATIONS	AURA
Overall Height	23"
Width	46", 58", 70", or 92"
Material	PET
Thickness	9mm (.35")
Edge	Beveled Felt
Environmental	50% from recycled water bottles, Declare Certified
Acoustics	ASTM C 423: NRC [500hz] = .76 NRC [1000hz] = 1
Fire Rating	UL tested ASTM E-84: Class A

XL - 92" X 23"

8 Brackets
\$1,294

L - 70" X 23"

6 Brackets
\$1,238

M - 58" X 23"

5 Brackets
\$827

S - 46" X 23"

4 Brackets
\$664

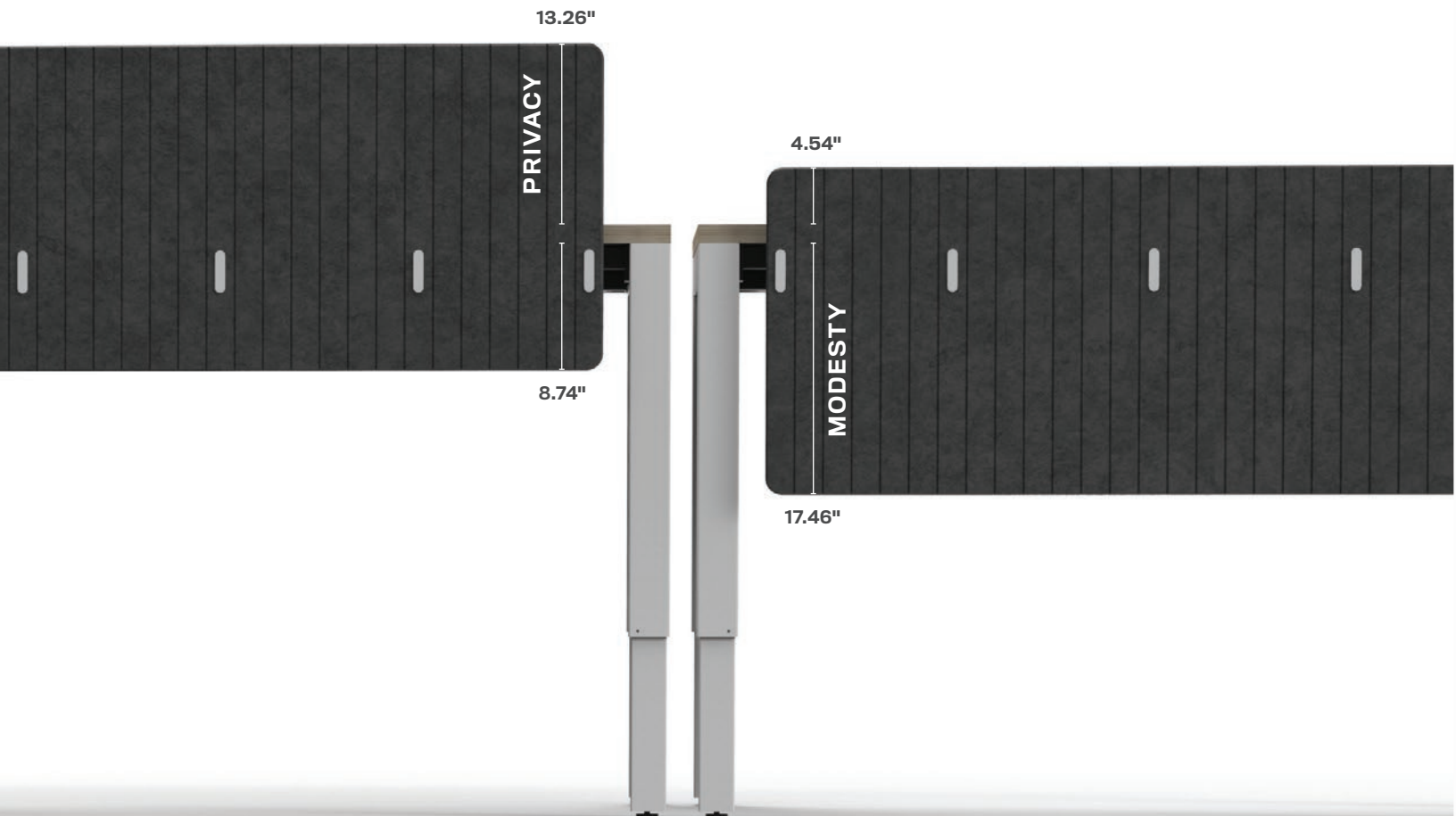

AURA® FINISHES

AURA COLORS



BRACKET FINISHES

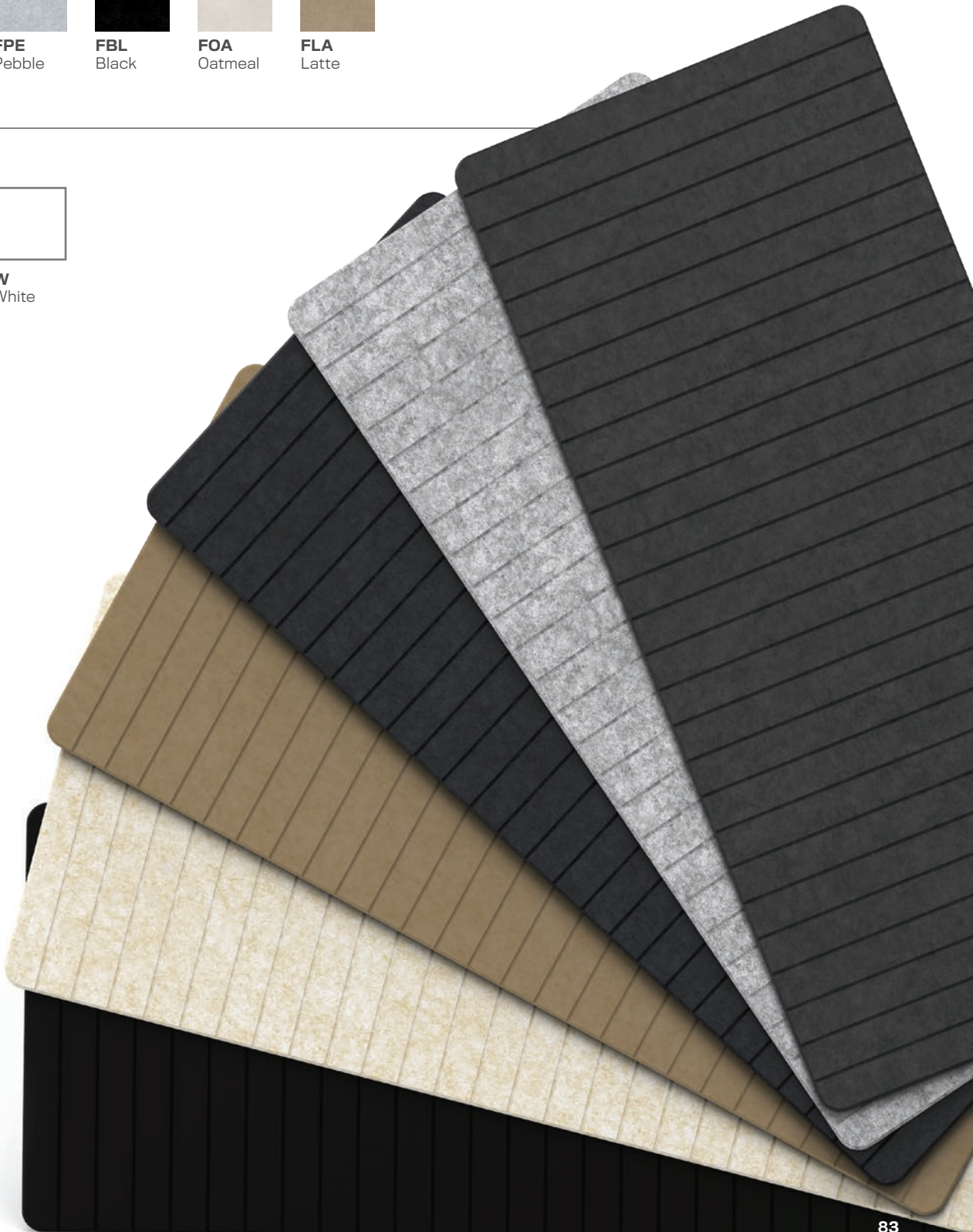

AURA® PRICING

RECTANGULAR WORKSURFACE

LEFT SIDE RETURN / CENTER COVERAGE / RIGHT SIDE RETURN

Dimensions based on 7/8" gap rear with flush on sides

W	D	XL 92" X 23"	L 70" X 23"	M 58" X 23"	S 46" X 23"
48"	30"	21.5" / 48" / 21.5"	10.8" / 48" / 10.8"	4.8" / 48" / 4.8"	46" back edge only
60"	30"	15.5" / 60" / 15.5"	4.8" / 60" / 4.8"	0" / 58.0" / 0"	46" back edge only
72"	30"	9.5" / 72" / 9.5"	0" / 70" / 0"	58" back edge only	46" back edge only
84"	30"	3.5" / 84" / 3.5"	70" back edge only	58" back edge only	46" back edge only
96"	30"	0" / 92" / 0"	70" back edge only	58" back edge only	46" back edge only

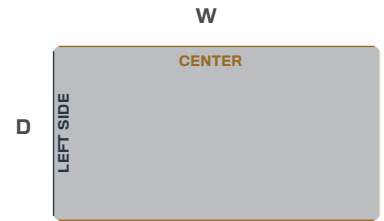

90° WORKSURFACE

LEFT SIDE RETURN / LEFT BACK / RIGHT BACK / RIGHT SIDE RETURN

Dimensions based on 7/8" gap rear with flush on sides

W	D	XL 92" X 23"	L 70" X 23"	M 58" X 23"	S 46" X 23"
36"	30"	10.1" / 36" / 36" / 10.1"	0" / 35" / 35" / 0"	0" / 30" / 30" / 0"	0" / 24" / 24" / 0"
42"	30"	4.1" / 42" / 42" / 4.1"	0" / 35" / 35" / 0"	0" / 30" / 30" / 0"	0" / 24" / 24" / 0"
48"	30"	0" / 46" / 46" / 0"	0" / 35" / 35" / 0"	0" / 30" / 30" / 0"	0" / 24" / 24" / 0"

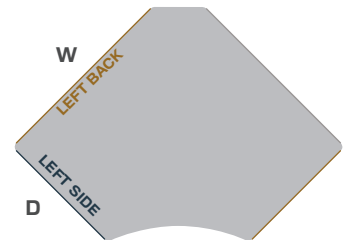

120° WORKSURFACE

LEFT SIDE RETURN / LEFT BACK / RIGHT BACK / RIGHT SIDE RETURN

Dimensions based on 7/8" gap rear with flush on sides

W	D	XL 92" X 23"	L 70" X 23"	M 58" X 23"	S 46" X 23"
36"	30"	9.7" / 36" / 36" / 9.7"	0" / 35" / 35" / 0"	0" / 29" / 29" / 0"	0" / 23" / 23" / 0"
42"	30"	3.7" / 42" / 42" / 3.7"	0" / 35" / 35" / 0"	0" / 29" / 29" / 0"	0" / 23" / 23" / 0"
48"	30"	0" / 46" / 46" / 0"	0" / 35" / 35" / 0"	0" / 29" / 29" / 0"	0" / 23" / 23" / 0"

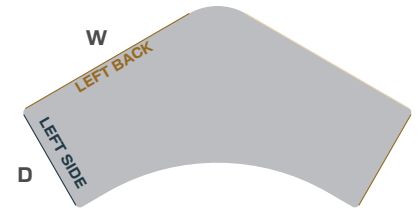

AS2	-	XL	-	FLA	-	8	-	S
NAME		MODEL		COLOR		BLACK BRACKETS		OUTER FASTENERS

Outer fasteners are available in (S) silver or (B) black.



MONITOR ARMS

Our sophisticated monitor arms provide ergonomics, space savings, and clever design. Here, you'll find one-touch adjustment, effortless movement, and sure-footed stability to support a multitude of screen configurations. Reclaim your desktop with our sleek mounting systems that are easy to install.



MONITOR ARMS

STATEMENT OF LINE

MONITOR ARMS



E5 Single Dynamic

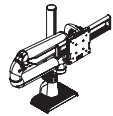

E5 Single Dynamic Pole

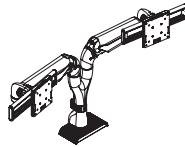

E5 Dual Dynamic

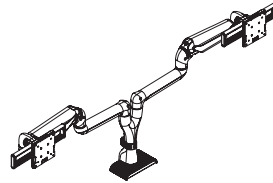

E5 Dual Dynamic Wide

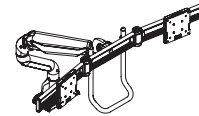

E5 Dual Crossbar Dynamic

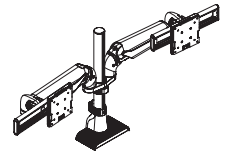

E5 Dual Dynamic Pole

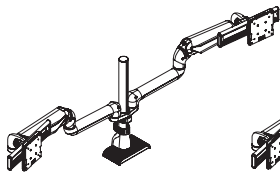

E5 Dual Dynamic Wide Pole

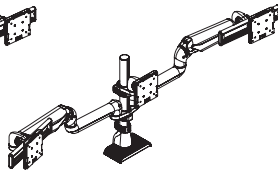

E5 Triple Dynamic Pole



E5 Single Static Pole

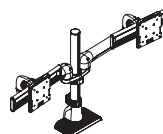

E5 Dual Static Pole

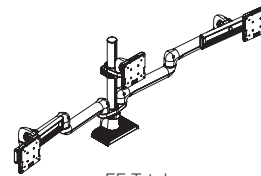

E5 Triple Static Pole

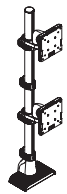

E5 One Over One Static Pole

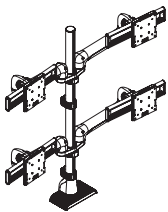

E5 Two Over Two Static Pole

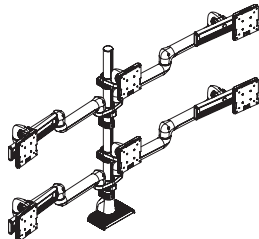

E5 Three Over Three Static Pole

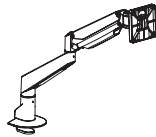

E2 Single

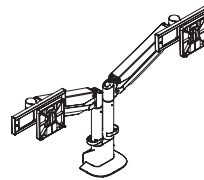

E2 Dual

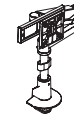

E2 Connex Single Dynamic

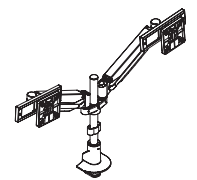

E2 Connex Dual Dynamic

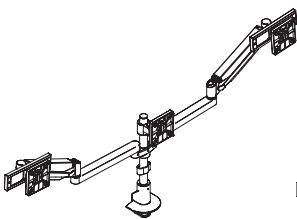

E2 Connex Triple Dynamic

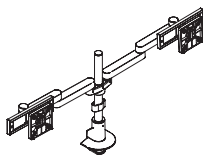

E2 Connex Dual Static

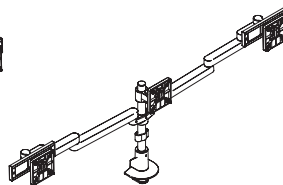

E2 Connex Triple Static



E2 Connex One Over One

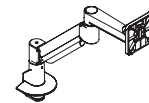

7000 Single

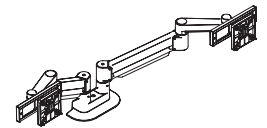

7000 Dual

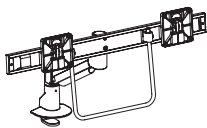

7000 Dual Crossbar

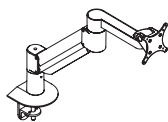

7500

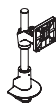

Staxx Single Static

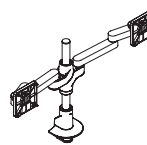

Staxx Dual Static

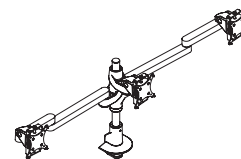

Staxx Static Triple

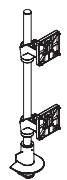

Staxx Static One Over One

MONITOR ARMS

STATEMENT OF LINE

MONITOR ARMS

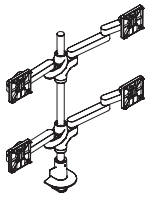

Staxx Two Over Two Static

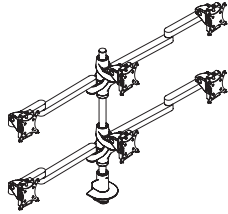

Staxx Three Over Three Static

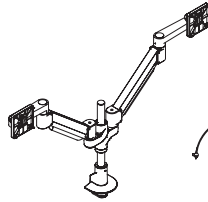

Staxx Dual Dynamic

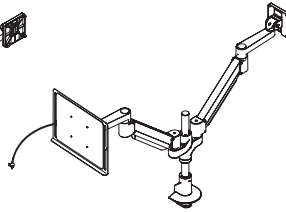

Staxx Dual Dynamic w/Laptop Tray

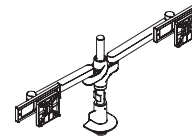

Staxx Dual Static w/Sliders

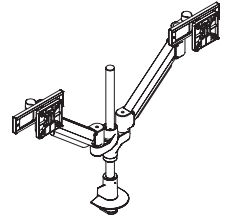

Staxx Dual Dynamic w/Sliders

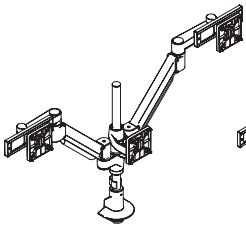

Staxx Triple Dynamic w/Sliders

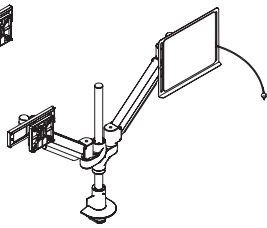

Staxx Dual Dynamic w/Laptop Tray and Slider

MOUNTS & ACCESSORIES

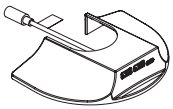

Single Charging Cap

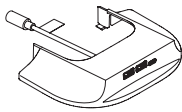

Dual Charging Cap

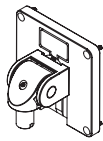

Next Gen Tilter

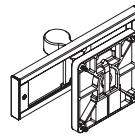

Slider

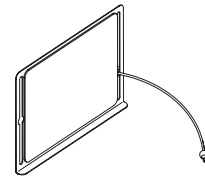

Laptop Tray

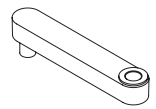

Articulating Extension Arms

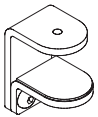

Flexmount Conversion Kit for Top Down Mount

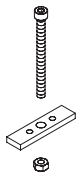

Thru-Desk Conversion Kit for Top Down Mount

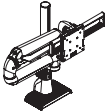
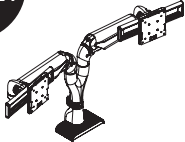
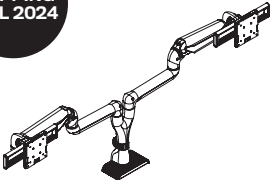
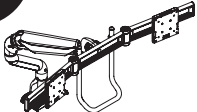
	MODEL	WEIGHT CAPACITY	SCREEN SIZE	LIST PRICE
	E5-D1L-__	0-25 lbs.	Up to 49"	\$365
	E5-D1-__	5-45 lbs.	Up to 49"	\$560
	E5-P01SD-__	0-25 lbs.	Up to 49"	\$580
	E5-D2-__	0-25 lbs. per monitor	Up to 32"	\$665
	E5-D2SD-__	0-20 lbs. per monitor	Up to 44" bezel measured	\$950
	E5-D2C-__	0-20 lbs. per monitor	Up to 27"	\$877

SHIPPING
FALL 2024SHIPPING
FALL 2024SHIPPING
FALL 2024SHIPPING
FALL 2024SHIPPING
FALL 2024**Description:**

- Mounting: Top down desk mount: clamps to desk edge or grommet, desk thickness up to 1.5", 2.25" minimum grommet hole diameter

Notes:

- **Specify color:** Black (BLK) Silver (SLV) White (WHT) Polished Aluminum (PWH)*

Description:

- Mounting: Top down desk mount: clamps to desk edge or grommet, desk thickness up to 1.5", 2.25" minimum grommet hole diameter

Notes:

- **Specify color:** Black (BLK) Silver (SLV) White (WHT) Polished Aluminum (PWH)*

Description:

- Mounting: Top down desk mount: clamps to desk edge or grommet, desk thickness up to 1.5", 2.25" minimum grommet hole diameter

Notes:

- **Specify color:** Black (BLK) Silver (SLV) White (WHT) Polished Aluminum (PWH)*

Description:

- Mounting: Top down desk mount: clamps to desk edge or grommet, desk thickness up to 1.5", 2.25" minimum grommet hole diameter

Notes:

- **Specify color:** Black (BLK) Silver (SLV) White (WHT) Polished Aluminum (PWH)*

Description:

- Mounting: Top down desk mount: clamps to desk edge or grommet, desk thickness up to 1.5", 2.25" minimum grommet hole diameter

Notes:

- **Specify color:** Black (BLK) Silver (SLV) White (WHT) Polished Aluminum (PWH)*

* Polished Aluminum finish incurs an upcharge, contact your rep for pricing.

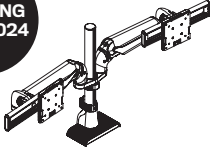
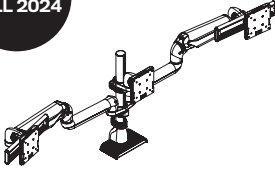
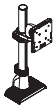
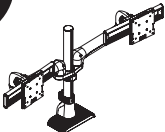
	MODEL	WEIGHT CAPACITY	SCREEN SIZE	LIST PRICE
 <p>SHIPPING FALL 2024</p>	E5-P02D-___	0-25 lbs. per monitor	Up to 32"	\$780
	<p>Description:</p> <ul style="list-style-type: none"> · Mounting: Top down desk mount: clamps to desk edge or grommet, desk thickness up to 1.5", 2.25" minimum grommet hole diameter <p>Notes:</p> <ul style="list-style-type: none"> · Specify color: Black (BLK) Silver (SLV) White (WHT) Polished Aluminum (PWH)* 			
 <p>SHIPPING FALL 2024</p>	E5-P02SD-___	0-20 lbs. per monitor	Up to 44" bezel measured	\$990
	<p>Description:</p> <ul style="list-style-type: none"> · Mounting: Top down desk mount: clamps to desk edge or grommet, desk thickness up to 1.5", 2.25" minimum grommet hole diameter <p>Notes:</p> <ul style="list-style-type: none"> · Specify color: Black (BLK) Silver (SLV) White (WHT) Polished Aluminum (PWH)* 			
 <p>SHIPPING FALL 2024</p>	E5-P03SD-___	0-20 lbs. per monitor	Up to 27"	\$1,236
	<p>Description:</p> <ul style="list-style-type: none"> · Mounting: Top down desk mount: clamps to desk edge or grommet, desk thickness up to 1.5", 2.25" minimum grommet hole diameter <p>Notes:</p> <ul style="list-style-type: none"> · Specify color: Black (BLK) Silver (SLV) White (WHT) Polished Aluminum (PWH)* 			
 <p>SHIPPING FALL 2024</p>	E5-P01-___	0-45 lbs.	Up to 49"	\$336
	<p>Description:</p> <ul style="list-style-type: none"> · Mounting: Top down desk mount: clamps to desk edge or grommet, desk thickness up to 1.5", 2.25" minimum grommet hole diameter <p>Notes:</p> <ul style="list-style-type: none"> · Specify color: Black (BLK) Silver (SLV) White (WHT) Polished Aluminum (PWH)* 			
 <p>SHIPPING FALL 2024</p>	E5-P02S-___	0-25 lbs. per monitor	Up to 27"	\$622
	<p>Description:</p> <ul style="list-style-type: none"> · Mounting: Top down desk mount: clamps to desk edge or grommet, desk thickness up to 1.5", 2.25" minimum grommet hole diameter <p>Notes:</p> <ul style="list-style-type: none"> · Specify color: Black (BLK) Silver (SLV) White (WHT) Polished Aluminum (PWH)* 			

* Polished Aluminum finish incurs an upcharge, contact your rep for pricing.

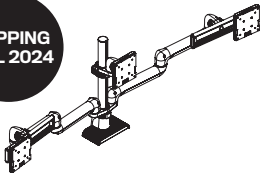
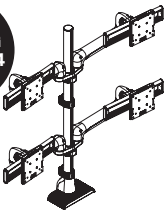
	MODEL	WEIGHT CAPACITY	SCREEN SIZE	LIST PRICE
 <p>E5 Triple Static Pole</p> <p>SHIPPING FALL 2024</p>	E5-P03SS-___	0-20 lbs. per monitor	Up to 27"	\$1,069
<p>Description:</p> <ul style="list-style-type: none"> · Mounting: Top down desk mount: clamps to desk edge or grommet, desk thickness up to 1.5", 2.25" minimum grommet hole diameter <p>Notes:</p> <ul style="list-style-type: none"> · Specify color: Black (BLK) Silver (SLV) White (WHT) Polished Aluminum (PWH)* 				
 <p>E5 One Over One Static Pole</p> <p>SHIPPING FALL 2024</p>	E5-P11-___	0-30 lbs. per monitor	Up to 49"	\$553
<p>Description:</p> <ul style="list-style-type: none"> · Mounting: Top down desk mount: clamps to desk edge or grommet, desk thickness up to 1.5", 2.25" minimum grommet hole diameter <p>Notes:</p> <ul style="list-style-type: none"> · Specify color: Black (BLK) Silver (SLV) White (WHT) Polished Aluminum (PWH)* 				
 <p>E5 Two Over Two Static Pole</p> <p>SHIPPING FALL 2024</p>	E5-P22S-___	0-15 lbs. per monitor	Up to 27"	\$1,621
<p>Description:</p> <ul style="list-style-type: none"> · Mounting: Top down desk mount: clamps to desk edge or grommet, desk thickness up to 1.5", 2.25" minimum grommet hole diameter <p>Notes:</p> <ul style="list-style-type: none"> · Specify color: Black (BLK) Silver (SLV) White (WHT) Polished Aluminum (PWH)* 				
 <p>E5 Three Over Three Static Pole</p> <p>SHIPPING FALL 2024</p>	E5-P33SS-___	0-10 lbs. per monitor	Up to 27"	\$2,021
<p>Description:</p> <ul style="list-style-type: none"> · Mounting: Top down desk mount: clamps to desk edge or grommet, desk thickness up to 1.5", 2.25" minimum grommet hole diameter <p>Notes:</p> <ul style="list-style-type: none"> · Specify color: Black (BLK) Silver (SLV) White (WHT) Polished Aluminum (PWH)* 				

* Polished Aluminum finish incurs an upcharge, contact your rep for pricing.

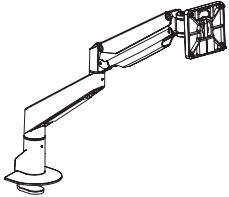
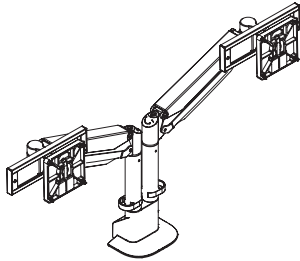
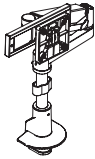
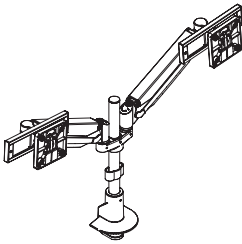
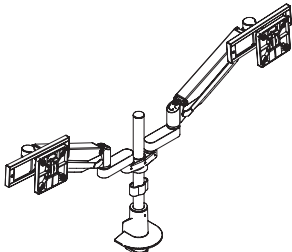
	MODEL	WEIGHT CAPACITY	SCREEN SIZE	LIST PRICE
	E2 Single E2-1-___	Flat panel: 2.2 - 20 lbs. Curved monitor: Up to 16 lbs.	Based on weight	\$322
	<p>Description:</p> <ul style="list-style-type: none"> · Mounting: Top down desk mount: clamps to desk edge or grommet, desk thickness up to 1.5" · Height adjustment: 13.3" · Extension range: 23.7" <p>Notes:</p> <ul style="list-style-type: none"> · Specify color: Black (104) Silver (124) White (248) 			
	E2 Dual E2-2-___	Flat panel: 2.2 - 20 lbs. Curved monitor: Up to 16 lbs.	Up to 27"	\$598
	<p>Description:</p> <ul style="list-style-type: none"> · Mounting: Top down desk mount: clamps to desk edge, desk thickness up to 1.5" · Height adjustment: 13" · Extension range: 17.5" - 28.5" side-by-side <p>Notes:</p> <ul style="list-style-type: none"> · Specify color: Black (104) Silver (124) White (248) 			
	E2 Connex Single E2-01-SD-___	Flat panel: 2.2 - 20 lbs. Curved monitor: Up to 16 lbs.	Any size within weight capacity	\$475
	<p>Description:</p> <ul style="list-style-type: none"> · Mounting: Top down desk mount: clamps to desk edge or grommet, desk thickness up to 1.5" <p>Notes:</p> <ul style="list-style-type: none"> · Specify color: Black (104) Silver (124) White (248) 			
	E2 Connex Dynamic Dual E2-02-D-___	2.2 - 20 lbs. per monitor	Up to 32" (bezel measured left to right)	\$839
	<p>Description:</p> <ul style="list-style-type: none"> · Mounting: Top down desk mount: clamps to desk edge or grommet, desk thickness up to 1.5" <p>Notes:</p> <ul style="list-style-type: none"> · Specify color: Black (104) Silver (124) White (248) 			
	E2 Connex Dynamic Dual Wide E2-02-SD-___	2.2 - 20 lbs. per monitor	Up to 39" (bezel measured left to right)	\$964
	<p>Description:</p> <ul style="list-style-type: none"> · Mounting: Top down desk mount: clamps to desk edge or grommet, desk thickness up to 1.5" <p>Notes:</p> <ul style="list-style-type: none"> · Specify color: Black (104) Silver (124) White (248) 			

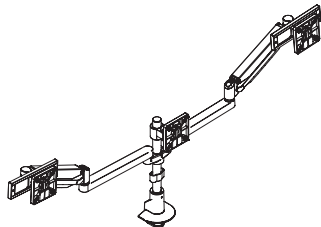
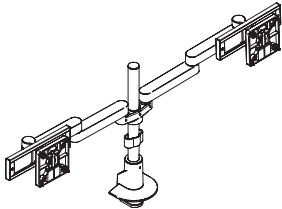
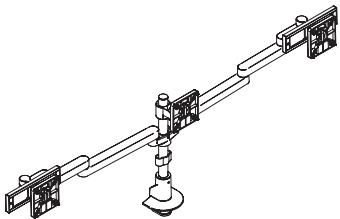
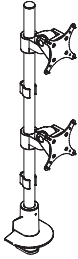
	MODEL	WEIGHT CAPACITY	SCREEN SIZE	LIST PRICE
E2 Connex Dynamic Triple	E2-03-SD-___	2.2 - 20 lbs. per monitor	Up to 28.5" (bezel measured left to right)	\$1,082
	Description: · Mounting: Top down desk mount: clamps to desk edge or grommet, desk thickness up to 1.5"	Notes: · Specify color: Black (104) Silver (124) White (248)		
E2 Connex Static Dual	E2-02-SS-___	2.2 - 20 lbs. per monitor	Up to 37" (bezel measured left to right)	\$724
	Description: · Mounting: Top down desk mount: clamps to desk edge or grommet, desk thickness up to 1.5"	Notes: · Specify color: Black (104) Silver (124) White (248)		
E2 Connex Static Triple	E2-03-SSS-___	2.2 - 20 lbs. per monitor	Up to 27.5" (bezel measured left to right)	\$852
	Description: · Mounting: Top down desk mount: clamps to desk edge or grommet, desk thickness up to 1.5"	Notes: · Specify color: Black (104) Silver (124) White (248)		
E2 Connex One Over One	E2-11-HD-___	See description	See description	\$334
	Description: · Mounting: Top down desk mount: clamps to desk edge or grommet, desk thickness up to 1.5" · Weight capacity: Flat Panel Monitors: Up to 40 lbs. per monitor Curved Monitors: 0 - 26.5 lbs. per monitor · Screen size: One Flat Panel Monitor: Up to 43" (16:9 aspect ratio) Two Flat Panel Monitors: Up to 49" (21:9 aspect ratio) Two Curved Monitors: Up to 49" (21:9 aspect ratio)	Notes: · Specify color: Black (104) Silver (124) White (248)		

MONITOR ARMS

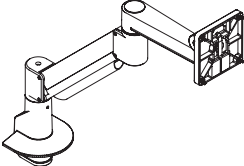
	MODEL	WEIGHT CAPACITY	SCREEN SIZE	LIST PRICE
	7000-500-___	Flat panel: 3 - 10lbs. Curved monitor: Up to 10 lbs	Based on weight	\$410
	7000-800-___	Flat Panel: 10 - 22 lbs. Curved monitor: Up to 22 lbs	Based on weight	\$410
	7000-1000-___	Flat Panel: 13 - 28 lbs. Curved monitor: Up to 22 lbs	Based on weight	\$410
	7000-1000-HD-___	Flat Curved: 13 - 28 lbs	Based on weight	\$479

Description:

- Mounting: Top down desk mount: clamps to desk edge or grommet, desk thickness up to 1.5"
- Height adjustment: 16"
- Extension range: 24"

Notes:

- **Specify color:** Black (104) Silver (124) White (248)

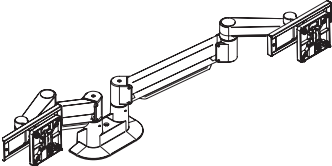
	7000-2-500-SLD-___	3 - 10 lbs. per monitor	Up to 32"	\$800
	7000-2-800-SLD-___	10 - 22 lbs. per monitor	Up to 32"	\$800

Description:

- Mounting: Top down: desk clamp, grommet mount
- Height adjustment: 16"
- Extension range: 24"

Notes:

- **Specify color:** Black (104) Silver (124) White (248)

	7000-1-8537H-___	6 - 14 lbs. per monitor	Up to 27"	\$562
-------------------------------------------------------------------------------------	------------------	-------------------------	-----------	-------

Description:

- Mounting: Top down desk mount: clamps to desk edge or grommet, desk thickness up to 1.5"

Notes:

- **Specify color:** Black (104) Silver (124) White (248)

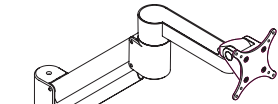
	7500-500-___	2 - 13 lbs.	Up to 43"	\$626
	7500-800-___	6 - 21 lbs.	Up to 43"	\$626
	7500-1000-___	8 - 27 lbs.	Up to 43"	\$626
	7500-1500-___	12 - 40 lbs.	Up to 43"	\$626

Description:

- Mounting: Desk edge, thru-desk, grommet, wall, reverse wall, side bolt
- Height adjustment: 18"
- Extension range: 27"

Notes:

- **Specify color:** Black (104) Silver (124) White (248)

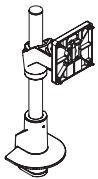
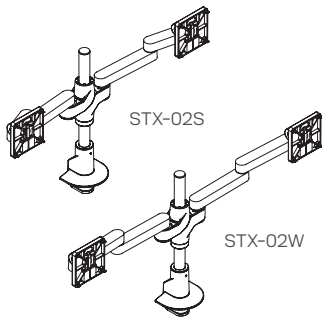
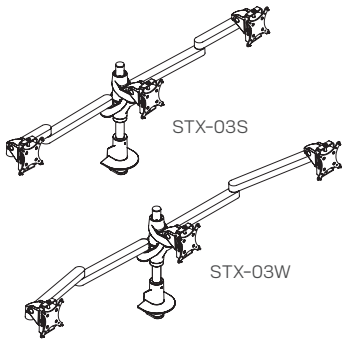
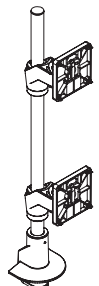
	MODEL	WEIGHT CAPACITY	SCREEN SIZE	LIST PRICE
Staxx Single 	STX-01S-___	1 - 30 lbs.	Up to 50"	\$298
	Description: · Mounting: Top down desk mount: clamps to desk edge or grommet, desk thickness up to 1.5" Notes: · Specify color: Black (104) Silver (124) White (248)			
Staxx Dual 	STX-02S-___	1 - 20 lbs. per monitor	Up to 24"	\$678
	STX-02W-___	1 - 20 lbs. per monitor	24" - 30"	\$748
Description: · Mounting: Top down desk mount: clamps to desk edge or grommet, desk thickness up to 1.5" Notes: · Specify color: Black (104) Silver (124) White (248)				
Staxx Triple 	STX-03S-___	1 - 15 lbs. per monitor	Up to 24"	\$807
	STX-03W-___	1 - 15 lbs. per monitor	24" - 30"	\$860
Description: · Mounting: Top down desk mount: clamps to desk edge or grommet, desk thickness up to 1.5" Notes: · Specify color: Black (104) Silver (124) White (248)				
Staxx 1 Over 1 	STX-11S-___	1 - 20 lbs. per monitor	Up to 30"	\$782
	Description: · Mounting: Top down desk mount: clamps to desk edge or grommet, desk thickness up to 1.5" Notes: · Specify color: Black (104) Silver (124) White (248)			

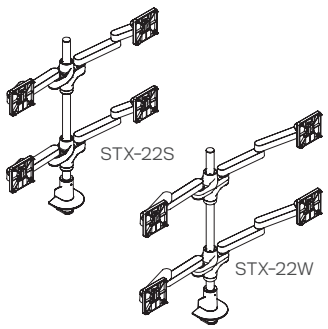
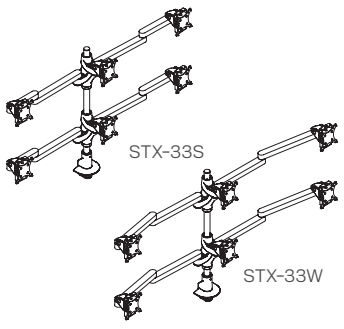
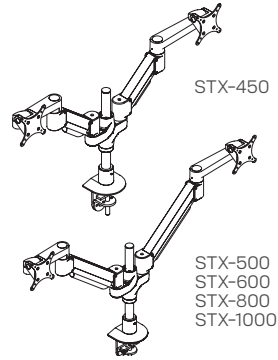
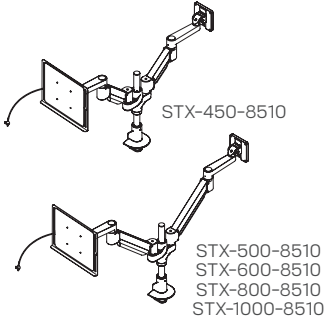
	MODEL	WEIGHT CAPACITY	SCREEN SIZE	LIST PRICE
Staxx 2 Over 2 	STX-22S-___	1 - 15 lbs. per monitor	Up to 24"	\$938
	STX-22W-___	1 - 15 lbs. per monitor	24" - 30"	\$971
Description: · Mounting: Top down desk mount: clamps to desk edge or grommet, desk thickness up to 1.5"				
Notes: · Specify color: Black (104) Silver (124) White (248)				
Staxx 3 Over 3 	STX-33S-___	1 - 10 lbs. per monitor	Up to 24"	\$1,358
	STX-33W-___	1 - 10 lbs. per monitor	24" - 30"	\$1,410
Description: · Mounting: Top down desk mount: clamps to desk edge or grommet, desk thickness up to 1.5"				
Notes: · Specify color: Black (104) Silver (124) White (248)				
Staxx Dual Articulating 	STX-450-___	10 - 23 lbs. per monitor	Up to 27"	\$884
	STX-500-___	3 - 10 lbs. per monitor	Up to 27"	\$884
	STX-600-___	7 - 17 lbs. per monitor	Up to 27"	\$884
	STX-800-___	10 - 22 lbs. per monitor	Up to 27"	\$884
	STX-1000-___	13 - 28 lbs. per monitor	Up to 27"	\$884
Description: · Mounting: Top down desk mount: clamps to desk edge or grommet, desk thickness up to 1.5"				
Notes: · Specify color: Black (104) Silver (124) White (248)				
Staxx Dual Articulating 	STX-450-8510-___	10 - 23 lbs. per monitor	Up to 27"	\$1,068
	STX-500-8510-___	3-10 lbs. per monitor	Up to 27"	\$1,068
	STX-600-8510-___	7 - 17 lbs. per monitor	Up to 27"	\$1,068
	STX-800-8510-___	10 - --22 lbs. per monitor	Up to 27"	\$1,068
	STX-1000-8510-___	13 - 28 lbs. per monitor	Up to 27"	\$1,068
Description: · Supports 3 - 13.5 lb laptop · Mounting: Top down desk mount: clamps to desk edge or grommet, desk thickness up to 1.5"				
Notes: · Specify color: Black (104) Silver (124) White (248)				

	MODEL	WEIGHT CAPACITY	SCREEN SIZE	LIST PRICE
Staxx Dual w/Sliders	STX-02-SLD-___	20 lbs. per monitor	Up to 27"	\$510

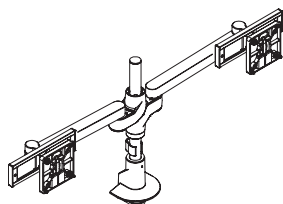

Description:

· Mounting: Top down desk mount: clamps to desk edge or grommet, desk thickness up to 1.5"

Notes:

· **Specify color:** Black (104) Silver (124) White (248)

Staxx Dual Articulating w/Sliders	STX-2-500-SLD-___ STX-2-800-SLD-___	3-10 lbs. per monitor 20 lbs. per monitor	Up to 27" Up to 27"	\$877 \$877
------------------------------------------	----------------------------------------	----------------------------------------------	------------------------	----------------

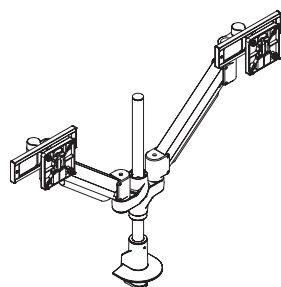

Description:

· Mounting: Top down desk mount: clamps to desk edge or grommet, desk thickness up to 1.5"

Notes:

· **Specify color:** Black (104) Silver (124) White (248)

Staxx Triple w/Sliders	STX-3S-500-SLD-___ STX-3S-800-SLD-___	3-10 lbs. per monitor 20 lb. per monitor	Up to 27" Up to 27"	\$1,025 \$1,025
-------------------------------	------------------------------------------	---------------------------------------------	------------------------	--------------------

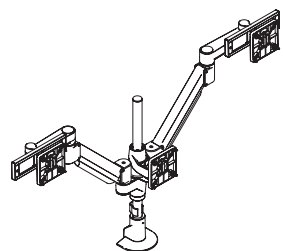

Description:

· Mounting: Top down desk mount: clamps to desk edge or grommet, desk thickness up to 1.5"

Notes:

· **Specify color:** Black (104) Silver (124) White (248)

Staxx Dual Laptop w/Slider	STX-2-500-8510-___ STX-2-800-8510-___	3 - 10 lbs. per monitor 20 lbs. per monitor	Up to 27" Up to 27"	\$1,007 \$1,007
-----------------------------------	------------------------------------------	------------------------------------------------	------------------------	--------------------

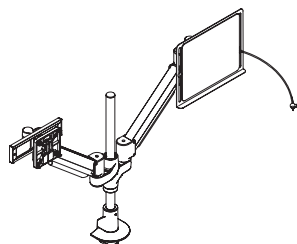

Description:

· Mounting: Top down desk mount: clamps to desk edge or grommet, desk thickness up to 1.5"

Notes:

· **Specify color:** Black (104) Silver (124) White (248)

STORAGE

Stay organized and keep your belongings secure with HAT storage units. Our mobile pedestals are heavy-duty, lockable, and comfortably accommodate your office supplies. Slide your mobile storage unit underneath your worksurface for easy, out-of-the-way access.



STORAGE

STATEMENT OF LINE

STORAGE



HAT Mobile Pedestal Slim
(10.6")

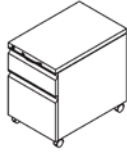

HAT Mobile Pedestal
(15")

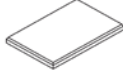

HAT Pedestal Cushions

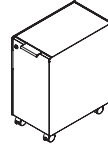

Collective Storage
Mobile Locker



Collective Storage
Mobile Pedestal Slim (12")

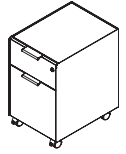

Collective Storage
Mobile Pedestal (15")

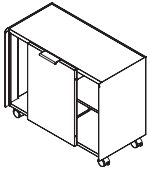

Collective Storage
Mobile Credenza (30")

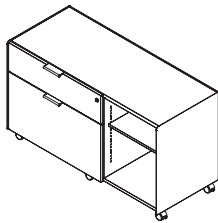

Collective Storage
Mobile Credenza (48")

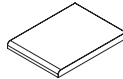

Collective Storage
Cushions

STORAGE

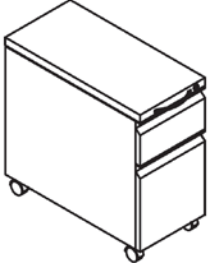
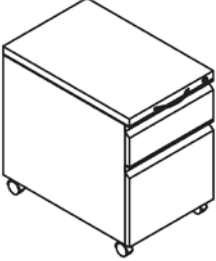
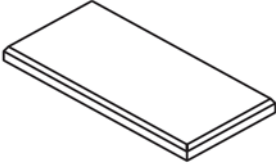
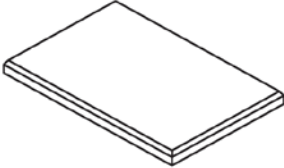
	MODEL	WIDTH	DEPTH	HEIGHT	WEIGHT	LIST PRICE
HAT Mobile Pedestal Slim	MPEDBF-10-__	10.6"	22"	21"	55 lbs.	\$623
	Description: <ul style="list-style-type: none"> · Mobile Box/File Pedestal · Includes lock and key · Includes pencil tray · Letter or legal filing · Includes casters (2 locking, 2 non-locking) · Stocked in silver, white and black Notes: <ul style="list-style-type: none"> · Key alike available (add \$10 to list) · Master/Core Key available (add \$10 to list) 					
HAT Mobile Pedestal	MPEDBF-15-__	15"	22"	21"	65 lbs.	\$623
	Description: <ul style="list-style-type: none"> · Mobile Box/File Pedestal · Includes lock and key · Includes pencil tray · Letter or legal filing · Includes casters (2 locking, 2 non-locking) · Stocked in silver, white and black Notes: <ul style="list-style-type: none"> · Key alike available (add \$10 to list) · Master/Core Key available (add \$10 to list) 					
HAT Pedestal Slim Cushion	MPEDCUS-10 (in-stock) MPEDCUS-10 (standard)	10.6" 10.6"	22" 22"	1.5" 1.5"	5 lbs. 5 lbs.	\$132 \$138
	Description: <ul style="list-style-type: none"> · Pedestal seat cushion · High density foam · Laminated plywood understructure · Attached with velcro · Stocked in #15-13 charcoal fabric Notes: <ul style="list-style-type: none"> · Other colors available: 8 week lead time · 50 QTY minimum order for non-stocked colors 					
HAT Pedestal Cushion	MPEDCUS-15 (in-stock) MPEDCUS-15 (standard)	15" 15"	22" 22"	1.5" 1.5"	6 lbs. 6 lbs.	\$132 \$138
	Description: <ul style="list-style-type: none"> · Pedestal seat cushion · High density foam · Laminated plywood understructure · Attached with velcro · Stocked in #15-13 charcoal fabric Notes: <ul style="list-style-type: none"> · Other colors available: 8 week lead time · 50 QTY minimum order for non-stocked colors 					

Please specify color:

SI = Silver, WH = White, BK = Black

Add code to end of model number.

Example: MPEDBF-15-SI

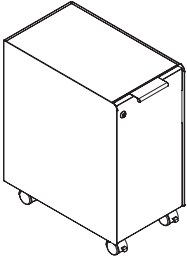
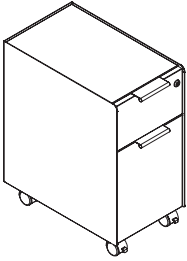
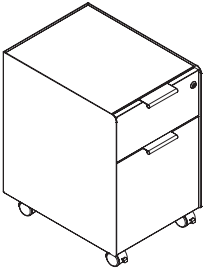
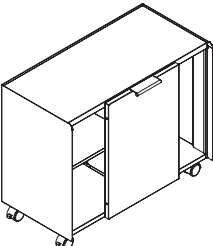
	MODEL	WIDTH	DEPTH	HEIGHT	WEIGHT	LIST PRICE
Collective Storage Mobile Locker 	STG-LKR-12-__	12"	20"	24"	35 lbs.	\$864
	Description: <ul style="list-style-type: none"> · Mobile locker · Includes lock and key · Includes pencil tray · Letter or legal filing · Includes casters (2 locking, 2 non-locking) and anti-tipping counterweight · Available in silver, white and black Notes: <ul style="list-style-type: none"> · 25 QTY minimum order 					
Collective Storage Mobile Pedestal Slim 	STG-PED-12-__	12"	20"	24"	62 lbs.	\$974
	Description: <ul style="list-style-type: none"> · Mobile box/file pedestal · Includes lock and key · Includes pencil tray · Letter or legal filing · Includes casters (2 locking, 2 non-locking) and anti-tipping counterweight · Available in silver, white and black Notes: <ul style="list-style-type: none"> · 25 QTY minimum order 					
Collective Storage Mobile Pedestal 	STG-PED-15-__	15"	20"	24"	69 lbs.	\$1,017
	Description: <ul style="list-style-type: none"> · Mobile box/file pedestal · Includes lock and key · Includes pencil tray · Letter or legal filing · Includes casters (2 locking, 2 non-locking) and anti-tipping counterweight · Available in silver, white and black Notes: <ul style="list-style-type: none"> · 25 QTY minimum order 					
Collective Storage Mobile Credenza (30") 	STG-CRD-30-__	30"	15"	24"	53 lbs.	\$1,413
	Description: <ul style="list-style-type: none"> · Mobile credenza · Includes shelving and sliding door · Includes casters (2 locking, 2 non-locking) · Available in silver, white and black Notes: <ul style="list-style-type: none"> · 25 QTY minimum order 					

Please specify color:

SI = Silver, WH = White, BK = Black

Add code to end of model number.

Example: STG-PED-15-SI

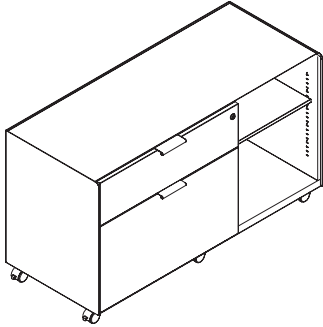
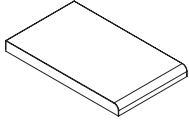
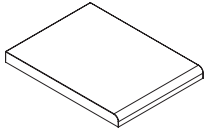
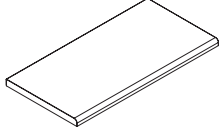
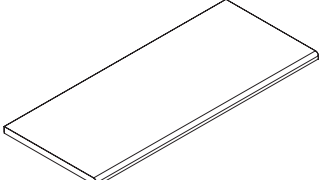
	MODEL	WIDTH	DEPTH	HEIGHT	WEIGHT	LIST PRICE
Collective Storage Mobile Credenza (48") 	STG-CRD-48-__	48"	20"	27"	117 lbs.	\$2,590
	Description: <ul style="list-style-type: none"> · Includes shelving and 2 drawers · Includes lock and key · Includes casters (2 locking, 4 non-locking) · Available in silver, white and black 					
	Notes: <ul style="list-style-type: none"> · 25 QTY minimum order 					
Collective Storage Locker/Pedestal Slim Cushion (12") 	STG-CUS-12-__-__	12"	20"	1.5"	3 lbs.	\$190
	Description: <ul style="list-style-type: none"> · Locker/pedestal seat cushion · High density foam · Attached with velcro 					
	Notes: <ul style="list-style-type: none"> · 25 QTY minimum order 					
Collective Storage Pedestal Cushion (15") 	STG-CUS-15-__-__	15"	20"	1.5"	4 lbs.	\$215
	Description: <ul style="list-style-type: none"> · Pedestal seat cushion · High density foam · Attached with velcro 					
	Notes: <ul style="list-style-type: none"> · 25 QTY minimum order 					
Collective Storage Credenza Cushion (30") 	STG-CUS-30-__-__	30"	15"	1.5"	6 lbs.	\$222
	Description: <ul style="list-style-type: none"> · Credenza seat cushion · High density foam · Attached with velcro 					
	Notes: <ul style="list-style-type: none"> · 25 QTY minimum order 					
Collective Storage Credenza Cushion (48") 	STG-CUS-48-__-__	48"	20"	1.5"	12 lbs.	\$425
	Description: <ul style="list-style-type: none"> · Credenza seat cushion · High density foam · Attached with velcro 					
	Notes: <ul style="list-style-type: none"> · 25 QTY minimum order 					

Please specify color:
SI = Silver, WH = White, BK = Black

Add code to end of model number.
Example: STG-PED-15-SI



SEATING

HAT Collective offers everything you need to work your way, including our original ergonomic seating solution. Every body is different. Our HAT Collective seating adapts to an individual's natural movement making for a fluid and supportive experience.

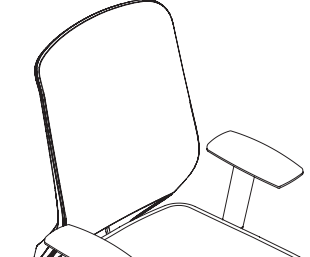

IKU	MODEL	LIST PRICE
	IKU-B-M1H-JET-S1BB	\$945
	IKU-B-M2H-IRON-S1BB	\$945
	IKU-B-M3H-ALLOY-S1BB	\$945
	IKU-B-M1H-JET-S1PB	\$1,185
	IKU-B-M2H-IRON-S1PB	\$1,185
	IKU-B-M3H-ALLOY-S1PB	\$1,185
	IKU-W-M1H-JET-S1PB	\$1,339
	IKU-W-M2H-IRON-S1PB	\$1,339
	IKU-W-M3H-ALLOY-S1PB	\$1,339

Description:

Weight Range: 300 lbs

Armrest Adjustment Range: 7.5" - 10.5" (top of armrest to top of seat pan)

Armrests Lock: 11 increment positions

Black Nylon Base: 16.8" - 20.5"

Polished Aluminum Base: 16.2" - 19.9"

Seatback Adjustment Range: 95° - 129°, 4 position back lock

Seat Depth Adjustment: 2.3"

Notes:

- **Frame:** Black (B), White (W)

- **Mesh:** Raven (M1H), Smoke (M2H), Cloud (M3H)



- **Seat Upholstery:** Jet (JET), Alloy (ALLOY), Iron (IRON)

- **Base:** Black Nylon (S1BB), Polished Aluminum (S1PB)

ACCESSORIES

Our collection of accessories ensures you get the most out of your workspace. Manage and organize wires, mobilize your keyboard, or mount your CPU. We have everything you need to complete your desk, personalizing your workstation to function for you.

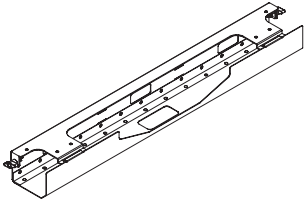
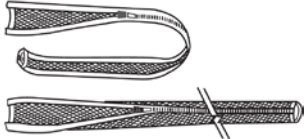
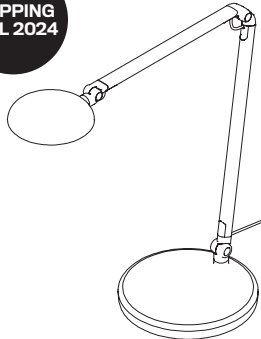

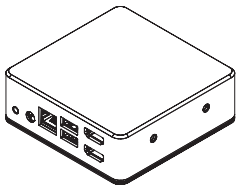
	MODEL	WEIGHT	LIST PRICE
Wire Management Trough 	WMT-SI	6 lbs.	\$198
	Description: <ul style="list-style-type: none"> · Large capacity supports multiple wires, cables and a power strip · Multiple cable pass through ports offers versatile cable management · Trough hinges open, allowing for easy access and installation · Heavy-duty steel construction · 30" W x 3" H x 4" D · Available in silver 		
Wire Management Sleeve 	WMS-42	1 lb.	\$46
	Description: <ul style="list-style-type: none"> · Expandable zip up nylon mesh management sleeve · 42" length · Available in black 		
Fokus Task Light 	FOKUS-2-___		\$485
	Description: <ul style="list-style-type: none"> · LED · 11 watts · 15,000 hours light lifespan · 3000k color temperature · 3-way touch dimmer (10%, 50%, 100%) · Base dimension: Ø 5.9" · Freestanding · ETL, FFC and CEC certified Notes: <ul style="list-style-type: none"> · Specify color: White (WH) Black (BK) 		
Docking Station 	DS-1-BLK DS-1-CM-BLK (w/Clamp Mount) DS-1-VM-BLK (w/VESA Mount)		\$835 \$994 \$949
	Description: <ul style="list-style-type: none"> · Mac and PC compatible · Dimensions: 3.75" W x 3.75" D x 1.33" H · Docking Interface: USB-C 3.1 · Interfaces: (2) HDMI 1.4, (3) USB-A 3.1 Gen 1, (1) RJ45 Port, (1) Audio Jack In/Out · Single Display Resolution: 2560 x 1440 @ 50Hz · Dual Display Resolution: 1920 x 1080 @ 60Hz · Audio: 2.1 Channel · Ethernet: Type 10/100/100 Base-T · PD Charging: 85W · Power Adapter: AC 100/240V 		

1. VERTICAL WIRE MANAGEMENT SYSTEM

Exclusive to S-Collection workstations, the Vertical's flexible design manages wires on a vertical plane through a BIFMA-required range. The main unit attaches to the leg with magnets, allowing for flexibility of mounting and reconfiguration.

* Not compatible with panel integration or HAT bases.

439900-__

Black, Silver, White
22" - 48" Adjustable Height
\$206

Chain available in Black only.

2. POCKET CABLE MANAGEMENT

Keep cords neat and organized with an easy to install mesh cable management sleeve that is compatible with any base and work surface. Includes 12 velcro straps that securely lock in your wires.

Standard
CMT-04 (Black)
CMT-06 (Grey)
38" W x 5" D
\$205

Mini
CMT-24-04 (Black)
CMT-24-06 (Grey)
24" W x 5" D
\$155

3. FLEX WIRE MANAGEMENT TRAY

This tray comes in three sizes. Its flexible design and thin steel construction allow for high flexibility in mounting and configuration. Seams along the surface indicate where bending should occur.

990103-__

Black, Silver, White
22.4" W
\$106

990102-__

Black, Silver, White
43.7" W
\$118

990101-__

Black, Silver, White
55.5" W
\$133



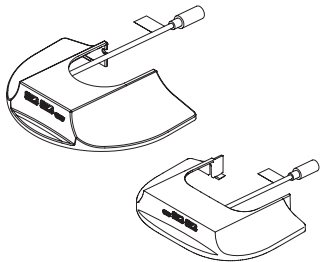
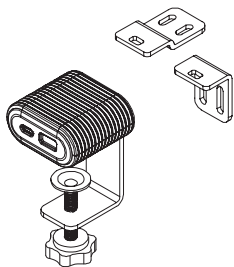
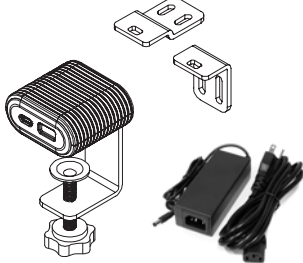
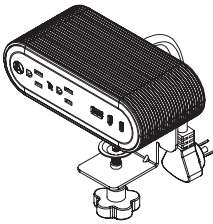
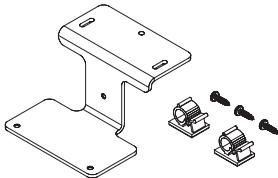

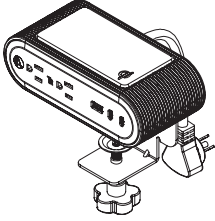
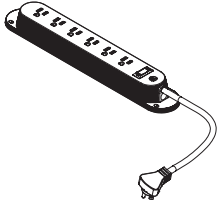
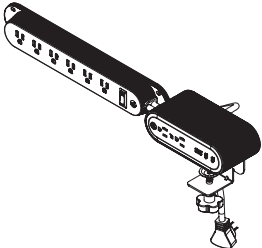
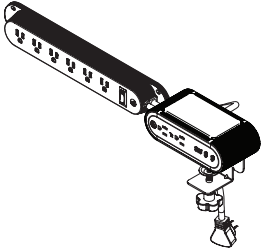
	MODEL	COMPATIBILITY	LIST PRICE
Snap on Charging Mount 	CHG-CAP-1-__ CHG-CAP-2-__ CHG-CAP-E-__	Single top down mount Dual top down mount Dual E2 top down mount	\$245 \$245 \$245
	Description: <ul style="list-style-type: none"> · Features 2 USB-A and 1 USB-C port · Input: 100-240VAC, 50/60Hz, 2.0A (Max.) · Output: 24VDC, 3A, 72W Notes: <ul style="list-style-type: none"> · Specify color: White (WH) Silver (SI) Black (BK) 		
Reya USB Hub 	PWR-AC-__		\$145
	Description: <ul style="list-style-type: none"> · Includes one USB-A port and a one USB-C port · Can charge laptop up to 65 Watts · Mount: Desk edge/surface mount, under mount, edge mount · Desk edge/surface mount: 0.5" - 1.75" · Compatible with Mid and Hi HAT only (requires PWR-AC-PS for use with other bases) Notes: <ul style="list-style-type: none"> · Specify color: Black (BK) White (WH) 		
Reya USB Hub with AC Power Adapter 	PWR-AC-PS-__		\$220
	Description: <ul style="list-style-type: none"> · Includes one USB-A port and a one USB-C port · Can charge laptop up to 65 Watts · Mount: Desk edge/surface mount, under mount, edge mount · Desk edge/surface mount: 0.5" - 1.75" · Includes AC Adapter and power cable. Notes: <ul style="list-style-type: none"> · Specify color: Black (BK) White (WH) 		
Reya Standard Surface Power Module 	PWR-ACC-__		\$325
	Description: <ul style="list-style-type: none"> · Features 2 power receptacles, 1 USB-A and 2 USB-C ports · Charges laptops up to 65W · Mount: Desk edge, 0.75" - 1.75" Notes: <ul style="list-style-type: none"> · Specify color: White (WH) Black (BK) 		
Under Mount Kit for Reya Standard Surface Power Module 	PWR-UM-CK		\$49
	Description: <ul style="list-style-type: none"> · Conversion kit allows the Reya Standard Surface Power Module to be mounted underneath worksurface · Includes mounting bracket, screws, and wire management clips (Reya Standard Surface Power Module sold separately) · Black finish 		



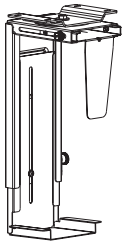
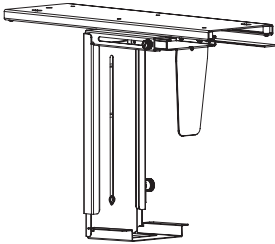
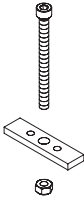
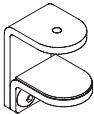
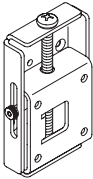
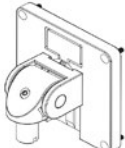

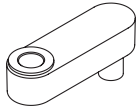
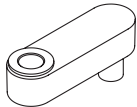
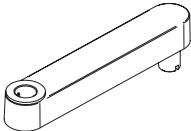
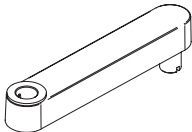
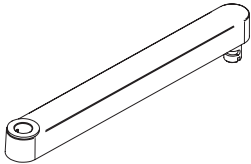
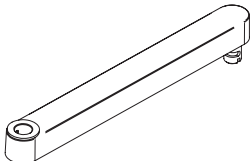
	MODEL	LIST PRICE
<p>Reya Wireless Surface Power Module</p> 	<p>PWR-ACC-WRLS-__</p> <p>Description:</p> <ul style="list-style-type: none"> · Features 2 power receptacles, 1 USB-A and 2 USB-C ports · Charges laptops up to 65W · Fast wireless charging · Mount: Desk edge, 0.75" - 1.75" <p>Notes:</p> <ul style="list-style-type: none"> · Specify color: White (WH) Black (BK) 	<p>\$475</p>
<p>Reya Power Strip</p> 	<p>PWR-STRP-__</p> <p>Description:</p> <ul style="list-style-type: none"> · 6 power receptacles · Input: 125VAC, 60Hz, 15A max · Output: AC Outlets (6): 120VAC, 60HZ, 15A max <p>Notes:</p> <ul style="list-style-type: none"> · Specify color: White (WH) Black (BK) 	<p>\$130</p>
<p>Reya Power Strip with Hardwired Standard Surface Power Module</p> 	<p>PWR-ACC-STRP-__</p> <p>Description:</p> <ul style="list-style-type: none"> · Charges laptops up to 65W · Mount: Desk edge, 0.75" - 1.75" <p>Surface module:</p> <ul style="list-style-type: none"> · Features 2 power receptacles, 1 USB-A and 2 USB-C ports <p>Power Strip</p> <ul style="list-style-type: none"> · 6 power receptacles · Input: 125VAC, 60Hz, 15A max · Output: AC Outlets (6): 120VAC, 60HZ, 15A max <p>Notes:</p> <ul style="list-style-type: none"> · Specify color: White (WH) Black (BK) 	<p>\$500</p>
<p>Reya Power Strip with Hardwired Wireless Surface Power Module</p> 	<p>PWR-ACC-WRLS-STRP-__</p> <p>Description:</p> <ul style="list-style-type: none"> · Charges laptops up to 65W · Mount: Desk edge, 0.75" - 1.75" <p>Wireless Surface Module:</p> <ul style="list-style-type: none"> · Features 2 power receptacles, 1 USB-A and 2 USB-C ports, fast wireless charging <p>Power Strip</p> <ul style="list-style-type: none"> · 6 power receptacles · Input: 125VAC, 60Hz, 15A max · Output: AC Outlets (6): 120VAC, 60HZ, 15A max <p>Notes:</p> <ul style="list-style-type: none"> · Specify color: White (WH) Black (BK) 	<p>\$650</p>

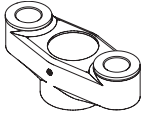

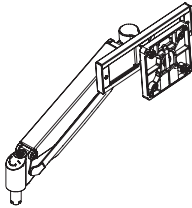
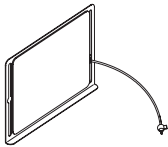
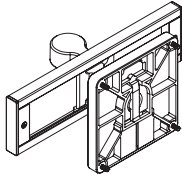
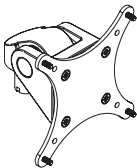
	MODEL	WEIGHT	LIST PRICE
CPU Holder 	CPU-HLDR-1	7 lbs.	\$168
	Description: <ul style="list-style-type: none"> · 22 lbs. max weight capacity · Supports computers 11.8" - 21" H, 3.5" - 8" D · 360 degree swivel · Mount under desk or on wall · Available in black 		
CPU Holder w/Track 	CPU-HLDR-2	12 lbs.	\$203
	Description: <ul style="list-style-type: none"> · 22 lbs max weight capacity · Supports computers 11.8" - 21" H, 3.5" - 8" D · Slide track: 5.79" x 19.09" · Track adjustment: 12.8" · 360 degree swivel · Minimum worksurface depth: 20" · Mount under desk · Available in black · Not compatible with Mid HAT & Hi HAT bases 		
Thru-Desk Conversion Kit for Top Down Mounts 	8524-TM-CK (compatible with single top down mount) 8540-TM-CK (compatible with E2 dual)		No Charge
	Description: <ul style="list-style-type: none"> · Hardware kit to convert top down mount desk edge mount to thru-desk · Desk thickness up to 1.5" · Bolt is M8 x 100mm Notes: <ul style="list-style-type: none"> · Hardware only, does not include mount 		
FlexMount Conversion Kit for Top Down Mounts 	8524-FM-CK		\$67
	Description: <ul style="list-style-type: none"> · Hardware kit to convert top down mount to flex mount · 2-piece clamp for panel/screen systems · Desk thickness up to 1.5" Notes: <ul style="list-style-type: none"> · Hardware only, does not include mount 		
Height Adjustable Adapter 	8473-603		\$42
	Description: <ul style="list-style-type: none"> · Allows for fine-tune monitor height adjustment · Attaches between tilter and VESA plate · Compatible with 7000 and Staxx series monitor mounts Notes: <ul style="list-style-type: none"> · Color: Black e-coat 		
Next Gen Tilter 	8500-___		\$61
	Description: <ul style="list-style-type: none"> · Quick-install/quick-release mechanism Notes: <ul style="list-style-type: none"> · Specify color: Black (104) Silver (124) White (248) 		

	MODEL	LIST PRICE
4 in. extension arm 	9118-9112-___	\$62
	Description: · 4 in. extension arm Notes: · Specify color: Black (104) Silver (124) White (248)	
4 in. extension arm with rotation stop 	9118-9112-RS-___	\$174
	Description: · 4 in. extension arm with rotation stop · For use with E2 Connex Notes: · Specify color: Black (104) Silver (124) White (248)	
8.5 in. extension arm 	9118-9130-___	\$95
	Description: · 8.5 in. extension arm Notes: · Specify color: Black (104) Silver (124) White (248)	
8.5 in. extension arm with rotation stop 	9118-9130-RS-___	\$185
	Description: · 8.5 in. extension arm with rotation stop · For use with E2 Connex Notes: · Specify color: Black (104) Silver (124) White (248)	
12 in. extension arm 	9118-12	\$121
	Description: · 12 in. extension arm-___ Notes: · Specify color: Black (104) Silver (124) White (248)	
12 in. extension arm with rotation stop 	9118-12-RS-___	\$209
	Description: · 12 in. extension arm with rotation stop · For use with E2 Connex Notes: · Specify color: Black (104) Silver (124) White (248)	

	MODEL	LIST PRICE
E2 Connex Dual Yoke 	8360-RS-___	\$219
	Description: · Dual yoke allows you to expand your E2 Connex configuration Notes: · Specify color: Black (104) Silver (124) White (248)	
E2 Connex 28" Pole 	8448-14-___ (14" pole length) 8448-28-___ (28" pole length)	\$65 \$86
	Description: · 14" or 28" pole length, compatible with E2 Connex components Notes: · Specify color: Black (104) Silver (124) White (248)	
E2 Connex Dynamic Arm 	E2-ARM-SLD-___	\$248
	Description: · E2 Connex Dynamic Arm with slider and VESA adapter Notes: · Specify color: Black (104) Silver (124) White (248)	
8510 Laptop Tray 	8510-___	\$137
	Description: · 13.5" x 10" · Allows for use of laptop with dual triple monitor configuration · Compatible with 100 mm VESA hole pattern Notes: · Specify color: Black (104) Silver (124) White (248)	
Sliding VESA Assembly 	8538-___	\$65
	Description: · 7" of adjustment from left to right · Ideal for positioning monitors of varying sizes side-by-side · Allows for landscape/portrait monitor positioning Notes: · Specify color: Black (104) Silver (124) White (248)	
HD Tilter 	8377-175-___	\$147
	Description: · Allows for landscape/portrait monitor positioning · Monitor tilter mechanism can tilt over 200 degrees Notes: · Specify color: Black (104) Silver (124) White (248)	

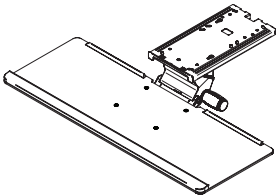
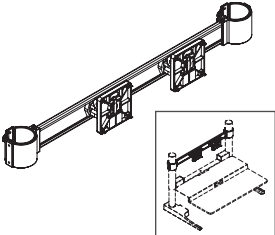
	MODEL	WEIGHT	LIST PRICE
Winston Mat 	WNST-MAT		\$82
	Description: <ul style="list-style-type: none"> · .75" thick durable foam delivers deep-cushion comfort. · Bounce-back memory restores energy while standing. · Durable, stain-resistant surface. · Material: Commercial grade, heavy-duty polyurethane. 		
Casters 	CAS-37 4 CAS-37 5	2 lbs. 3 lbs.	\$78 \$98
	CAS-37 4 Description: <ul style="list-style-type: none"> · Set of four 37mm dual wheel casters (2 locking, 2 non locking) · For 2 leg HAT base (compatible with HAT bases only) · Available in black 		
	CAS-37 5 Description: <ul style="list-style-type: none"> · Set of five 37mm dual wheel casters (2 locking, 3 non locking) · For 3 leg base (compatible with HAT bases only) · Available in black 		
FlexShield 	SHIELD-2430-WHT	12 lbs.	\$357
	Description: <ul style="list-style-type: none"> · 24" W x 30" H, Pass through window: 12" W x 3.5" H · Constructed of polycarbonate: 250 times stronger than glass and virtually indestructible 		
FlexShield Wings 	SHIELD-WINGS	9 lbs.	\$269
	Description: <ul style="list-style-type: none"> · 11.75" W x 30" H · Flexible extruded hinges with adhesive allows user you to configure panels at any angle (requires FlexShield) · Constructed of polycarbonate: 250 times stronger than glass and virtually indestructible · Sold in pairs 		
Keyboard Tray 	KT-27	12 lbs.	\$350
	Description: <ul style="list-style-type: none"> · Tilt adjustment, +10/-10 degrees · 11" track · 360 degree swivel · Keyboard tray size 27" W x 10" D with polyurethane foam wrist rest · Built-in mouse tray on left and right side (mouse pad can be repositioned) · Exceeds ANSI/BIFMA x5.5 · Available in black 		
Winston E-Desk Beam 	WNSTE-DESK-BEAM-__ _		\$191
	Description: <ul style="list-style-type: none"> · Screen size: up to 27" · Weight capacity: up to 45 lbs. total · Compatible with Winston E-Desk 		
	Notes: <ul style="list-style-type: none"> · Specify color: Black (BLK) White (WHT) 		

ACCESSORIES

GROMMETS

60MM Grommet
#CPF-2600
 \$11

BAG HOOK

BAG HOOK
#BH-S-XX
 Silver, Black, White
 \$44

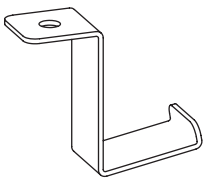

CASTERS + GLIDES

(1) 1" ERGO CASTER
#8027
 Locking
 \$34

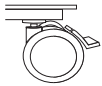

(1) 2" ERGO CASTER
#8033
 Locking
 \$40

(1) 2" ERGO CASTER
 (ELLE & ELLEHAVEN)
#8036
 Locking
 \$62

(1) 3" SOFT WHEEL CASTER
#8028
 Locking
 \$89

(1) GLIDE EXTENDER
#R015139
 \$23

POWER + DATA

(ELLEHAVEN) INLAY
POWER, DATA, & USB

#D3P4USBSUR-XX-72
 Black, White
 \$900

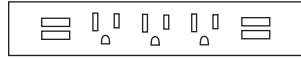

#D3PSUR-XX-72
 Black, White
 \$477



BATTERY PACK

BATTERY PACK

#BP-KIT
 \$755
 Includes 1 Battery.

BATTERY KIT

#BP-KIT2
 \$1,928
 Includes 2 Batteries,
 1 charging station, and
 2 control boxes. Configured
 to convert an Ellehaven or Elle
 from corded to battery operated.

UNDER SURFACE POWER

UNDER SURFACE

6X POWER
#NLD6PCOIL-B-120
 \$258

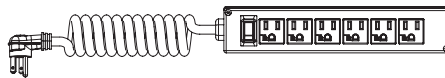

CABLE TRAYS (ELLE & ELLEHAVEN)

ELLE CABLE TRAY

Adjustable, 39.6" - 63.6", Black
#17000010
 \$348

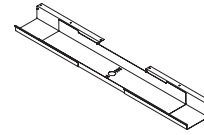

ELLEHAVEN CABLE TRAYS

84", Black
#400000008410
 \$467

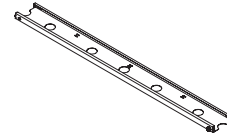

96", Black
#400000009610
 \$493

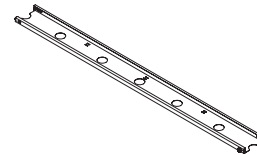

96", Frames 108"-120" x 36" Gable, Black
#400010812010
 \$864

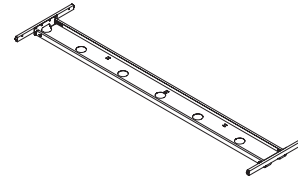

96", Frames 108"-120" x 42" Gable, Black
#400110812010
 \$898

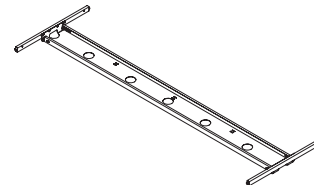

96", Frames 108"-120" x 48" Gable, Black
#400210812010
 \$920

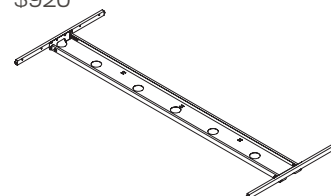



MATERIALS

METAL

Bases

In-Stock:

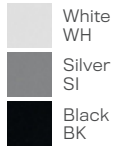

Standard:

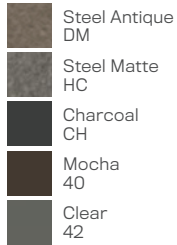

Power & Data Beam

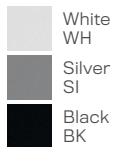

Storage

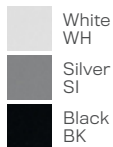

Desktop Converters

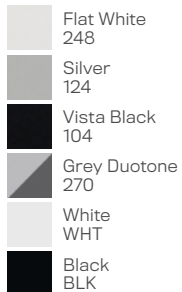

Monitor Arms

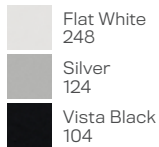

LAMINATES & WOOD

Laminates

In-Stock & Standard:

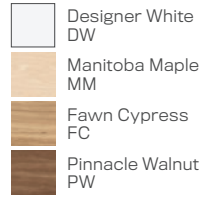

Laminates (Fiellø)

Standard:

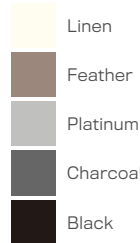

Wood (Fiellø)

Standard:

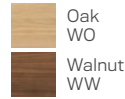

PET & FABRIC

PET

In-Stock:



Standard:



Recycled PET (Aura & Fiellø)

Standard:

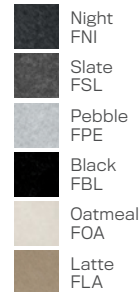

Fabric

Elements Line (Grade 1)

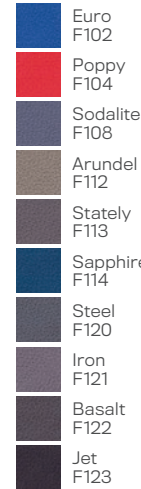



Fabric

Fusion Line (Grade 2)

































ACRYLIC & WHITE BOARD

Standard:

-  Clear Acrylic
CLA
-  Frosted Acrylic
FRA
-  White Board
WB

STORAGE CUSHIONS



In-Stock:

-  Charcoal
15-13
-  Sapphire
15-03
-  Poppy
15-04
-  Mica
15-07
-  Salmon
15-08
-  Garnet
15-11
-  Meadow
15-15
-  Mauve
15-16
-  Taupe
15-17
-  Fern
15-18
-  Teal
15-19
-  Black
15-21
-  Sodalite
15-41
-  Blue
15-44
-  Iron
15-48
-  Seafoam
15-49
-  Orange
15-75
-  Rust
15-102
-  Yellow
15-104
-  Khaki
15-106
-  Brown
15-109
-  Lilac
15-110
-  Frost Green
15-118
-  Denim
15-153
-  Mustard
15-155
-  Blue Green
15-161
-  Fez
15-164
-  Midnight
15-167
-  Sapphire
15-173
-  Purple
15-184

Standard:

SEATING

Frame:

-  White
W
-  Black
B

Mesh:

-  Cloud
M3H
-  Smoke
M2H
-  Raven
M1H

Seat Upholstery:

-  Alloy
ALLOY
-  Iron
IRON
-  Jet
JET

Base:

-  Polished Aluminum
S1PB
-  Black Nylon
S1BB

IN-STOCK

Bases

-  White
WH
-  Silver
SI
-  Black
BK





Power & Data Beam

-  White
WH
-  Silver
SI
-  Black
BK



Storage (HAT Pedestals)

-  White
WH
-  Silver
SI
-  Black
BK





Desktop Converters

-  Silver
124
-  Vista Black
104
-  Grey Duotone
270
-  White
WHT
-  Black
BLK

Monitor Arms

-  Silver
124
-  Vista Black
104

Laminates

-  Designer White
DW
-  Manitoba Maple
MM
-  Fawn Cypress
FC
-  Pinnacle Walnut
PW

Dividers (PET)

-  Ash
ASH
-  Slate
SLATE
-  Charcoal*
CHARCOAL
-  Iced Grey*
IG

Pedestal Cushion

-  Charcoal
15-13

Seating

Frame:

-  Black
B

Mesh:

-  Raven
M1H

Seat Upholstery:

-  Jet
JET

Base:

-  Black Nylon
S1BB



HAT
COLLECTIVE™
HUMAN ACTIVE TECHNOLOGY

HAT Collective
Global Headquarters
100 Kuebler Road
Easton, PA 18040

800 524 2744
hatcollective.com

