



List Pricebook
Updated March 4, 2024



HAT
DESIGN WORKS™
HUMAN ACTIVE TECHNOLOGY

Table of Contents

Introduction

Warranty4
 Terms + Conditions5-7
 Lead Times.....8-10
 Freight Estimate Tool..... 11

Desktop Converters

Winston Desk®

Winston E-Desk 12

Winston-E®

Winston-E® Single Compact..... 13
 Winston-E® Dual Compact 13
 Winston-E® Triple Compact..... 13
 Winston-E® Single..... 14
 Winston-E® Dual 14
 Winston-E® Triple..... 14

Winston Workstation®

Winston Workstation® Single Compact 15
 Winston Workstation® Dual Compact..... 15
 Winston Workstation® Triple Compact 15
 Winston Workstation® Quad Compact 15
 Winston Workstation® Single 16
 Winston Workstation® Dual..... 16
 Winston Workstation® Triple 16
 Winston Workstation® Quad 16

One Touch

One Touch Single17
 One Touch Dual17
 One Touch Triple17
 One Touch 1 over 1..... 18
 One Touch 2 over 2..... 18
 One Touch 3 over 3..... 18

Monitor Arms

Envoy™ 19
 Dual Envoy™ 19
 E2 19
 Dual E220

E2 Connex

E2 Connex Single20
 E2 Connex Dynamic Dual20
 E2 Connex Dynamic Dual Wide20
 E2 Connex Dynamic Triple..... 21
 E2 Connex Static Dual 21
 E2 Connex Static Triple 21
 E2 Connex One over One..... 21

700022
 7000-840822
 7000 Dual Crossbar22
 7000-Switch.....23
 750023
 7500-Wing23
 7000-T.....24
 705024
 7050-SWITCH24

Staxx Modular System

Staxx™ Single25
 Staxx™ Dual25
 Staxx™ Triple25
 Staxx™ 1 over 1.....25
 Staxx™ 2 over 2.....26
 Staxx™ 3 over 3.....26
 Staxx™ Dual Articulating26
 Staxx™ Articulating Monitor and Laptop 27
 Staxx™ Stackable Pole Mount Cup..... 27

Bild® Multi-Monitor System

Bild® Dual28
 Bild® Triple.....28
 Bild® Quad.....28
 Bild® 2 over 229
 Bild® 3 over 329
 Bild® 4 over 429

9136 Series

9136-S-14..... 30
 9136-S-14-FM 30
 9136-D-28..... 30
 9136-D-28-FM 30

9112 Series

9112-S-14..... 31
 9112-S-14-FM 31
 9112-D-28..... 31
 9112-D-28-FM 31

9130 Series

9130-S-14.....32
 9130-S-14-FM32
 9130-D-28.....32
 9130-D-28-FM32

Table of Contents (continued)

9120 Series

9120-S-14	33
9120-S-14-FM	33
9120-D-28	33
9120-D-28-FM	33

9163 Series

9163-S-14	34
9163-S-14-FM	34
9163-D-28	34
9163-D-28-FM	34

Vertical Wall Track System

8326	35
8328	35
7509-NM	35
7019-500HY-NM	36
8335 CPU Mounts	36

9110 Series

9110	37
9110-4	37
9110-4-4	37
9110-8.5	38
9110-8.5-4	38
9110-8.5-8.5	38

Accessories

VESA

8538	39
------------	----

Mounts

8111	39
8408	39
8246	40

Extender Tubes

8171-6 / 8171-75-6	40
--------------------------	----

Extension Arms

9118-9112 / 9118-9130	40
-----------------------------	----

Dual Monitor Bracket

8428 (Switch™)	41
Winston E-Desk Beam	41

Power

Snap On Charging Caps	42
Reya	42-43

Keyboard Arms + Trays

KT-27	44
-------------	----

Cable Management

Pocket	44
--------------	----

Storage

Mobile Pedestals	44
------------------------	----

Warranty

Seller warrants that its products will be free from defects in material and workmanship when the title passes to the buyer. Seller will repair or replace, at its discretion, any defective product without charge (shipping charges excluded) for a period of 10 years (exception: 1 year for Busby®, 5 years for Winston Workstation®, Winston Lift®, Winston-E®, Winston Desk®, Winston Mat and 3 years for Tablik® and 1 year for Bild® motorized column) after the original date of sale, unless the product damage resulted from normal wear and tear, buyer abuse, misuse or negligence or failure to follow instructions related to the product's installation or intended use. Seller may require proof of purchase before performing any repairs or replacing any products during the warranty period. Except as specifically set forth above, seller makes no warranties, express or implied and specifically disclaims any warranty of merchantability or fitness for a particular purpose. Repair or replacement of the product ordered from seller shall be buyer's exclusive remedy.

Terms + Conditions

The following terms and conditions shall apply to all orders by buyer ("Buyer" or "you") for goods and services purchased from Human Active Technology (individually the "Seller" or "Us", and, together with Buyer, the "parties"). By accepting delivery, Buyer agrees to be bound by and accepts these terms and conditions. These terms and conditions supersede the terms and conditions of or attached to the Buyer's purchase order or any similar document submitted by Buyer (a "Purchase Order"), meaning any provision of the Buyer's Purchase Order or attachment thereto which conflicts with these terms and conditions shall be ineffective and these terms and conditions shall govern each Purchase Order unless the Seller shall subsequently agree otherwise in writing.

1. RESERVATION OF RIGHTS

Seller reserves the right to change at any time without notice these terms and conditions.

2. PAYMENT TERMS

a. CREDIT – Credit may be extended to Buyer at Seller's sole discretion. Credit approval is required for all orders on open account. All products, parts and services sold to Buyer on open account are due 'Net 30 Days' from date of invoice, unless otherwise agreed to in writing at the time of sale. A service charge at the then-current prevailing rate is assessed on delinquent balances. Seller reserves the right to change this rate or the 'Net 30 Days' payment due date from time to time. Service charges will be assessed monthly. The current rate is 1.5% per month (18% annually) or the maximum rate allowed by law, whichever is less. Buyer is responsible for cancellation costs and attorney's fees associated with collection of monies owed to Seller by Buyer. Buyer shall notify Seller in writing of errors contained in invoices within 30 days of issuance. Invoices are deemed correct 30 days following issuance. Credit accounts past due will be placed on hold— pending orders will not be shipped and work-in-process for pending orders will be stopped until account is made current by Buyer.

b. DEPOSIT FOR LARGE ORDERS – For orders from new customers of \$20,000 or more, standard terms are: 1/2 deposit with the Purchase Order and 1/2 payment prior to shipment. For orders from established customers of \$50,000 or more, standard terms are: 1/2 deposit with the Purchase Order and 1/2 payment Net 30 Days.

3. CURRENCY

All prices quoted and monies due are in U.S. dollars. For non-U.S. customers, payment may be made by certified check, wire transfer or VISA, MasterCard or American Express.

4. DELIVERY & FREIGHT

a. U.S. SHIPMENTS – Unless otherwise negotiated, standard freight terms for order shipments within the 48 contiguous states of the United States are prepay and add to final invoice. Seller reserves the right to reasonably charge the buyer for all non-standard delivery requirements which may include but are not limited to:

- Consolidation and delivery on the same truck
- Expedited or air freight
- Special shipping or packaging methods
- Liftgates/forklift
- Delivery outside of normal hours
- Inside delivery
- Redelivery, notification, etc.
- Improper refusal of product
- Detention charges
- Street unloads
- Redirection of product
- Storage past acknowledged ship date

(All products in the catalog will receive ship dates respective of their product category and can be found on the following page: 9.

i. Title passes to Buyer at the dock of the shipping origin. Choice of carrier is at Seller's discretion, unless specified by Buyer's Purchase Order. Freight charges are added to Buyer's invoice unless Buyer's Purchase Order specifies carrier routing, notes "freight collect," and includes applicable carrier account numbers and/or billing information.

ii. For Alaska – freight is prepaid to Port of Seattle, Washington. For Hawaii, freight is prepaid to Port of Oakland, California.

iii. Customer arranged pick up (will-call) is available with timely and reasonable coordination. Once confirmed, Buyer will have three (3) business days from notification to pick up the order. If the order is not picked up within this time frame, storage charges may apply.

iv. All requests for carrier-guaranteed delivery times shall be considered and will include an additional fee, if accepted. This additional fee will be the maximum liability to the Seller. If the carrier misses the guaranteed delivery time, a refund will be issued to customer.

b. NON-U.S. SHIPMENTS – Unless otherwise negotiated and accepted by the Seller in writing, shipments outside of the U.S. are shipped Freight On Board (FOB) Origin or Shipping Origin. Title passes to Buyer at the dock of Shipping Origin regardless of method of shipment. Transportation costs will be added to invoice unless Buyer's Purchase Order specifies carrier routing, notes "freight collect" and includes applicable carrier account numbers and/or billing information. Unless otherwise negotiated, Buyer is responsible for arranging customs clearance and for filing and paying all applicable duties and taxes outside of the United States.

c. DAMAGE – Seller is not responsible for damage that occurred in transit or during storage. Before accepting a shipment from the carrier, Buyer (and/or its designated receiver) is to carefully review the packing list and inspect the quantity and condition of the items. For any external damage, Buyer should document all damage on the Bill of Lading and request a carrier inspection of the product.

d. CONCEALED DAMAGE – Buyer must report concealed damage to the carrier and Seller, in writing, within 48 hours of receipt. In the event of damage, Buyer shall accept the order and contact Seller for issue resolution. Seller agrees to take all reasonable measures to assist Buyer in resolving claims for loss or damage.

e. EARLY SHIPMENTS – Estimated ship dates are sent with order acknowledgements. Seller may ship up to 5 days early, unless requested otherwise on Buyer's Purchase Order.

f. REPACKING CHARGES – Any Buyer requests to change shipment methods or destinations stated on Purchase Order, or any requests from Buyer for special packaging not stated on Purchase Order may result in repacking charges if requests require Seller to repack order.

5. TAXES AND DUTIES

Buyer shall be responsible for all taxes and duties which result from the transfer of title, sale or delivery of the goods and services purchased hereunder. Taxes may not be applied if a valid and correct tax exemption certificate is furnished to Seller prior to shipment.

6. CANCELLATIONS

Purchase Orders may not be changed or canceled, in whole or in part, without prior written consent of Seller. Changes or revisions must be clearly indicated on the new Purchase Order and may affect delivery dates. Expenses incurred because of changes will be charged to the Buyer as customer. In the event of cancellations, the customer will be liable for reasonable cancellation charges established by Seller. Charges may be incurred by Buyer for the entire amount of the order. Orders for customized products, custom finishes or applying Customer's Own Material (COM) may not be canceled. All such custom orders are final and non-refundable.

Terms + Conditions (continued)

7. RETURNS AND CLAIM POLICY

a. **RESPONSIBILITY.** It is Buyer's responsibility to examine goods upon receipt and to notify Seller with any concerns. Any claims against Seller for apparent defects, errors or shortages must be made by the Buyer within 48 hours after any receipt date. Failure by the Buyer to make any claim against Seller within 48 hours shall constitute acceptance of the goods and waive any apparent defects, errors or shortages.

b. **DEFECTIVE ITEMS** – Defective items may be returned within limits of the Warranty.

c. **CUSTOM-CONFIGURED ITEMS** – Non-defective Custom-configured Items are not returnable.

d. RETURNS

Authorized merchandise returns must be approved prior to the arrival of any goods at our dock. Unauthorized returns will not be accepted by Seller. All returns must be labeled with a valid Return Authorization (R/A) number on the outside of packaging. Shipments without R/A numbers will be rejected. R/A numbers may be obtained by calling Seller. Products must be returned to Seller within 30 days of receipt. Returns are subject to up to a 25% restocking fee plus return freight charges. Product must be returned in original cartons in "as new" condition.

8. BLANKET ORDERS

Blanket Orders include any order by Buyer to be received in multiple shipments ("releases").

· Buyer must accept all releases within 6 months of Purchase Order receipt, unless agreed by Seller otherwise in writing. Units not requested to be shipped by Buyer within 6 months of Purchase Order receipt will be shipped and invoiced to Buyer immediately following the 6 month deadline. Cancellation and order change fees apply as specified in sections 6a and 6b.

9. WARRANTY

Seller warrants that its products will be free from defects in material and workmanship when the title passes to the Buyer. Seller will repair (only pre-approved labor and service costs are covered under this warranty) or replace (or issue a pro-rated credit if a similar product is no longer available) at its discretion any defective product without charge (shipping charges excluded).

Seller may require proof of purchase before performing any repairs or replacing any products during the warranty period. Except as specifically set forth above, Seller makes no warranties, express or implied, and specifically disclaims any warranty of merchantability or fitness for a particular purpose. Repair or replacement of the product ordered from Seller shall be Buyer's exclusive remedy. Seller will not be responsible for incidental or consequential damages.

THIS WARRANTY DOES NOT APPLY TO:

- Damage caused by a carrier.
- Buyer's labor charges.
- Normal use, wear and tear.*
- Defects caused by failure to follow instructions related to the product's installation or intended use.
- Products subjected to improper use and conditions.
- User modification of, or attachments to the product, including application of your own materials (i.e., COM) or a third party's materials
- Damage resulting from misuse, negligence, accident or alteration.

*Normal use consists of a 5 day, 40 hour work week.

This warranty shall be effective for the applicable time period starting from date of purchase as shown on your original receipt or other proof of purchase. The warranty covers the original purchaser of the product.

Individual product warranty time periods can be found on the Seller's websites.

10. INSTALLATION

Seller does not take responsibility for Buyer's installation of Seller's products. Buyer must supply own installation or acquire installation services from a third party.

11. ONLINE AUCTIONS

Buyer agrees that product purchased from Seller will not be sold at online auction for less than Seller's suggested retail price, unless clearly marked as "Used" in both auction subject line and descriptive text. Buyer is obligated to inform prospective bidders that Seller's warranties are voided by sale at online auction and product purchased at online auction may not for any reason be returned to Seller for repair, credit or exchange. Seller reserves the right to refuse to sell to any Buyer discovered to be in violation of these terms and conditions.

12. RESALE

Subject to Section 11, on any resale of purchased items the Buyer will contractually limit its buyer's rights and remedies against both Buyer and Seller to the same extent as Buyer's rights and remedies covered in Warranty and Returns and Claim Policy above.

13. PERMITS & COMPLIANCE

Seller is not responsible for obtaining any permits, inspections or licenses required for installation or operation of the goods or services. Seller makes no promise or representation that the goods or services will conform to any federal, state, local, foreign or other laws, ordinances, regulations, codes or standards.

14. LIMITED LIABILITY

The entire liability of Seller to Buyer for any cause whatsoever, regardless of the form of action, whether in contract, tort or otherwise, shall be limited to the direct damages proven or an amount equal to the purchase price of the products or services, whichever is less. In no event shall Seller be liable for any indirect, special reliance, incidental or consequential damages (including lost profits or savings) sustained or incurred in connection with the product. This paragraph shall survive failure of any exclusive remedy.

15. NON-WAIVER

Any failure on Seller's part to insist upon the strict performance of any term or condition set forth herein shall not be deemed a waiver of any of Seller's rights or remedies hereunder, nor of its right to insist upon the strict performance of the same or of any other term of this document in the future. No waiver of any condition of this document shall be valid unless in writing and signed by an authorized representative of Seller.

16. PREVAILING LAW

The parties hereto hereby agree that these terms and conditions (and all Purchase Orders) shall be governed by and construed in accordance with, for all purposes, the laws of the Commonwealth of Pennsylvania, without reference to its rules concerning conflicts of laws, and further agree that the Pennsylvania State courts or the federal court for the Eastern District of Pennsylvania shall have exclusive jurisdiction to hear and determine any suit instituted under these terms and conditions (and all Purchase Orders). Each party expressly submits in advance to such jurisdiction in any action or proceeding commenced by the other, and agrees that service of such summons and complaint, or other process or papers, may be made in accordance with the physical Notice provisions hereof concerning certified mail, return receipt requested.

Terms + Conditions (continued)

17. NOTICE

The parties may give notice to each other by certified mail, return receipt requested or overnight courier, according to the addresses set forth in the Purchase Order. Ordinary course email notice may be given concerning details of or changes to any given Purchase Order, provided the sender has received electronic confirmation of

Lead Times*

DESKTOP CONVERTERS				
MODEL	1-10 UNITS	11-25 UNITS	26-50 UNITS	51+ UNITS
WNSTE-DESK	3 Days	5 Days	7 Days	Call
WNSTE-1-CW	5 Days	7 Days	10 Days	Call
WNSTE-2-CW	5 Days	7 Days	10 Days	Call
WNSTE-3-CW	5 Days	7 Days	10 Days	Call
WNSTE-1	3 Days	5 Days	7 Days	Call
WNSTE-2	3 Days	5 Days	7 Days	Call
WNSTE-3	3 Days	5 Days	7 Days	Call
WNST-1-CW	1 Day	3 Days	5 Days	Call
WNST-2-CW	3 Days	5 Days	7 Days	Call
WNST-3-CW	3 Days	5 Days	7 Days	Call
WNST-4-CW	20 Days	20 Days	20 Days	Call
WNST-1	1 Day	3 Days	5 Days	Call
WNST-2	1 Day	3 Days	5 Days	Call
WNST-3	3 Days	5 Days	7 Days	Call
WNST-4	3 Days	5 Days	7 Days	Call
1TCH-1	20 Days	20 Days	20 Days	Call
1TCH-2	20 Days	20 Days	20 Days	Call
1TCH-3	20 Days	20 Days	20 Days	Call
1TCH-1/1	20 Days	20 Days	20 Days	Call
1TCH-2/2	20 Days	20 Days	20 Days	Call
1TCH-3/3	20 Days	20 Days	20 Days	Call

WINSTON WORKSTATION* ACCESSORIES				
MODEL	1-10 UNITS	11-25 UNITS	26-50 UNITS	51+ UNITS
8501 (Laptop Holder)	20 Days	20 Days	20 Days	Call

* Finish 248 (White) has a 20 day lead time.

Lead Times* (continued)

ARTICULATING MOUNTS				
MODEL	1-10 UNITS	11-25 UNITS	26-50 UNITS	51+ Units
ENVOY-1	3 Days	5 Days	7 Days	Call
ENVOY-2	3 Days	5 Days	7 Days	Call
E2-1	Next Day	3 Days	5 Days	Call
E2-2	Next Day	3 Days	5 Days	Call

MODEL	1-49 UNITS	50-149 UNITS	150+ UNITS
E2 Connex (all)	20 Days	Call	Call
7000	2 Days	2 Days	Call
7000-2	2 Days	4 Days	Call
7000-1-8537H	2 Days	4 Days	Call
7000-Switch	2 Days	4 Days	Call
7500	2 Days	4 Days	Call
7500-Wing	2 Days	4 Days	Call

LAPTOP + TABLET MOUNTS			
MODEL	1-49 UNITS	50-149 UNITS	150+ UNITS
7000-T	2 Days	4 Days	Call
7050	2 Days	4 Days	Call
7050-SWITCH	2 Days	4 Days	Call

STAXX™ MODULAR SYSTEM				
MODEL	1-10 UNITS	11-25 UNITS	26-50 UNITS	51+ Units
STX (all)	3 Days	5 Days	7 Days	Call

BILD® MULTI-MONITOR SYSTEM				
MODEL	1-10 UNITS	11-25 UNITS	26-50 UNITS	51+ UNITS
BILD-2 (-CM, -TM, -RM)	3 Days	5 Days	7 Days	Call
BILD-3 (-CM, -TM, -RM)	3 Days	5 Days	7 Days	Call
BILD-4 (-CM, -TM, -RM)	3 Days	5 Days	7 Days	Call
BILD-2/2 (-CM, -TM, -RM)	3 Days	5 Days	7 Days	Call
BILD-3/3 (-CM, -TM, -RM)	3 Days	5 Days	7 Days	Call
BILD-4/4 (-CM, -TM, -RM)	3 Days	5 Days	7 Days	Call

* Finish 248 (White) has a 20 day lead time.

Lead Times* (continued)

POLE MOUNTS				
MODEL	1-10 UNITS	11-25 UNITS	25-50 UNITS	51+ UNITS
9136-S-14-FM	3 Days	5 Days	7 Days	Call
9136-D-28-FM	3 Days	5 Days	7 Days	Call
9112-S-14-FM	3 Days	5 Days	7 Days	Call
9112-D-28-FM	3 Days	5 Days	7 Days	Call
9130-S-14-FM	3 Days	5 Days	7 Days	Call
9130-D-28-FM	3 Days	5 Days	7 Days	Call
9120-S-14-FM	3 Days	5 Days	7 Days	Call

WALL MOUNTS				
MODEL	1-10 UNITS	11-25 UNITS	25-50 UNITS	51+ UNITS
8326 WALL TRACKS	20 Days	20 Days	20 Days	Call
8328	20 Days	20 Days	20 Days	Call
7509-NM	20 Days	20 Days	20 Days	Call
7019-500HY-NM	20 Days	20 Days	20 Days	Call
8335 CPU MOUNTS	20 Days	20 Days	20 Days	Call

MODEL	1-49 UNITS	50-149 UNITS	150+ UNITS
9110	Next Day	2 Days	Call
9110-4	2 Days	4 Days	Call
9110-4-4	2 Days	4 Days	Call
9110-8.5	2 Days	4 Days	Call
9110-8.5-4	Next Day	2 Days	Call
9110-8.5-8.5	2 Days	4 Days	Call

MOUNTS + ACCESSORIES			
MODEL	1-49 UNITS	50-149 UNITS	150+ UNITS
8538	Call	Call	Call
8111	2 Days	4 Days	Call
8246	2 Days	4 Days	Call
8428	20 Days	20 Days	20 Days
KT-27	20 Days	20 Days	20 Days
Mobile Pedestals	3 Days	3 Days	3 Days

MODEL	1-10 UNITS	11-25 UNITS	26-50 UNITS	51+ UNITS
8408	3 Days	5 Days	7 Days	Call
8451	3 Days	5 Days	7 Days	Call
8171-6	3 Days	5 Days	7 Days	Call
8171-175-6	3 Days	5 Days	7 Days	Call
9118-9112	3 Days	5 Days	7 Days	Call
9112-9130	3 Days	5 Days	7 Days	Call
9112-12	3 Days	5 Days	7 Days	Call

* Finish 248 (White) has a 20 day lead time.

Freight Estimate Tool

TOTAL ORDER VALUE OR PRODUCT	Freight Cost: ZONE 3	Freight Cost: ZONE 2	Freight Cost: ZONE 1
Preferred Carriers	UPS Freight	Conway	PA/MD/DC/NJ/Northeast: Pyle Rest of Zone 1: Conway
\$0 - \$499.99	16% of total order value	11% of total order value	7% of total order value
\$500 - \$2,999.99	13% of total order value	8% of total order value	6% of total order value
\$3000 +	9% of total order value	7% of total order value	5% of total order value
Winston Desks	\$29 per unit	\$29 per unit	\$29 per unit
Winston / Winston-E 1 & 2	\$42 per unit	\$42 per unit	\$37 per unit
Winston / Winston-E 3 & 4	\$47 per unit	\$53 per unit	\$47 per unit
One Touch	\$121 per unit	\$74 per unit	\$58 per unit

For LTL shipments - please call for quote

Freight Charges are calculated on a per shipment release value, not total order value:
 (e.g.: a \$20K order shipping 20 releases of \$1k each is calculated on each shipment release/invoice at the respective \$1K release value freight cost %)

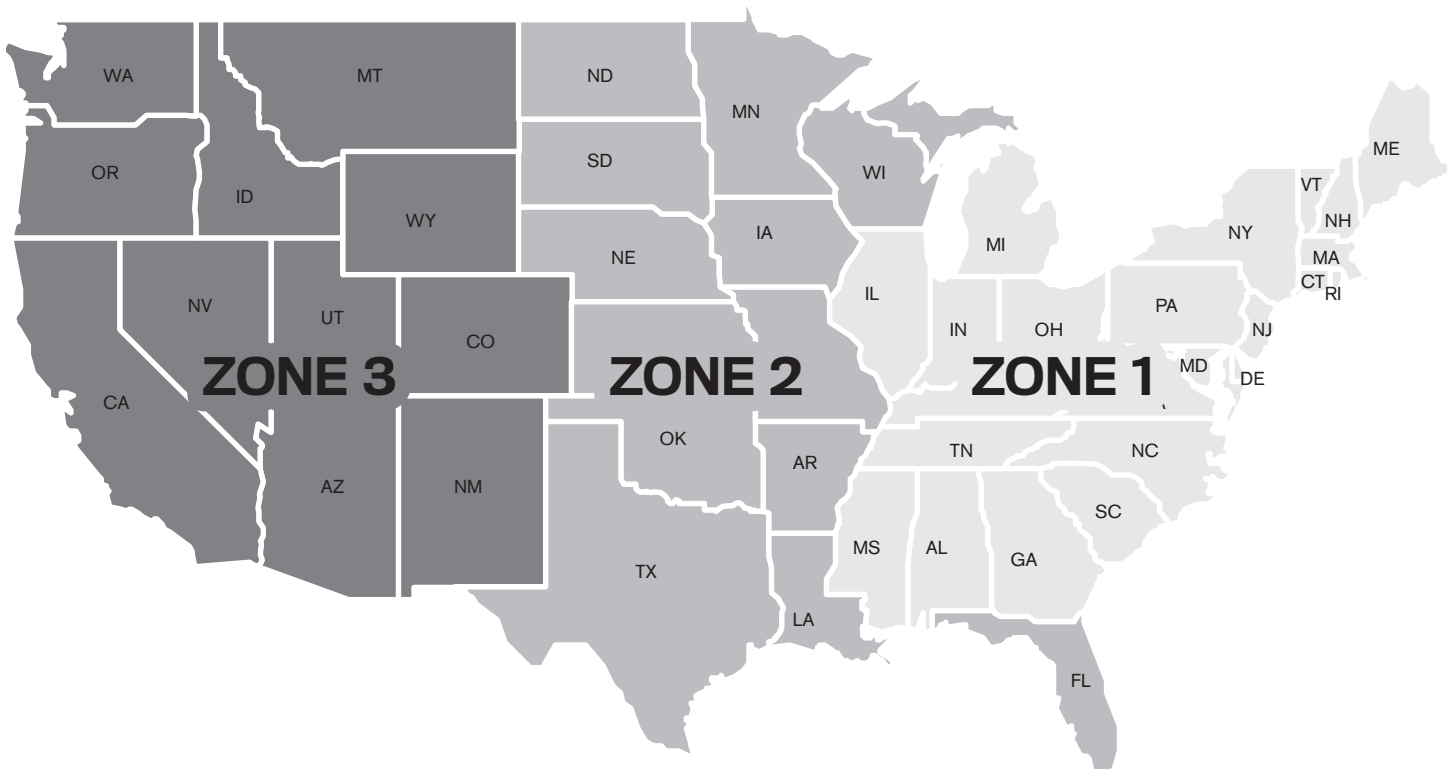

Winston E-Desk®

The Winston E-Desk features programmable memory, a spacious worksurface and optional beam mounts.

MODEL		FINISHES	LIST PRICE
WNSTE-DESK		Black, White	\$1,261
INCLUDES	VERTICAL RANGE	HORIZONTAL RANGE	REQUIRED TO SPECIFY
Height adjustable desk, supports up to 45 lbs.	1.5" - 20.5"	N/A	Model (ie.WNSTE-DESK-BLK)

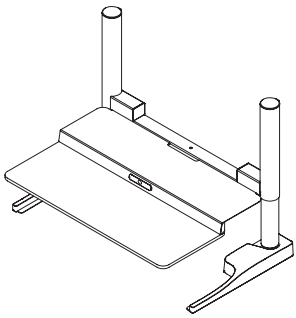

Winston-E® Single w/Compact Work Surface

Features a compact work surface, ideal for users with smaller spaces who want to take advantage of a healthy sit stand workstation.

MODEL	FINISHES		LIST PRICE
WNSTE-1-CW (Supports up to 40 lbs)	270 (Gray Duotone)		\$1,778
INCLUDES	VERTICAL RANGE	HORIZONTAL RANGE	REQUIRED TO SPECIFY
Winston-E with compact work surface, freestanding mount and 75/100mm VESA adapter.	18.4"	N/A	Model, Finish (ie. WNSTE-1-CW-270)

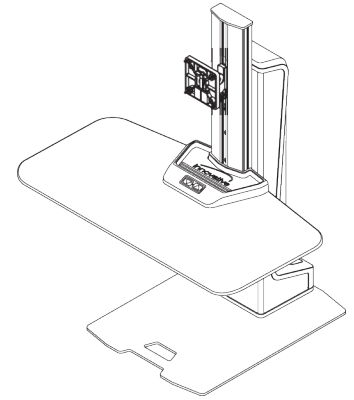

Winston-E® Dual w/Compact Work Surface

Features a compact work surface, ideal for users with smaller spaces who want to take advantage of a healthy sit stand workstation.

MODEL	FINISHES		LIST PRICE
WNSTE-2-CW (Supports up to 40 lbs)	270 (Gray Duotone)		\$1,976
INCLUDES	VERTICAL RANGE	HORIZONTAL RANGE	REQUIRED TO SPECIFY
Winston-E with compact work surface, freestanding mount and 75/100mm VESA adapters.	18.4"	N/A	Model, Finish (ie. WNSTE-2-CW-270)

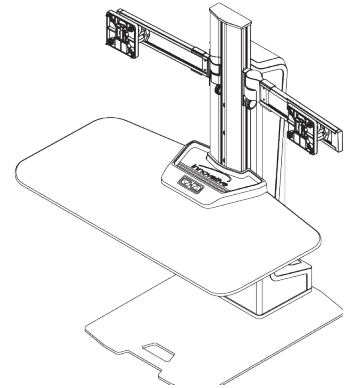

Winston-E® Triple w/Compact Work Surface

Features a compact work surface, ideal for users with smaller spaces who want to take advantage of a healthy sit stand workstation.

MODEL	FINISHES		LIST PRICE
WNSTE-3-CW (Supports up to 40 lbs)	270 (Gray Duotone)		\$2,137
INCLUDES	VERTICAL RANGE	HORIZONTAL RANGE	REQUIRED TO SPECIFY
Winston-E with compact work surface, freestanding mount and 75/100mm VESA adapters.	18.4"	N/A	Model, Finish (ie. WNSTE-3-CW-270)

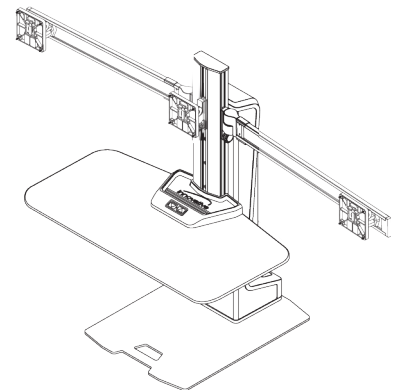

Winston-E® Single

Winston-E Sit-Stand Workstation with a single monitor mount. With the touch of a button, power between sitting and standing. Winston-E makes it easier than ever to incorporate standing into the workday for increased health and productivity.

MODEL	FINISHES	LIST PRICE
WNSTE-1 (Supports up to 40 lbs)	270 (Gray Duotone)	\$1,778

INCLUDES	VERTICAL RANGE	HORIZONTAL RANGE	REQUIRED TO SPECIFY
Winston-E with freestanding mount and 75/100mm VESA adapter.	18.4"	N/A	Model, Finish (ie. WNSTE-1-270)

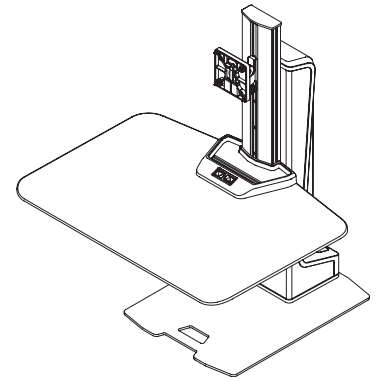

Winston-E® Dual

Winston-E Sit-Stand Workstation with a dual monitor mount. With the touch of a button, power between sitting and standing. Features focal depth and independent monitor height adjustments.

MODEL	FINISHES	LIST PRICE
WNSTE-2 (Supports up to 40 lbs)	270 (Gray Duotone)	\$1,976

INCLUDES	VERTICAL RANGE	HORIZONTAL RANGE	REQUIRED TO SPECIFY
Winston-E with freestanding mount and 75/100mm VESA adapters.	18.4"	N/A	Model, Finish (ie. WNSTE-2-270)

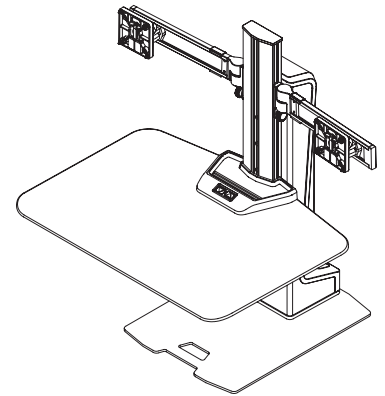

Winston-E® Triple

Winston-E Sit-Stand Workstation with a triple monitor mount. With the touch of a button, power between sitting and standing. Features focal depth and independent monitor height adjustments.

MODEL	FINISHES	LIST PRICE
WNSTE-3 (Supports up to 40 lbs)	270 (Gray Duotone)	\$2,137

INCLUDES	VERTICAL RANGE	HORIZONTAL RANGE	REQUIRED TO SPECIFY
Winston-E with freestanding mount and 75/100mm VESA adapters.	18.4"	N/A	Model, Finish (ie. WNSTE-3-270)

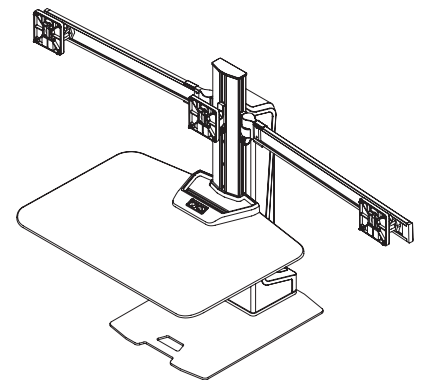

Winston Workstation® Single Compact

Winston Workstation® now comes with a compact work surface, ideal for users with smaller spaces who want to take advantage of a healthy sit stand workstation.

MODEL	FINISHES	LIST PRICE
WNST-1-CW (Supports 7-20 lbs)	104 (Black), 124 (Silver)	\$1,197

INCLUDES	VERTICAL RANGE	HORIZONTAL RANGE	REQUIRED TO SPECIFY
Winston with freestanding mount. 75/100mm VESA adapter.	18.4" surface to surface	N/A	Model, Finish (ie. WNST-1-124)

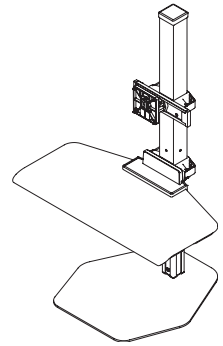

Winston Workstation® Dual Compact

MODEL	FINISHES	LIST PRICE
WNST-2-CW (Supports 10-26 lbs)	104 (Black), 124 (Silver)	\$1,261

INCLUDES	VERTICAL RANGE	HORIZONTAL RANGE	REQUIRED TO SPECIFY
Winston with freestanding mount. 75/100mm VESA adapters.	18.4" surface to surface	N/A	Model, Finish (ie. WNST-2-124)

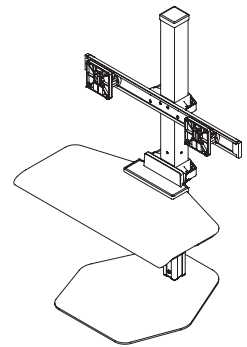

Winston Workstation® Triple Compact

MODEL	FINISHES	LIST PRICE
WNST-3-CW (Supports 15-36 lbs)	104 (Black), 124 (Silver)	\$1,507

INCLUDES	VERTICAL RANGE	HORIZONTAL RANGE	REQUIRED TO SPECIFY
Winston with freestanding mount. 75/100mm VESA adapters.	18.4" surface to surface	N/A	Model, Finish (ie. WNST-3-124)

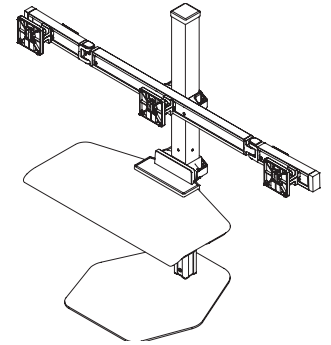

Winston Workstation® Quad Compact

(Special order only)

MODEL	FINISHES	LIST PRICE
WNST-4-CW (Supports 24-40 lbs)	104 (Black), 124 (Silver)	\$1,876

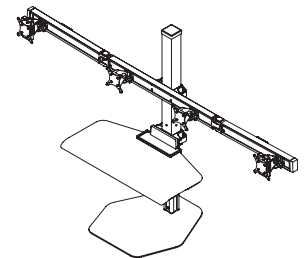

Winston Workstation® Laptop Holder

MODEL	FINISHES	LIST PRICE
8501	104 (Black), 124 (Silver)	\$396

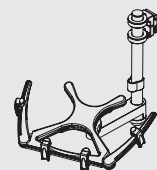

Winston Workstation® Single

Winston Workstation freestanding sit-stand supports a flat panel monitor and features push-button height adjustment.

MODEL	FINISHES		LIST PRICE
WNST-1 (Supports 7-20 lbs)	104 (Black), 124 (Silver), 248 (White)		\$1,197
INCLUDES	VERTICAL RANGE	HORIZONTAL RANGE	REQUIRED TO SPECIFY
Winston with freestanding mount. 75/100mm VESA adapter.	18.4" surface to surface	N/A	Model, Finish (ie. WNST-1-124)

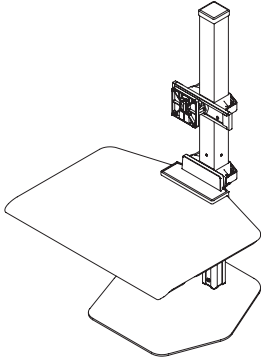

Winston Workstation® Dual

Winston Workstation freestanding sit-stand supports two flat panel monitors and features push-button height adjustment.

MODEL	FINISHES		LIST PRICE
WNST-2 (Supports 10-26 lbs)	104 (Black), 124 (Silver), 248 (White)		\$1,261
INCLUDES	VERTICAL RANGE	HORIZONTAL RANGE	REQUIRED TO SPECIFY
Winston with freestanding mount. 75/100mm VESA adapters.	18.4" surface to surface	N/A	Model, Finish (ie. WNST-2-124)

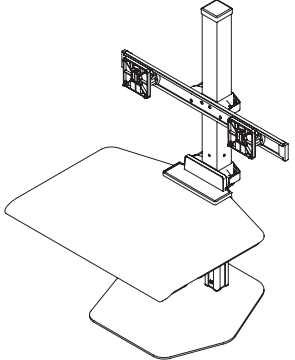

Winston Workstation® Triple

Winston Workstation triple freestanding sit-stand supports a three monitor setup and features push-button height adjustment. Winston Workstation Triple is the industry's only sit-stand workstation to support three monitors.

MODEL	FINISHES		LIST PRICE
WNST-3 (Supports 15-36 lbs)	104 (Black), 124 (Silver), 248 (White)		\$1,507
INCLUDES	VERTICAL RANGE	HORIZONTAL RANGE	REQUIRED TO SPECIFY
Winston with freestanding mount. 75/100mm VESA adapters.	18.4" surface to surface	N/A	Model, Finish (ie. WNST-3-124)

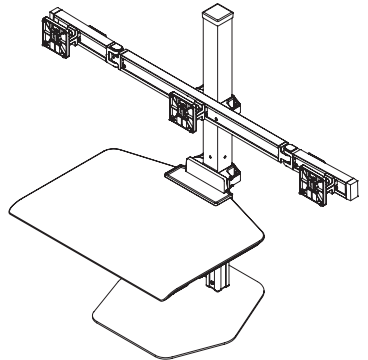

Winston Workstation® Quad

(Special order only)

Winston Workstation quad freestanding sit-stand supports a four monitor setup and features push-button height adjustment. Winston Workstation Quad is the only sit-stand workstation to mount four monitors.

MODEL	FINISHES		LIST PRICE
WNST-4 (Supports 24-40 lbs)	104 (Black), 124 (Silver), 248 (White)		\$1,876

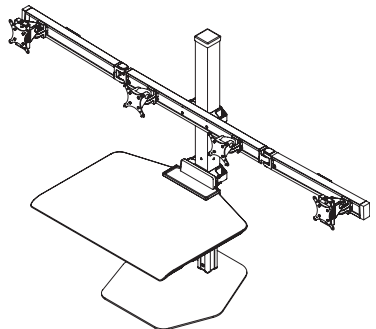

One Touch Single

The One Touch system is an electric powered sit-stand workstation that retrofits to your existing desk, making it compatible with any type of setup!

MODEL	FINISHES	LIST PRICE
1TCH-1 (Up to a 25 lb. monitor, 100 lbs. total)	BLK (Black), SLV (Silver)	\$2,192

INCLUDES	VERTICAL RANGE	HORIZONTAL RANGE	REQUIRED TO SPECIFY
Sit-stand workstation with clamp & rail mount, 75/100mm VESA adapters.	20"	N/A	Model (ie. 1TCH-1-SLV)

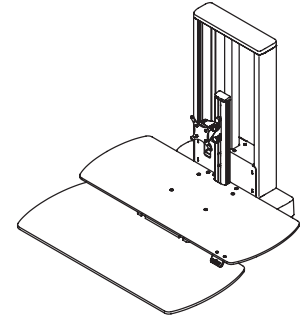

One Touch Dual

The One Touch system is an electric powered sit-stand workstation that retrofits to your existing desk, making it compatible with any type of setup!

MODEL	FINISHES	LIST PRICE
1TCH-2 (Up to 15 lbs. per monitor, 100 lbs. total)	BLK (Black), SLV (Silver)	\$2,682

INCLUDES	VERTICAL RANGE	HORIZONTAL RANGE	REQUIRED TO SPECIFY
Sit-stand workstation with clamp & rail mount, 75/100mm VESA adapters.	20"	N/A	Model (ie. 1TCH-3-SLV)

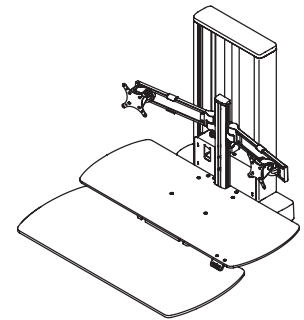

One Touch Triple

The One Touch system is an electric powered sit-stand workstation that retrofits to your existing desk, making it compatible with any type of setup!

MODEL	FINISHES	LIST PRICE
1TCH-3 (Up to 15 lbs. per monitor on wing, up to a 25 lb. monitor on column, 100 lbs. total)	BLK (Black), SLV (Silver)	\$2,796

INCLUDES	VERTICAL RANGE	HORIZONTAL RANGE	REQUIRED TO SPECIFY
Sit-stand workstation with clamp & rail mount, 75/100mm VESA adapters.	20"	N/A	Model (ie. 1TCH-3-SLV)

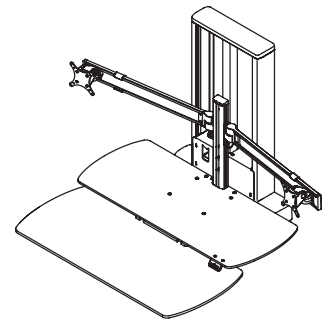

One Touch One over One

The One Touch system is an electric powered sit-stand workstation that retrofits to your existing desk, making it compatible with any type of setup!

MODEL	FINISHES	LIST PRICE
1TCH-1/1 (Up to a 25 lb. monitor, 100 lbs. total)	BLK (Black), SLV (Silver)	\$2,950

INCLUDES	VERTICAL RANGE	HORIZONTAL RANGE	REQUIRED TO SPECIFY
Sit-stand workstation with clamp & rail mount, 75/100mm VESA adapters.	20"	N/A	Model (ie. 1TCH-1/1-SLV)

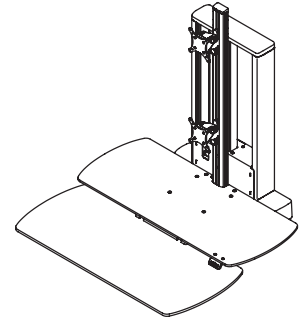

One Touch Two over Two

The One Touch system is an electric powered sit-stand workstation that retrofits to your existing desk, making it compatible with any type of setup!

MODEL	FINISHES	LIST PRICE
1TCH-2/2 (Up to 15 lbs. per monitor, 100 lbs. total)	BLK (Black), SLV (Silver)	\$3,251

INCLUDES	VERTICAL RANGE	HORIZONTAL RANGE	REQUIRED TO SPECIFY
Sit-stand workstation with clamp & rail mount, 75/100mm VESA adapters.	20"	N/A	Model (ie. 1TCH-2/2-SLV)

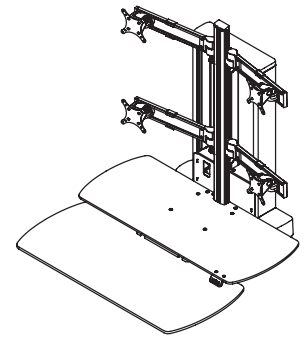

One Touch Three over Three

The One Touch system is an electric powered sit-stand workstation that retrofits to your existing desk, making it compatible with any type of setup!

MODEL	FINISHES	LIST PRICE
1TCH-3/3 (Up to 15 lbs. per monitor on wing, up to a 25 lbs. monitor on column, 100 lbs. total)	BLK (Black), SLV (Silver)	\$3,587

INCLUDES	VERTICAL RANGE	HORIZONTAL RANGE	REQUIRED TO SPECIFY
Sit-stand workstation with clamp & rail mount, 75/100mm VESA adapters.	20"	N/A	Model (ie. 1TCH-3/3-SLV)

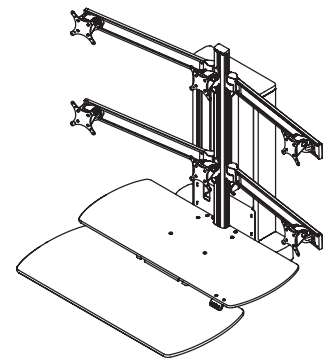

Envoy™

Envoy is an affordable yet powerful articulating arm with effortless one-touch monitor adjustment.

MODEL	CYLINDER	FINISHES	LIST PRICE
Envoy-1	N/A (Supports a 2.2 - 19.8 lbs monitor)	SLV (Silver)	\$303

INCLUDES	VERTICAL RANGE	HORIZONTAL RANGE	REQUIRED TO SPECIFY
Arm with quick install tilter. 75/100mm VESA adapter. Desk clamp or bolt thru-mount.	13.2"	23.7"	Model, Finish (ie. ENVOY-1-SLV)

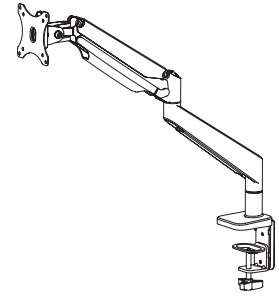

Dual Envoy™

The Dual Envoy is an affordable yet powerful articulating arm with effortless one-touch monitor adjustment.

MODEL	CYLINDER	FINISHES	LIST PRICE
Envoy-2	N/A (Supports 2.2 - 19.8 lbs per monitor)	BLK (Black), SLV (Silver)	\$581

INCLUDES	VERTICAL RANGE	HORIZONTAL RANGE	REQUIRED TO SPECIFY
(2) arms with quick install tilters. 75/100mm VESA adapters. Desk clamp or bolt thru-mount.	13.2"	23.7"	Model, Finish (ie. ENVOY-2-SLV)

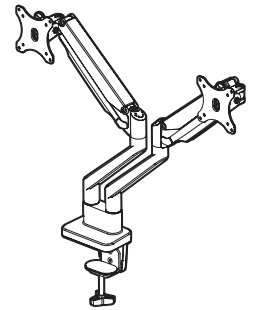

E2 Single

With a fast and easy install, quick release tilter and featured sliders on the dual arm, the E2 proves to be the ideal monitor arm for both home and office environments.

MODEL	CYLINDER	FINISHES	LIST PRICE
E2-1	Flat monitor: Supports 2.2 - 19 lbs., Curved monitor: Up to 16 lbs.	104 (Black), 124 (Silver), 248 (White)	\$322

INCLUDES	VERTICAL RANGE	HORIZONTAL RANGE	REQUIRED TO SPECIFY
Desk clamp or grommet mount.	13.3"	20.6"	Model, Finish (ie. E2-1-104)

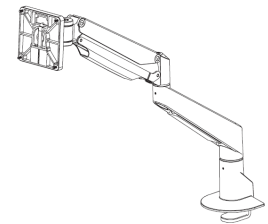

E2 Dual

With a fast and easy install, quick release tilter and featured sliders on the dual arm, the E2 proves to be the ideal monitor arm for both home and office environments.

MODEL	WEIGHT CAPACITY	FINISHES	LIST PRICE
E2-2	Flat monitor: Supports 2.2 - 19 lbs. per monitor. Curved monitor: Up to 16 lbs.	104 (Black), 124 (Silver), 248 (White)	\$598

INCLUDES	VERTICAL RANGE	HORIZONTAL RANGE	REQUIRED TO SPECIFY
Desk clamp or grommet mount.	13"	18.5"	Model, Finish (ie. E2-2-104)

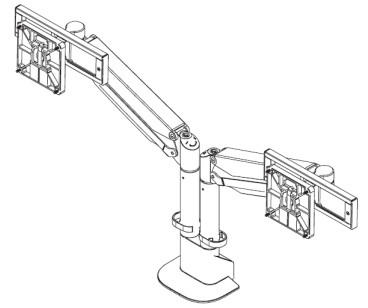

E2 Connex Single

MODEL	WEIGHT CAPACITY	FINISHES	LIST PRICE
E2-01-SD	Flat monitor: 2.2 - 20 lbs. Curved monitor: Up to 16 lbs	104 (Black), 124 (Silver), 248 (White)	\$475

INCLUDES	VERTICAL RANGE	HORIZONTAL RANGE	REQUIRED TO SPECIFY
Desk clamp or grommet mount.	13"	23"	Model, Finish (ie. E2-01-SD-104)

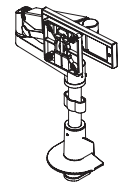

E2 Connex Dynamic Dual

MODEL	WEIGHT CAPACITY	FINISHES	LIST PRICE
E2-02-D	2.2 - 20 lbs. per monitor	104 (Black), 124 (Silver), 248 (White)	\$839

INCLUDES	VERTICAL RANGE	HORIZONTAL RANGE	REQUIRED TO SPECIFY
Desk clamp or grommet mount.	13"	16"	Model, Finish (ie. E2-02-D-104)

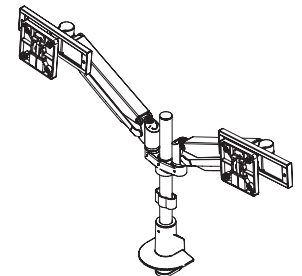

E2 Connex Dynamic Dual Wide

MODEL	WEIGHT CAPACITY	FINISHES	LIST PRICE
E2-02-SD	2.2 - 20 lbs. per monitor	104 (Black), 124 (Silver), 248 (White)	\$964

INCLUDES	VERTICAL RANGE	HORIZONTAL RANGE	REQUIRED TO SPECIFY
Desk clamp or grommet mount.	13"	19.5"	Model, Finish (ie. E2-02-SD-104)

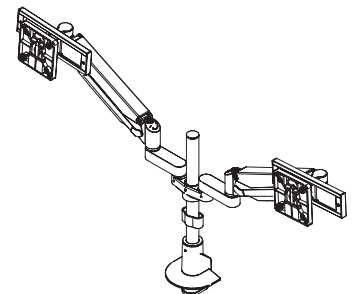

E2 Connex Dynamic Triple

MODEL	WEIGHT CAPACITY	FINISHES	LIST PRICE
E2-03-SD	2.2 - 20 lbs. per monitor	104 (Black), 124 (Silver), 248 (White)	\$1,082

INCLUDES	VERTICAL RANGE	HORIZONTAL RANGE	REQUIRED TO SPECIFY
Desk clamp or grommet mount.	13"	28.5"	Model, Finish (ie. E2-03-SD-104)

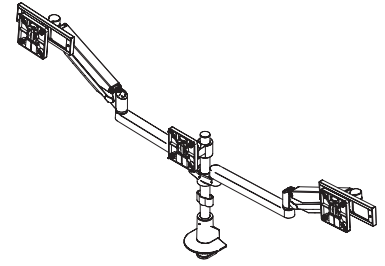

E2 Connex Static Dual

MODEL	WEIGHT CAPACITY	FINISHES	LIST PRICE
E2-02-SS	2.2 - 20 lbs. per monitor	104 (Black), 124 (Silver), 248 (White)	\$724

INCLUDES	VERTICAL RANGE	HORIZONTAL RANGE	REQUIRED TO SPECIFY
Desk clamp or grommet mount.	-	18.5"	Model, Finish (ie. E2-02-SS-104)

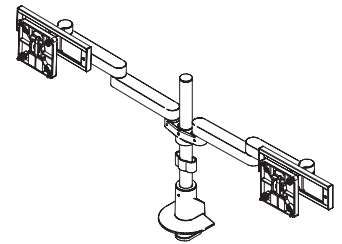

E2 Connex Static Triple

MODEL	WEIGHT CAPACITY	FINISHES	LIST PRICE
E2-03-SSS	2.2 - 20 lbs. per monitor	104 (Black), 124 (Silver), 248 (White)	\$852

INCLUDES	VERTICAL RANGE	HORIZONTAL RANGE	REQUIRED TO SPECIFY
Desk clamp or grommet mount.	-	28.5"	Model, Finish (ie. E2-03-SSS-104)

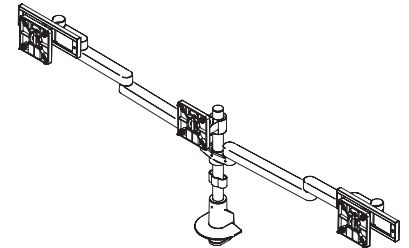

E2 Connex One Over One

MODEL	WEIGHT CAPACITY	FINISHES	LIST PRICE
E2-11-HD	Flat monitors: Up to 40 lbs. per monitor Curved monitors: 0 - 26.5 lbs. per monitor	104 (Black), 124 (Silver), 248 (White)	\$334

INCLUDES	VERTICAL RANGE	HORIZONTAL RANGE	REQUIRED TO SPECIFY
Desk clamp or grommet mount.	-	-	Model, Finish (ie. E2-11-HD-104)

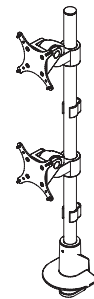

7000

Our best-selling 7000 monitor arm suspends your flat panel monitor above your desk, allowing for easy repositioning with just one hand. This articulating monitor mount enables you to reclaim your desk top while you work in greater ergonomic comfort.

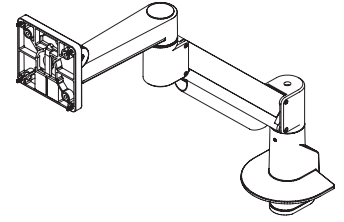

MODEL	CYLINDER	FINISHES	LIST PRICE
7000	500 (Flat Panel: 10 - 22 lbs. Curved monitor: Up to 22 lbs)	104 (Black), 124 (Silver), 248 (White)	\$410
7000	800 (Flat Panel: 10 - 22 lbs. Curved monitor: Up to 22 lbs)	104 (Black), 124 (Silver), 248 (White)	\$410
7000	1000 (Flat Panel: 13 - 28 lbs. Curved monitor: Up to 22 lbs)	104 (Black), 124 (Silver), 248 (White)	\$410

INCLUDES	VERTICAL RANGE	HORIZONTAL RANGE	REQUIRED TO SPECIFY
Arm with 75/100mm VESA adapter. FLEXmount™-offers six mounting options.	16.0"	24.0"	Model, Cylinder, Finish (ie. 7000-500-124)

7000-2

Our best-selling 7000 monitor arm in a productivity-enhancing dual monitor mount.

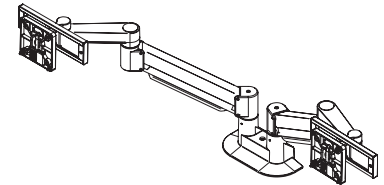

MODEL	CYLINDER	FINISHES	LIST PRICE
7000-2-XXX-SLD	500 (3 - 10 lbs. per monitor)	104 (Black), 124 (Silver), 248 (White)	\$800
7000-2-XXX-SLD	800 (10 - 22 lbs. per monitor)	104 (Black), 124 (Silver), 248 (White)	\$800

INCLUDES	VERTICAL RANGE	HORIZONTAL RANGE	REQUIRED TO SPECIFY
Dual mount with (2) 7000 Series arms and 75/100mm VESA adapters, 2 sliders.	16.0"	24.0"	Model, Cylinder, Finish (ie. 7000-2-500-SLD-124)

7000 Dual Crossbar

Our best-selling 7000 monitor arm combined with our dual monitor bracket.

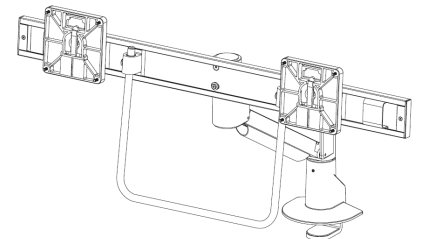

MODEL	CYLINDER	FINISHES	LIST PRICE
7000-1-8537H	1000 (6 - 14 lbs. per monitor)	104 (Black), 124 (Silver), 248 (White)	\$562

INCLUDES	VERTICAL RANGE	HORIZONTAL RANGE	REQUIRED TO SPECIFY
7000 Series arm with crossbar, Top down mount	16.0"	24.0"	Model, Finish (ie. 7000-1-7537H-124)

7000-Switch™

Our best-selling 7000 monitor arm combined with our dual monitor bracket.

MODEL	CYLINDER	FINISHES	LIST PRICE
7000-SWITCH	1000 (Supports 3.5 - 13 lbs per monitor)	104 (Black), 124 (Silver), 248 (White)	\$596

INCLUDES	VERTICAL RANGE	HORIZONTAL RANGE	REQUIRED TO SPECIFY
7000 Series arm with dual monitor bracket. 75/100mm VESA quick-release adapters and topdown mount.	16.0"	24.0"	Model, Cylinder, Finish (ie. 7000-SWITCH-1000-124)

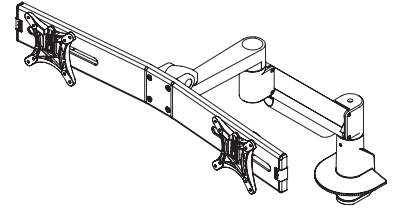

7500

The flagship 7500 monitor arm is the world's best mount for large screens and dual screens, offering precision engineering, attractive design and extreme ease of use. The 7500 desk monitor mount features our patented HD tilter, a spring-assisted pivot for the monitor which makes adjustments remarkably easy, even with larger screens.

MODEL	CYLINDER	FINISHES	LIST PRICE
7500	500 (Supports monitors 2 - 13 lbs)	104 (Black), 124 (Silver), 248 (White)	\$626
7500	800 (Supports monitors 6 - 21 lbs)	104 (Black), 124 (Silver), 248 (White)	\$626
7500	1000 (Supports monitors 8 - 27 lbs)	104 (Black), 124 (Silver), 248 (White)	\$626
7500	1500 (Supports monitors 12 - 40 lbs)	104 (Black), 124 (Silver), 248 (White)	\$626

INCLUDES	VERTICAL RANGE	HORIZONTAL RANGE	REQUIRED TO SPECIFY
Heavy duty arm with 75/100mm VESA adapter. FLEXmount™-offers six mounting options.	18.0"	27.0"	Model, Cylinder, Finish (ie. 7500-500-124)

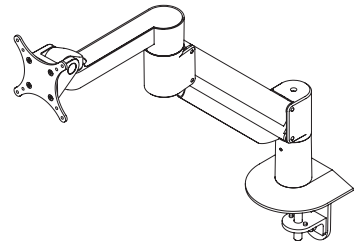

7500-Wing

Our heavy duty 7500 monitor arm combined with our dual monitor bracket.

MODEL	CYLINDER	FINISHES	LIST PRICE
7500-WING	1000 (Supports 1 - 11.4 lbs per monitor)	104 (Black), 124 (Silver), 248 (White)	\$909
7500-WING	1500 (Supports 2.5 - 18.7 lbs per monitor)	104 (Black), 124 (Silver), 248 (White)	\$909

INCLUDES	VERTICAL RANGE	HORIZONTAL RANGE	REQUIRED TO SPECIFY
Heavy duty arm with dual monitor bracket. 75/100mm VESA quick-release adapters and FLEXmount™.	18.0"	27.0"	Model, Cylinder, Finish (ie. 7500-WING-1000-124)

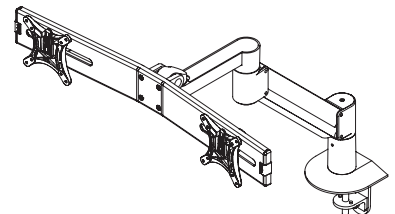

7000-T

Combined with our best-selling 7000 arm, the 7000-T allows users to create an instant height adjustable docking station for their laptop.

MODEL	CYLINDER	FINISHES	LIST PRICE
7000-T-500HY	N/A (Supports laptops 1-14 lbs)	104 (Black), 124 (Silver), 248 (White)	\$497
INCLUDES	VERTICAL RANGE	HORIZONTAL RANGE	REQUIRED TO SPECIFY
Arm, laptop holder, and topdown mount.	16.0"	24.0"	Model, Finish (ie. 7000-T-500HY-124)

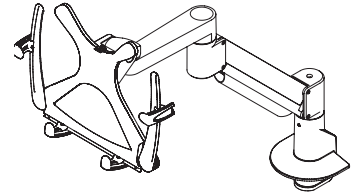

7050

The 7050 height adjustable laptop and monitor arm allows mobile workers to combine their notebook with a full-size monitor for enhanced productivity.

MODEL	CYLINDER	FINISHES	LIST PRICE
7050	500-500SR (Supports a 2 - 13 lb monitor and a 3 - 13.5 lb laptop)	104 (Black), 124 (Silver), 248 (White)	\$1,017
7050	800-500SR (Supports a 7.5 - 25 lb monitor and a 3 - 13.5 lb laptop)	104 (Black), 124 (Silver), 248 (White)	\$1,017
7050	1000-500SR (Supports a 12 - 31 lb monitor and a 3 - 13.5 lb laptop)	104 (Black), 124 (Silver), 248 (White)	\$1,017
INCLUDES	VERTICAL RANGE	HORIZONTAL RANGE	REQUIRED TO SPECIFY
Dual mount with (1) 7000 arm, (1) 7045 arm, 75/100mm VESA adapters and laptop holder.	16.0"	24.0"	Model, Cylinder, Finish (ie. 7050-500-500SR-124)

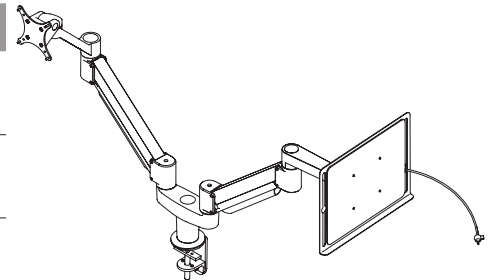

7050-Switch

Dual mount with dual monitor bracket and laptop holder.

MODEL	CYLINDER	FINISHES	LIST PRICE
7050-SWITCH	1000-500SR (Supports 3.5 - 13 lbs per monitor and a 3 - 13.5 lbs laptop)	104 (Black), 124 (Silver)	\$1,153
INCLUDES	VERTICAL RANGE	HORIZONTAL RANGE	REQUIRED TO SPECIFY
Dual mount with (1) 7000 arm, (1) 7045 arm, dual monitor bracket with 75/100mm VESA quick-release adapters and laptop holder.	16.0"	24.0"	Model, Cylinder, Finish (ie. 7050-SWITCH-1000-500SR-124)

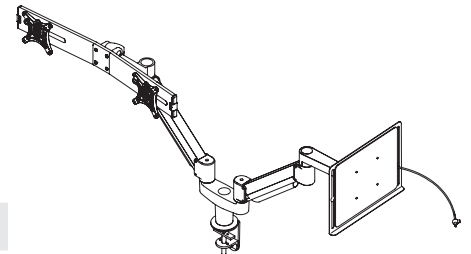

Staxx™ Single

Mount one monitor with Staxx.

MODEL	SUPPORTS	FINISHES	LIST PRICE
STX-01S	Supports up to 30 lbs, 50" and under	104 (Black), 124 (Silver), 248 (White)	\$298

INCLUDES	HEIGHT ADJUST	REQUIRED TO SPECIFY
Single tier pole arm w/14" pole, 75/100mm VESA adapters and desk clamp mount.	1" increments of monitor height adjust on poles.	Model, Finish (ie. STX-01S-104)

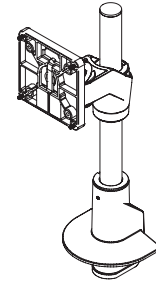

Staxx™ Dual

Mount two monitors side-by-side with Staxx Dual.

MODEL	SUPPORTS	FINISHES	LIST PRICE
STX-02S	Supports up to 20 lbs per monitor, 24" & under	104 (Black), 124 (Silver), 248 (White)	\$678

STX-02W	Supports up to 20 lbs per monitor, 24" - 30"	104 (Black), 124 (Silver), 248 (White)	\$748
---------	--	--	-------

INCLUDES	HEIGHT ADJUST	REQUIRED TO SPECIFY
Single tier pole arm w/14" pole, 75/100mm VESA adapters and topdown mount.	1" increments of monitor height adjust on poles.	Model, Finish (ie. STX-02S-104)

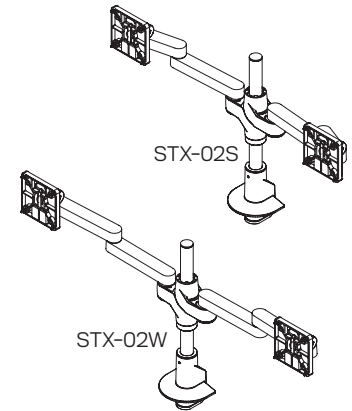

Staxx™ Triple

The Staxx triple monitor stands suspends three monitors above your desk.

MODEL	SUPPORTS	FINISHES	LIST PRICE
STX-03S	Supports up to 15 lbs per monitor, 24" & under	104 (Black), 124 (Silver), 248 (White)	\$807

STX-03W	Supports up to 15 lbs per monitor, 24" - 30"	104 (Black), 124 (Silver), 248 (White)	\$860
---------	--	--	-------

INCLUDES	HEIGHT ADJUST	REQUIRED TO SPECIFY
Single tier pole arm w/14" pole, 75/100mm VESA adapters and topdown mount.	1" increments of monitor height adjust on poles.	Model, Finish (ie. STX-03S-104)

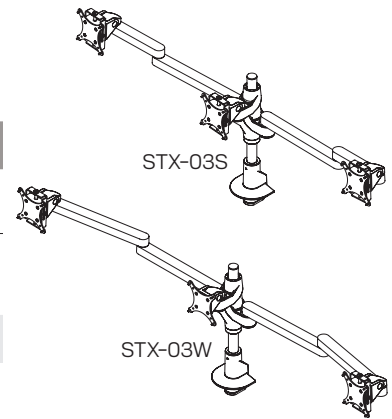

Staxx™ 1 over 1

Mount two monitors vertically with Staxx 1 over 1.

MODEL	SUPPORTS	FINISHES	LIST PRICE
STX-11S	Supports up to 20 lbs per monitor, 30" & under	104 (Black), 124 (Silver), 248 (White)	\$782

INCLUDES	HEIGHT ADJUST	REQUIRED TO SPECIFY
Dual tier pole arm w/28" pole, 75/100mm VESA adapters and topdown mount.	1" increments of monitor height adjust on poles.	Model, Finish (ie. STX-11S-104)

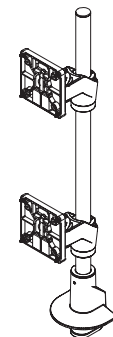

Staxx™ 2 over 2

The multi-monitor stand mounts four monitors—two rows of two monitors side-by-side.

MODEL	SUPPORTS	FINISHES	LIST PRICE
STX-22S	Supports up to 15 lbs per monitor, 24" & under	104 (Black), 124 (Silver), 248 (White)	\$920

STX-22W	Supports up to 15 lbs per monitor, 24" - 30"	104 (Black), 124 (Silver), 248 (White)	\$952
---------	--	--	-------

INCLUDES	HEIGHT ADJUST	REQUIRED TO SPECIFY
Dual tier pole arm w/28" pole, 75/100mm VESA adapters and topdown mount.	1" increments of monitor height adjust on poles.	Model, Finish (ie. STX-22S-104)

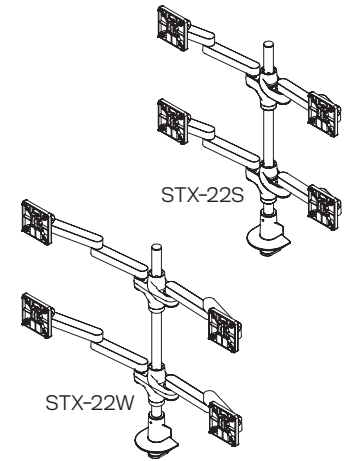

Staxx™ 3 over 3

The multi-monitor stand mounts six monitors—two rows of three monitors side-by-side.

MODEL	SUPPORTS	FINISHES	LIST PRICE
STX-33S	Supports up to 10 lbs per monitor, 24" & under	104 (Black), 124 (Silver), 248 (White)	\$1,358

STX-33W	Supports up to 10 lbs per monitor, 24" - 30"	104 (Black), 124 (Silver), 248 (White)	\$1,410
---------	--	--	---------

INCLUDES	HEIGHT ADJUST	REQUIRED TO SPECIFY
Dual tier pole arm w/28" pole, 75/100mm VESA adapters and topdown mount.	1" increments of monitor height adjust on poles.	Model, Finish (ie. STX-33S-104)

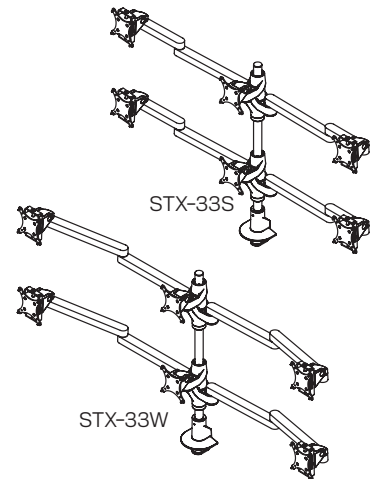

Staxx™ Dual Articulating

Mount two monitors in any position you desire for maximum ergonomic comfort.

MODEL	SUPPORTS	FINISHES	LIST PRICE
STX-450 (*3500 arms)	Supports 10 - 23 lbs per monitor, 27" & under	104 (Black), 124 (Silver), 248 (White)	\$884

STX-500	Supports 2 - 10 lbs per monitor, 27" & under	104 (Black), 124 (Silver), 248 (White)	\$884
---------	--	--	-------

STX-600	Supports 7 - 17 lbs per monitor, 27" & under	104 (Black), 124 (Silver), 248 (White)	\$884
---------	--	--	-------

STX-800	Supports 10 - 22 lbs per monitor, 27" & under	104 (Black), 124 (Silver), 248 (White)	\$884
---------	---	--	-------

STX-1000	Supports 13 - 28 lbs per monitor, 27" & under	104 (Black), 124 (Silver), 248 (White)	\$884
----------	---	--	-------

INCLUDES	HEIGHT ADJUST	VERTICAL RANGE	REQUIRED TO SPECIFY
Single tier pole arm w/14" pole, (2) 7000 series arms, 75/100mm VESA adapters and topdown mount.	1" increments of monitor height adjust on poles.	16" (8" up and down from horizontal)	Model, Finish (ie. STX-600-104)

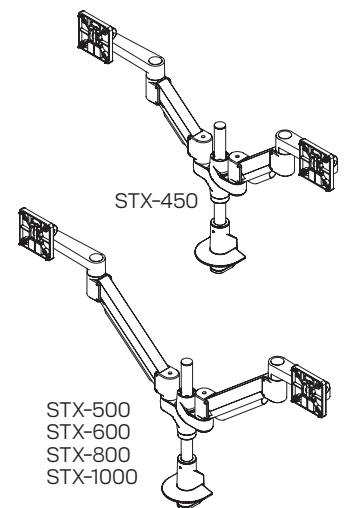

Staxx™ Articulating Monitor + Laptop Mount

Staxx allows you to mount your monitor and laptop in any position you desire.

MODEL	SUPPORTS	FINISHES	LIST PRICE
STX-450-8510 (*3500 arms)	Supports up to 10-23 lb monitor, 27" & under and a 3-13.5 lb laptop	104 (Black), 124 (Silver), 248 (White)	\$1,068
STX-500-8510	Supports up to 3-10 lb monitor, 27" & under and a 3-13.5 lb laptop	104 (Black), 124 (Silver), 248 (White)	\$1,068
STX-600-8510	Supports up to 7 - 17 lb monitor, 27" & under and a 3-13.5 lb laptop	104 (Black), 124 (Silver), 248 (White)	\$1,068
STX-800-8510	Supports up to 10 - 22 lb monitor, 27" & under and a 3-13.5 lb laptop	104 (Black), 124 (Silver), 248 (White)	\$1,068
STX-1000-8510	Supports up to 13 - 28 lb monitor, 27" & under and a 3-13.5 lb laptop	104 (Black), 124 (Silver), 248 (White)	\$1,068

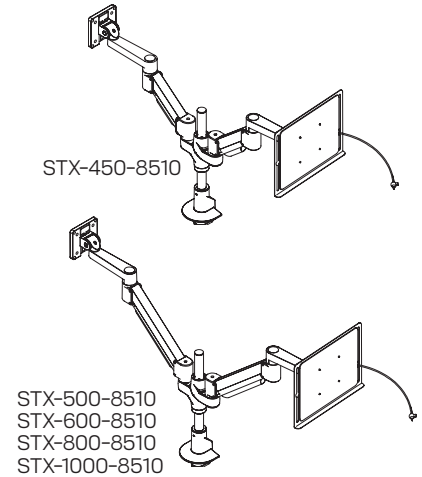

INCLUDES	HEIGHT ADJUST	REQUIRED TO SPECIFY
Single tier pole arm w/14" pole, (2) 7000 series arms, 75/100mm VESA adapters, laptop holder and topdown mount.	1" increments of height adjust on poles.	Model, Finish (ie. STX-500-8510-104)

Staxx™ Stackable Pole Mount Cup

Allows you to expand your Staxx configuration.

MODEL	FINISHES	LIST PRICE
STX-NM	104 (Black), 124 (Silver), 248 (White)	\$95

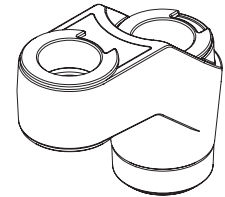

INCLUDES	REQUIRED TO SPECIFY
Staxx™ stackable pole mount cup.	Model, Finish (ie. STX-NM-104)

Bild® Dual

Mount two monitors side-by-side with Bild.

MODEL	MOUNT	FINISHES	LIST PRICE
BILD-2 (Supports up to 30 lbs per monitor)	CM (Clamp Mount)	104 (Black), 124 (Silver)	\$794
BILD-2 (Supports up to 30 lbs per monitor)	TM (Thru-Mount)	104 (Black), 124 (Silver)	\$653
BILD-2 (Supports up to 30 lbs per monitor)	RM (Rail Mount)	104 (Black), 124 (Silver)	\$727

INCLUDES	VERTICAL RANGE	HORIZONTAL RANGE	REQUIRED TO SPECIFY
Bild with static column. 75/100mm VESA adapters.	N/A	N/A	Model, Mount, Finish (ie. BILD-2-CM-124)

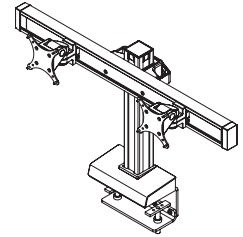

Bild® Triple

Suspend three monitors above your desk – mount monitors flat or in an arch with easy-to-adjust hinges.

MODEL	MOUNT	FINISHES	LIST PRICE
BILD-3 (Supports up to 30 lbs per monitor)	CM (Clamp Mount)	104 (Black), 124 (Silver)	\$1,011
BILD-3 (Supports up to 30 lbs per monitor)	TM (Thru-Mount)	104 (Black), 124 (Silver)	\$702
BILD-3 (Supports up to 30 lbs per monitor)	RM (Rail Mount)	104 (Black), 124 (Silver)	\$943

INCLUDES	VERTICAL RANGE	HORIZONTAL RANGE	REQUIRED TO SPECIFY
Bild with static column. 75/100mm VESA adapters.	N/A	N/A	Model, Mount, Finish (ie. BILD-3-CM-124)

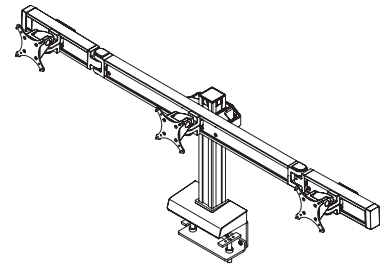

Bild® Quad

The Bild Quad multi-monitor mount easily accommodates four monitors side-by-side.

MODEL	MOUNT	FINISHES	LIST PRICE
BILD-4 (Supports up to 30 lbs per monitor)	CM (Clamp Mount)	104 (Black), 124 (Silver)	\$1,332
BILD-4 (Supports up to 30 lbs per monitor)	TM (Thru-Mount)	104 (Black), 124 (Silver)	\$1,193
BILD-4 (Supports up to 30 lbs per monitor)	RM (Rail Mount)	104 (Black), 124 (Silver)	\$1,265

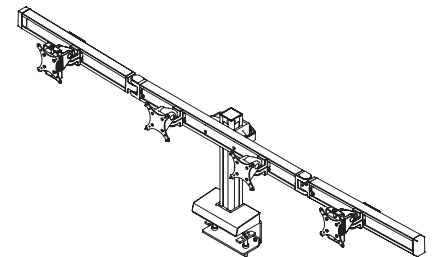

Bild® Mounting Options

Choose from several mounting options.

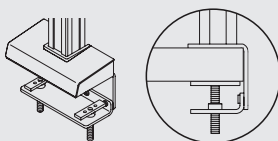

Clamp Mount
Clamps to desks up to 3-inches thick

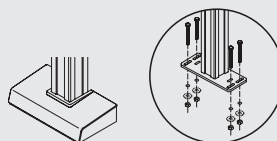

Thru-Mount

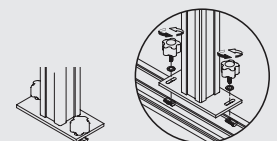

Rail Mount

Bild® 2/2

Bild quad monitor stand mounts four monitors in two rows.

MODEL	MOUNT	FINISHES	LIST PRICE
BILD-2/2 (Supports up to 30 lbs per monitor)	CM (Clamp Mount)	104 (Black), 124 (Silver)	\$1,332
BILD-2/2 (Supports up to 30 lbs per monitor)	TM (Thru-Mount)	104 (Black), 124 (Silver)	\$1,193
BILD-2/2 (Supports up to 30 lbs per monitor)	RM (Rail Mount)	104 (Black), 124 (Silver)	\$1,265

INCLUDES	VERTICAL RANGE	HORIZONTAL RANGE	REQUIRED TO SPECIFY
Bild with static column. 75/100mm VESA adapters.	N/A	N/A	Model, Mount, Finish (ie. BILD-2/2-CM-124)

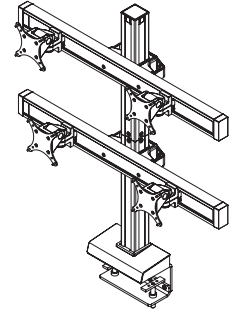

Bild® 3/3

This multi-monitor stand mounts six monitors – two rows of three monitors side-by-side.

MODEL	MOUNT	FINISHES	LIST PRICE
BILD-3/3 (Supports up to 30 lbs per monitor)	CM (Clamp Mount)	104 (Black), 124 (Silver)	\$1,827
BILD-3/3 (Supports up to 30 lbs per monitor)	TM (Thru-Mount)	104 (Black), 124 (Silver)	\$1,689
BILD-3/3 (Supports up to 30 lbs per monitor)	RM (Rail Mount)	104 (Black), 124 (Silver)	\$1,762

INCLUDES	VERTICAL RANGE	HORIZONTAL RANGE	REQUIRED TO SPECIFY
Bild with static column. 75/100mm VESA adapters.	N/A	N/A	Model, Mount, Finish (ie. BILD-3/3-CM-124)

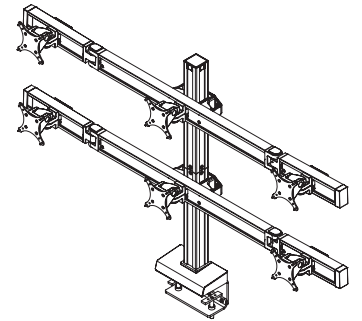

Bild® 4/4

This multi-monitor stand mounts eight monitors – two rows of four monitors side-by-side.

MODEL	MOUNT	FINISHES	LIST PRICE
BILD-4/4 (Supports up to 30 lbs per monitor)	CM (Clamp Mount)	104 (Black), 124 (Silver)	\$2,378
BILD-4/4 (Supports up to 30 lbs per monitor)	TM (Thru-Mount)	104 (Black), 124 (Silver)	\$2,241
BILD-4/4 (Supports up to 30 lbs per monitor)	RM (Rail Mount)	104 (Black), 124 (Silver)	\$2,312

INCLUDES	VERTICAL RANGE	HORIZONTAL RANGE	REQUIRED TO SPECIFY
Bild with static column. 75/100mm VESA adapters.	N/A	N/A	Model, Mount, Finish (ie. BILD-4/4-CM-124)

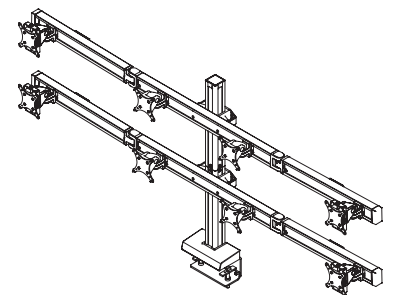

9136-S-14

Reposition articulating monitor arm along the 14" pole mount.

MODEL	FINISHES		LIST PRICE
9136-S-14 (Supports monitors up to 45 lbs)	104 (Black), 124 (Silver), 248 (White)		\$228
INCLUDES	VERTICAL RANGE	HORIZONTAL RANGE	REQUIRED TO SPECIFY
Single tier pole arm w/14" pole and 75/100mm VESA adapter.	N/A	4.5"	Model, Finish (ie. 9136-S-14-124)

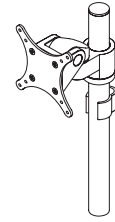

9136-S-14-FM

The 9136-S-14-FM pole mount suspends the flat panel monitor above the work surface.

MODEL	FINISHES		LIST PRICE
9136-S-14-FM (Supports monitors up to 45 lbs)	104 (Black), 124 (Silver), 248 (White)		\$319
INCLUDES	VERTICAL RANGE	HORIZONTAL RANGE	REQUIRED TO SPECIFY
Single tier pole arm w/14" pole and 75/100mm VESA adapter and FLEXmount™.	N/A	4.5"	Model, Finish (ie. 9136-S-14-FM-124)

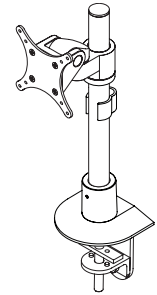

9136-D-28

Reposition articulating monitor arms along the 28" pole mount.

MODEL	FINISHES		LIST PRICE
9136-D-28 (Supports up to 45 lbs per monitor)	104 (Black), 124 (Silver), 248 (White)		\$407
INCLUDES	VERTICAL RANGE	HORIZONTAL RANGE	REQUIRED TO SPECIFY
Dual tier pole arm w/28" pole and 75/100mm VESA adapters.	N/A	4.5"	Model, Finish (ie. 9136-D-28-124)

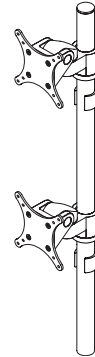

9136-D-28-FM

The 9136-D-28-FM pole mount suspends two monitors above the work surface.

MODEL	FINISHES		LIST PRICE
9136-D-28-FM (Supports up to 45 lbs per monitor)	104 (Black), 124 (Silver), 248 (White)		\$503
INCLUDES	VERTICAL RANGE	HORIZONTAL RANGE	REQUIRED TO SPECIFY
Dual tier pole arm w/28" pole, 75/100mm VESA adapters and FLEXmount™.	N/A	4.5"	Model, Finish (ie. 9136-D-28-124)

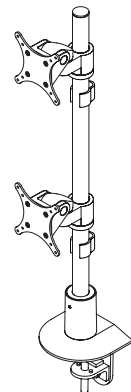

9112-S-14

Easily adjust the monitor arm vertically along the 14" pole mount.

MODEL	FINISHES		LIST PRICE
9112-S-14 (Supports monitors up to 40 lbs)	104 (Black), 124 (Silver)		\$287
INCLUDES	VERTICAL RANGE	HORIZONTAL RANGE	REQUIRED TO SPECIFY
Single tier pole arm w/14" pole and 75/100mm VESA adapter.	N/A	13.1"	Model, Finish (ie. 9112-S-14-124)

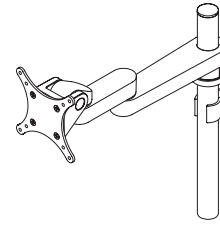

9112-S-14-FM

The 9112-S-14-FM pole mount suspends the flat panel monitor above the work surface.

MODEL	FINISHES		LIST PRICE
9112-S-14-FM (Supports monitors up to 40 lbs)	104 (Black), 124 (Silver)		\$373
INCLUDES	VERTICAL RANGE	HORIZONTAL RANGE	REQUIRED TO SPECIFY
Single tier pole arm w/14" pole and 75/100mm VESA adapter and FLEXmount™.	N/A	13.1"	Model, Finish (ie. 9112-S-14-FM-124)

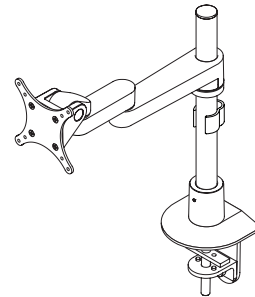

9112-D-28

Easily adjust the monitor arms vertically along the 28" pole mount.

MODEL	FINISHES		LIST PRICE
9112-D-28 (Supports up to 40 lbs per monitor)	104 (Black), 124 (Silver)		\$456
INCLUDES	VERTICAL RANGE	HORIZONTAL RANGE	REQUIRED TO SPECIFY
Dual tier pole arm w/28" pole and 75/100mm VESA adapters.	N/A	13.1"	Model, Finish (ie. 9112-D-28-124)

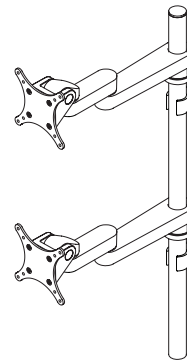

9112-D-28-FM

The 9112-D-28-FM pole mount suspends two monitors above the work surface.

MODEL	FINISHES		LIST PRICE
9112-D-28-FM (Supports up to 40 lbs per monitor)	104 (Black), 124 (Silver)		\$554
INCLUDES	VERTICAL RANGE	HORIZONTAL RANGE	REQUIRED TO SPECIFY
Dual tier pole arm w/28" pole and 75/100mm VESA adapters and FLEXmount™.	N/A	13.1"	Model, Finish (ie. 9112-D-28-FM-124)

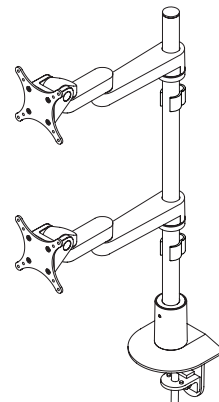

9130-S-14

For increased flexibility, the 9130-S-14 features a 16" monitor arm extension.

MODEL	FINISHES		LIST PRICE
9130-S-14 (Supports monitors up to 40 lbs)	104 (Black), 124 (Silver)		\$327
INCLUDES	VERTICAL RANGE	HORIZONTAL RANGE	REQUIRED TO SPECIFY
Single tier pole arm w/14" pole and 75/100mm VESA adapter.	N/A	16.6"	Model, Finish (ie. 9130-S-14-124)

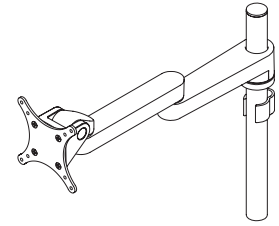

9130-S-14-FM

The 9130-S-14-FM long reach monitor mount features a foldable arm that adjusts vertically up and down along the 14" pole mount.

MODEL	FINISHES		LIST PRICE
9130-S-14-FM (Supports monitors up to 40 lbs)	104 (Black), 124 (Silver)		\$423
INCLUDES	VERTICAL RANGE	HORIZONTAL RANGE	REQUIRED TO SPECIFY
Single tier pole arm w/14" pole, 75/100mm VESA adapter and FLEXmount™.	N/A	16.6"	Model, Finish (ie. 9130-S-14-FM-124)

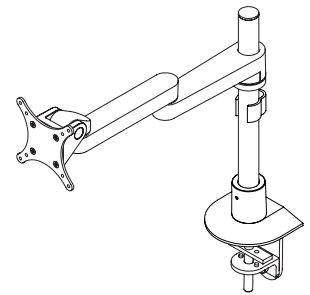

9130-D-28

For increased flexibility, the 9130-D-14 features two 16" monitor arm extensions.

MODEL	FINISHES		LIST PRICE
9130-D-28 (Supports up to 33 lbs per monitor)	104 (Black), 124 (Silver)		\$524
INCLUDES	VERTICAL RANGE	HORIZONTAL RANGE	REQUIRED TO SPECIFY
Dual tier pole arm w/28" pole and 75/100mm VESA adapters.	N/A	16.6"	Model, Finish (ie. 9130-D-28-124)

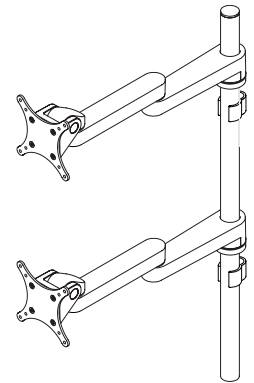

9130-D-28-FM

The 9130-D-28-FM long reach monitor mount features a foldable arm that adjusts vertically up and down along the 28" pole mount.

MODEL	FINISHES		LIST PRICE
9130-D-28-FM (Supports up to 33 lbs per monitor)	104 (Black), 124 (Silver)		\$621
INCLUDES	VERTICAL RANGE	HORIZONTAL RANGE	REQUIRED TO SPECIFY
Dual tier pole arm w/28" pole, 75/100mm VESA adapters and FLEXmount™.	N/A	16.6"	Model, Finish (ie. 9130-D-28-FM-124)

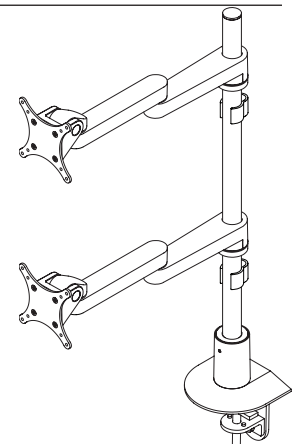

9120-S-14

The 9120-S-14 dual monitor mount displays two flat panel monitors side-by-side on independent articulating monitor arms.

MODEL	FINISHES	LIST PRICE
9120-S-14 (Supports up to 40 lbs per monitor)	104 (Black), 124 (Silver)	\$524

INCLUDES	VERTICAL RANGE	HORIZONTAL RANGE	REQUIRED TO SPECIFY
Single tier pole arm w/14" pole and 75/100mm VESA adapters.	N/A	24.6" (on center) max span in config. as shown	Model, Finish (ie. 9120-S-14-124)

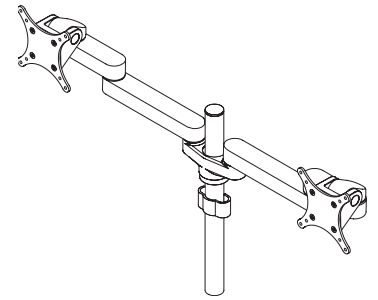

9120-S-14-FM

Easily mount two monitors side by side with the space-saving dual monitor mount.

MODEL	FINISHES	LIST PRICE
9120-S-14-FM (Supports up to 40 lbs per monitor)	104 (Black), 124 (Silver)	\$619

INCLUDES	VERTICAL RANGE	HORIZONTAL RANGE	REQUIRED TO SPECIFY
Single tier pole arm w/14" pole, 75/100mm VESA adapters and FLEXmount™.	N/A	24.6" (on center) max span in config. as shown	Model, Finish (ie. 9120-S-14-FM-124)

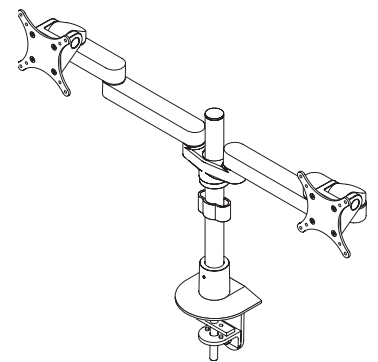

9120-D-28

Save space and boost productivity with the 9120-D-28 quad monitor setup.

MODEL	FINISHES	LIST PRICE
9120-D-28 (Supports up to 40 lbs per monitor)	104 (Black), 124 (Silver)	\$929

INCLUDES	VERTICAL RANGE	HORIZONTAL RANGE	REQUIRED TO SPECIFY
Dual tier pole arm w/28" pole and 75/100mm VESA adapters.	N/A	24.6" (on center) max span in config. as shown	Model, Finish (ie. 9120-D-28-124)

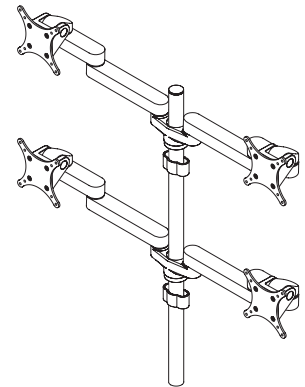

9120-D-28-FM

Mount four flat panel monitors side by side and position each monitor independently, allowing for easy adjustment and placement.

MODEL	FINISHES	LIST PRICE
9120-D-28-FM (Supports up to 40 lbs per monitor)	104 (Black), 124 (Silver)	\$1,028

INCLUDES	VERTICAL RANGE	HORIZONTAL RANGE	REQUIRED TO SPECIFY
Dual tier pole arm w/28" pole, 75/100mm VESA adapters and FLEXmount™.	N/A	24.6" (on center) max span in config. as shown	Model, Finish (ie. 9120-D-28-FM-24)

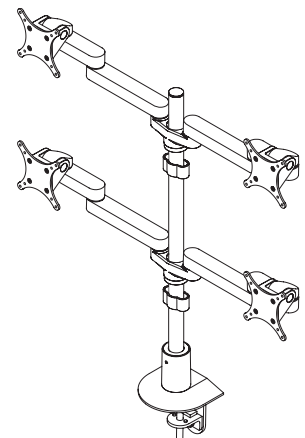

9163-S-14

Ideal for a dual large flat panel monitor setup, the 9163 places 20"+ monitors side by side in a space saving pole mount.

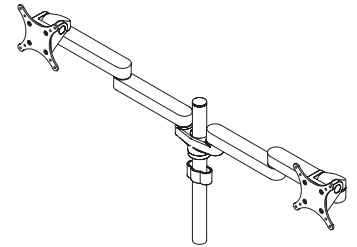

MODEL	FINISHES		LIST PRICE
9163-S-14 (Supports up to 40 lbs per monitor)	104 (Black), 124 (Silver)		\$549
INCLUDES	VERTICAL RANGE	HORIZONTAL RANGE	REQUIRED TO SPECIFY
Single tier pole arm w/14" pole and 75/100mm VESA adapters.	N/A	31.6" (on center) max span in config. as shown	Model, Finish (ie. 9163-S-14-124)

9163-S-14-FM

The extra-long dual articulating arms make this mount ideal for large monitors (20 inches or more).

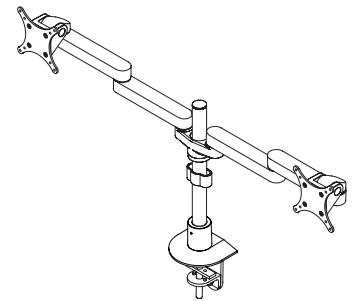

MODEL	FINISHES		LIST PRICE
9163-S-14-FM (Supports up to 40 lbs per monitor)	104 (Black), 124 (Silver)		\$646
INCLUDES	VERTICAL RANGE	HORIZONTAL RANGE	REQUIRED TO SPECIFY
Single tier pole arm w/14" pole, 75/100mm VESA adapters and FLEXmount™.	N/A	31.6" (on center) max span in config. as shown	Model, Finish (ie. 9163-S-14-FM-124)

9163-D-28

Mount four flat panels in minimal space with this feature-packed quad monitor stand.

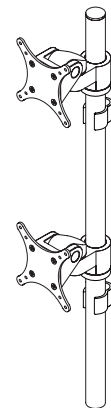

MODEL	FINISHES		LIST PRICE
9163-D-28 (Supports up to 40 lbs per monitor)	104 (Black), 124 (Silver)		\$942
INCLUDES	VERTICAL RANGE	HORIZONTAL RANGE	REQUIRED TO SPECIFY
Dual tier pole arm w/28" pole and 75/100mm VESA adapters.	N/A	31.6" (on center) max span in config. as shown	Model, Finish (ie. 9163-D-28-124)

9163-D-28-FM

Quad flat panel mount features a space-saving design.

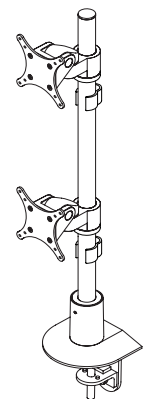

MODEL	FINISHES		LIST PRICE
9163-D-28-FM (Supports up to 40 lbs per monitor)	104 (Black), 124 (Silver)		\$1,049
INCLUDES	VERTICAL RANGE	HORIZONTAL RANGE	REQUIRED TO SPECIFY
Dual tier pole arm w/28" pole, 75/100mm VESA adapters and FLEXmount™.	N/A	31.6" (on center) max span in config. as shown	Model, Finish (ie. 9163-D-28-FM-124)

8326

The 8326 vertical mounting track provides a space-efficient method of elevating your entire computer system.

MODEL	FINISHES	LIST PRICE
8326-13 (13" vertical wall track)	104 (Black), 124 (Silver), 248 (White)	\$154
8326-19 (19" vertical wall track)	104 (Black), 124 (Silver), 248 (White)	\$203
8326-31 (31" vertical wall track)	104 (Black), 124 (Silver), 248 (White)	\$245

INCLUDES	VERTICAL RANGE	HORIZONTAL RANGE	REQUIRED TO SPECIFY
Vertical wall track and cable cap.	N/A	N/A	Model, Finish (ie. 8326-19-104)

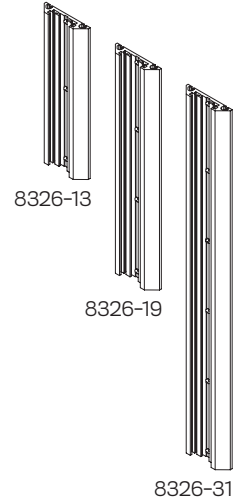

8328

Track mount allows arms to be added to the 8326 wall track. Compatible with most HAT Design Works articulating arms.

MODEL	FINISHES	LIST PRICE
8328	104 (Black), 124 (Silver), 248 (White)	\$125

INCLUDES	VERTICAL RANGE	HORIZONTAL RANGE	REQUIRED TO SPECIFY
Wall track mount.	N/A	7.6" (from wall)	Model, Finish (ie. 8328-104)

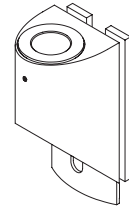

7509-NM

The 7509 data entry monitor arm features a keyboard tray that can be folded flat when not in use and a slide-out mouse tray that accommodates left- or right-hand users. Compatible with 75/100mm VESA monitors.

MODEL	FINISHES	LIST PRICE
7509-1000HY-NM (Supports monitors 6-23 lbs)	104 (Black), 124 (Silver), 248 (White)	\$1,167
7509-1000HY (includes FlexMount)	104 (Black), 124 (Silver), 248 (White)	\$1,299

INCLUDES	VERTICAL RANGE	HORIZONTAL RANGE	REQUIRED TO SPECIFY
7500 series articulating arm with 8209 flip-up keyboard tray. * NM version requires 8328 track mount.	18"	27"	Model, Finish (ie. 7509-1000HY-104)

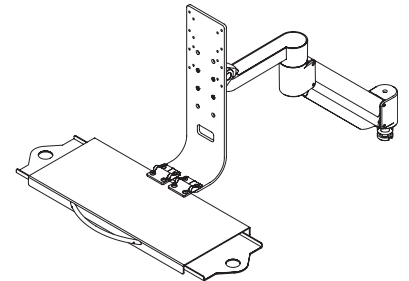

7019-500HY-NM

Data-entry arm comprised of a 7000 arm with large keyboard tray. Accommodates keyboard and mouse.

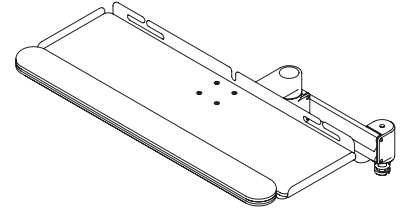

MODEL	FINISHES	LIST PRICE
7019-500HY-NM (Supports monitors 6-23 lbs)	104 (Black), 124 (Silver), 248 (White)	\$703

INCLUDES	VERTICAL RANGE	HORIZONTAL RANGE	REQUIRED TO SPECIFY
7000 series articulating arm with large keyboard tray. * Requires 8328 track mount.	16"	24"	Model, Finish (ie. 7019-500HY-NM-104)

8335 CPU Holders

Sturdy metal construction keeps CPU safe. Mounts to 8326 vertical wall track.

MODEL	FINISHES	LIST PRICE
8335-SM (Adjusts to 2"-3" wide)	104 (Black), 124 (Silver), 248 (White)	\$253
8335-MD (Adjusts to 3"-5" wide)	104 (Black), 124 (Silver), 248 (White)	\$277
8335-LG (Adjusts to 5"-7.5" wide)	104 (Black), 124 (Silver), 248 (White)	\$298

INCLUDES	VERTICAL RANGE	HORIZONTAL RANGE	REQUIRED TO SPECIFY
CPU mount.	N/A	N/A	Model, Finish (ie. 8335-SM-104)

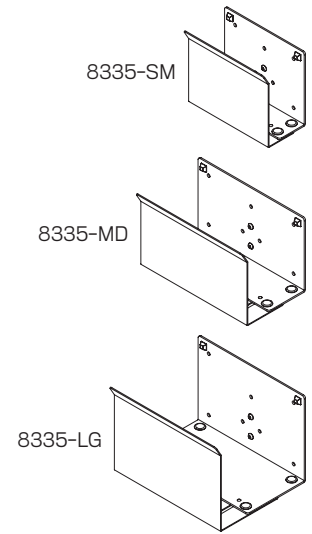

9110

This flexible mount offers pivot and tilt of the monitor or TV.

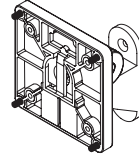

MODEL	FINISHES		LIST PRICE
9110 (Support monitors up to 45 lbs)	104 (Black), 124 (Silver)		\$89
INCLUDES	VERTICAL RANGE	HORIZONTAL RANGE	REQUIRED TO SPECIFY
LCD wall mount and 75/100mm VESA adapter.	N/A	4" (from wall)	Model, Finish (ie. 9110-104)

9110-4

Mount LCD monitor or flat panel TV to wall with the 9110-4 wall mount. Includes a 4" extension arm.

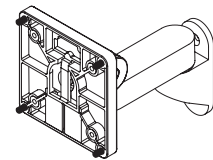

MODEL	FINISHES		LIST PRICE
9110-4 (Support monitors up to 40 lbs)	104 (Black), 124 (Silver)		\$150
INCLUDES	VERTICAL RANGE	HORIZONTAL RANGE	REQUIRED TO SPECIFY
LCD wall mount with 4" extension arm and 75/100mm VESA adapter.	N/A	7.6" (from wall)	Model, Finish (ie. 9110-4-104)

9110-4-4

Pivot, tilt, and rotate a monitor or flat screen TV with the 9110-4-4 wall mount.

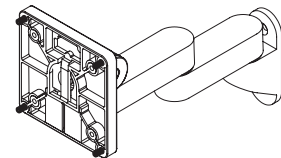

MODEL	FINISHES		LIST PRICE
9110-4-4 (Support monitors up to 40 lbs)	104 (Black), 124 (Silver)		\$217
INCLUDES	VERTICAL RANGE	HORIZONTAL RANGE	REQUIRED TO SPECIFY
LCD wall mount with (2) 4" extension arms and 75/100mm VESA adapter.	N/A	11" (from wall)	Model, Finish (ie. 9110-4-4-104)

9110-8.5

Provides pivot, tilt and rotation. 8.5" extension arm included.

MODEL	FINISHES	LIST PRICE
9110-8.5 (Support monitors up to 40 lbs)	104 (Black), 124 (Silver)	\$184

INCLUDES	VERTICAL RANGE	HORIZONTAL RANGE	REQUIRED TO SPECIFY
LCD wall mount with 8.5" extension arm and 75/100mm VESA adapter.	N/A	11.1" (from wall)	Model, Finish (ie. 9110-8.5-104)

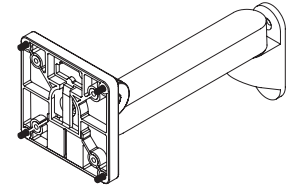

9110-8.5-4

Pivot, tilt, and rotate a monitor or flat screen TV with the 9110-8.5-4 wall mount. Provides 12.5" of extension and can fold back against wall.

MODEL	FINISHES	LIST PRICE
9110-8.5-4 (Support monitors up to 35 lbs)	104 (Black), 124 (Silver)	\$250

INCLUDES	VERTICAL RANGE	HORIZONTAL RANGE	REQUIRED TO SPECIFY
LCD wall mount with an 8.5" and 4" extension arms and 75/100mm VESA adapter.	N/A	14.6" (from wall)	Model, Finish (ie. 9110-8.5-4-104)

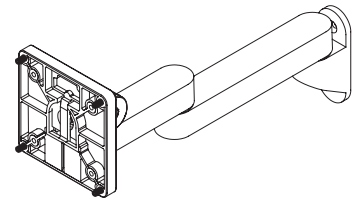

9110-8.5-8.5

Provides pivot, tilt and rotation. (2) 8.5" extension arms included.

MODEL	FINISHES	LIST PRICE
9110-8.5-8.5 (Support monitors up to 28 lbs)	104 (Black), 124 (Silver)	\$284

INCLUDES	VERTICAL RANGE	HORIZONTAL RANGE	REQUIRED TO SPECIFY
LCD wall mount with (2) 8.5" extension arms and 75/100mm VESA adapter.	N/A	18.1" (from wall)	Model, Finish (ie. 9110-8.5-8.5-104)

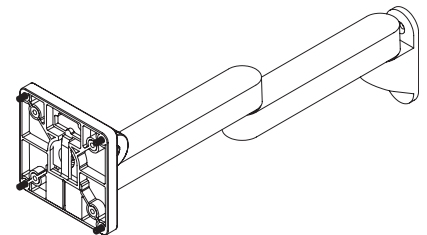

8538

VESA Slider Bracket with quick release

MODEL	FINISHES		LIST PRICE
8538	104 (Black), 124 (Silver), 248 (White)		\$65
INCLUDES	VERTICAL RANGE	HORIZONTAL RANGE	REQUIRED TO SPECIFY
75/100MM VESA adapter.	N/A	N/A	Model, Finish (ie. 8538-124)

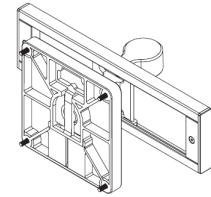

Next Gen Tilter

Quick-install/quick-release mechanism instantly and securely snaps monitor into position for quick and simple set-up.

MODEL	FINISHES		LIST PRICE
8500	104 (Black), 124 (Silver), 248 (White)		\$61
INCLUDES	VERTICAL RANGE	HORIZONTAL RANGE	REQUIRED TO SPECIFY
Quick-release VESA adapter.	N/A	N/A	Model, Finish (ie. 8500-124)

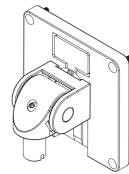

8111

7000 Series FLEXmount™—six mounting solutions in one kit.

MODEL	FINISHES		LIST PRICE
8111	104 (Black), 124 (Silver), 248 (White)		\$93
INCLUDES	VERTICAL RANGE	HORIZONTAL RANGE	REQUIRED TO SPECIFY
7000 Series FLEXmount™.	N/A	N/A	Model, Finish (ie. 8111-124)

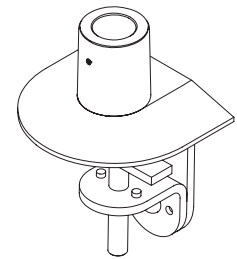

8408

Supports two monitor arms. Mount clamps to desk or through grommet.

MODEL	FINISHES		LIST PRICE
8408	104 (Black), 124 (Silver), 248 (White)		\$166
INCLUDES	VERTICAL RANGE	HORIZONTAL RANGE	REQUIRED TO SPECIFY
Dual arm mount.	N/A	N/A	Model, Finish (ie. 8408-124)

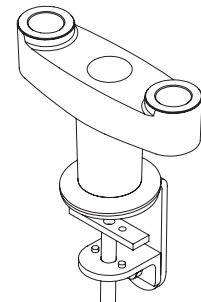

8246

Our slatwall mount features secure attachment as well as fast installation. Cables can be routed between the mount and slatwall. HAT Design Works offers slatwall options for most popular slatwall systems, call for details.

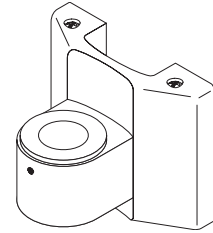

MODEL	FINISHES		LIST PRICE
8246	104 (Black), 124 (Silver), 248 (White)		\$100
INCLUDES	VERTICAL RANGE	HORIZONTAL RANGE	REQUIRED TO SPECIFY
Slatwall mount.	N/A	N/A	Model, Finish (ie. 8246-124)

8171-6 / 8171-75-6

Raise the height of your arm by 6". Increases range of height adjust on arm. Does not impede 360° rotation.



MODEL	FINISHES		LIST PRICE
8171-6 (7000 Series Extender Tube)	104 (Black), 124 (Silver), 248 (White)		\$122
8171-75-6 (7500 Series Extender Tube)	104 (Black), 124 (Silver), 248 (White)		\$215
INCLUDES	VERTICAL RANGE	HORIZONTAL RANGE	REQUIRED TO SPECIFY
6" Extender tube.	N/A	N/A	Model, Finish (ie. 8171-6-124)

9118-9112 / 9118-9130 / 9118-12

Articulating extension arms that can be added to 9110 and pole products.

MODEL	FINISHES		LIST PRICE
9118-9112 (4" extension arm)	104 (Black), 124 (Silver), 248 (White)		\$62
9118-9130 (8.5" extension arm)	104 (Black), 124 (Silver), 248 (White)		\$95
9118-12 (12" extension arm)	104 (Black), 124 (Silver), 248 (White)		\$121
INCLUDES	VERTICAL RANGE	HORIZONTAL RANGE	REQUIRED TO SPECIFY
Extension arm.	N/A	N/A	Model, Finish (ie. 9118-9112-124)

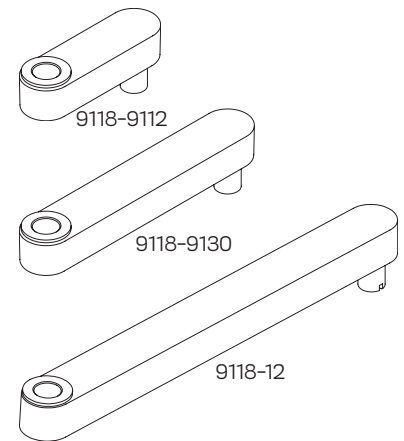

8428 (Switch™)

Switch is a highly configurable multi-monitor bracket. Switch meets your current mounting requirements, but also easily adapts for future needs. You can convert your monitor configurations with little time or effort. Accommodates most monitors up to 24" widescreen (up to 15 lbs per monitor).

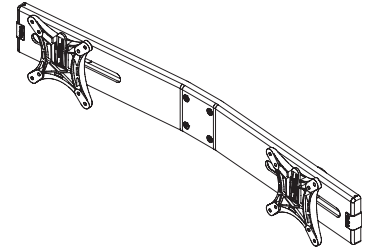

MODEL	FINISHES	LIST PRICE
8428	N/A (Silver)	\$171

INCLUDES	VERTICAL RANGE	HORIZONTAL RANGE	REQUIRED TO SPECIFY
Dual monitor arm bracket with (2), 75/100mm VESA adapters.	N/A	N/A	Model (ie. 8428)

Winston E-Desk Beam

Winston E-Desk Beam raises and secures monitors to desk.

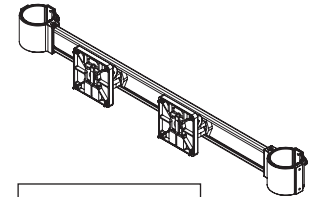

MODEL	FINISHES	LIST PRICE
WNSTE-DESK-BEAM	Black, White	\$191

INCLUDES	VERTICAL RANGE	HORIZONTAL RANGE	REQUIRED TO SPECIFY
Dual monitor arm bracket with (2), 75/100mm VESA adapters.	N/A	N/A	Model (ie.WNSTE-DESK-BEAM-BLK)

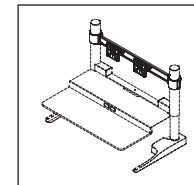

Snap On Charging Caps

Powered USB ports are built directly into this snap on charging cap that is compatible with the top down mount.

MODEL	COMPATIBILITY	FINISHES	LIST PRICE
CHG-CAP-1	Single top down	BK (Black), SI (Silver), WH (White)	\$245
CHG-CAP-2	Dual top down	BK (Black), SI (Silver), WH (White)	\$245
CHG-CAP-E	Dual E2	BK (Black), SI (Silver), WH (White)	\$245

INCLUDES	VERTICAL RANGE	HORIZONTAL RANGE	REQUIRED TO SPECIFY
Features 2 USB-A and 1 USB-C port	N/A	N/A	Model, Finish (ie. CHG-CAP-1-SI)

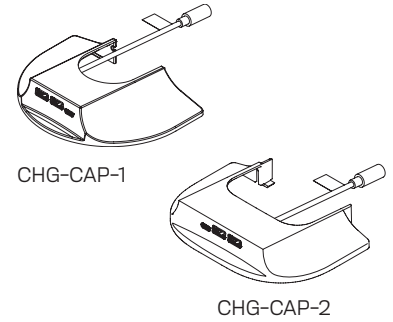

Reya USB Hub

MODEL	FINISHES	LIST PRICE
PWR-AC	BK (Black), WH (White)	\$145

INCLUDES	VERTICAL RANGE	HORIZONTAL RANGE	REQUIRED TO SPECIFY
Includes one USB-A port and a one USB-C port	N/A	N/A	Model, Finish (ie. PWR-AC-BK)

*** Compatible with Mid and Hi HAT bases only**

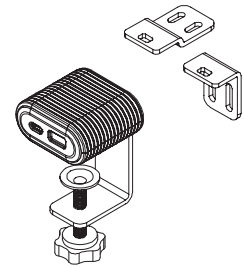

Reya Standard Surface Power Module

MODEL	FINISHES	LIST PRICE
PWR-ACC	BK (Black), WH (White)	\$325

INCLUDES	VERTICAL RANGE	HORIZONTAL RANGE	REQUIRED TO SPECIFY
Features 2 power receptacles, 1 USB-A and 2 USB-C ports	N/A	N/A	Model, Finish (ie. PWR-ACC-BK)



Reya Wireless Surface Power Module

MODEL	FINISHES		LIST PRICE
PWR-ACC-WRLS	BK (Black), WH (White)		\$475
INCLUDES	VERTICAL RANGE	HORIZONTAL RANGE	REQUIRED TO SPECIFY
Features 2 power receptacles, 1 USB-A and 2 USB-C ports, fast Qi certified wireless charging	N/A	N/A	Model, Finish (ie. PWR-ACC-WRLS-BK)

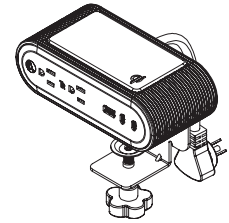

Reya Power Strip

MODEL	FINISHES		LIST PRICE
PWR-STRP	BK (Black), WH (White)		\$130
INCLUDES	VERTICAL RANGE	HORIZONTAL RANGE	REQUIRED TO SPECIFY
6 power receptacles	N/A	N/A	Model, Finish (ie. PWR-STRP)

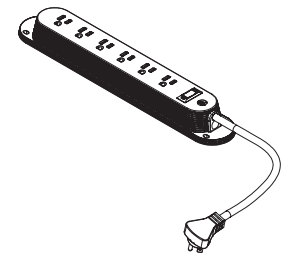

Reya Power Strip With Hardwired Standard Surface Power Module

MODEL	FINISHES		LIST PRICE
PWR-ACC-STRP	BK (Black), WH (White)		\$500
INCLUDES	VERTICAL RANGE	HORIZONTAL RANGE	REQUIRED TO SPECIFY
Surface module: features 2 power receptacles, 1 USB-A and 2 USB-C ports Power strip: 6 power receptacles	N/A	N/A	Model, Finish (ie. PWR-ACC-STRP)

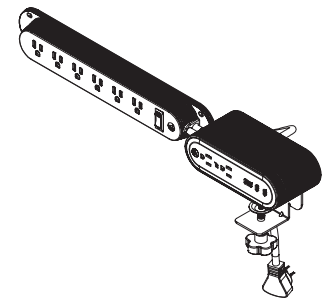

KT-27

Extended reach keyboard arm w/19" keyboard tray with swivel mouse tray.

MODEL	FINISHES	LIST PRICE
KT-27	N/A (Black)	\$350

INCLUDES	ADJUSTMENT	REQUIRED TO SPECIFY
Keyboard arm, tray and 11" track	Tilt adjustment, +10/-10 degrees	Model (ie. KT-27)

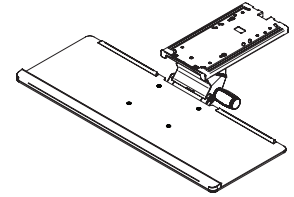

Pocket Cable Management

Have everything fit neatly into your Pocket. Our mesh cable management sleeve is a clean, simple, and efficient solution to your cord management problem.

MODEL	FINISHES	LIST PRICE
CMT (Standard - 38" W x 5" D)	04 (Black), 06 (Grey)	\$205
CMT-24 (Mini - 24" W x 5" D)	04 (Black), 06 (Grey)	\$155

INCLUDES	REQUIRED TO SPECIFY
Mounting hardware	Model (ie. CMT-04)

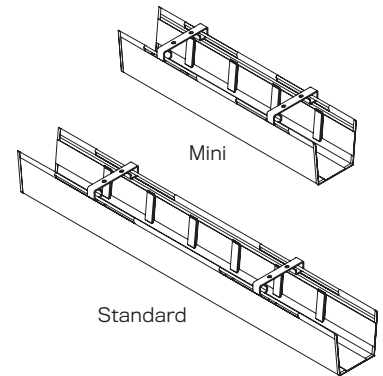

Mobile Pedestal Slim

MODEL	FINISHES	LIST PRICE
MPEDBF-10 (Pedestal)	BK (Black), SI (Silver), WH (White)	\$623
MPEDCUS-10 (Cushion, In-Stock Color)	15-13 (Charcoal)	\$132
MPEDCUS-10 (Cushion, Standard Colors)	Visit hatdw.com for color options	\$138

INCLUDES	REQUIRED TO SPECIFY
Includes lock, key, and pencil tray	Model (ie. MPEDBF-10-BK)

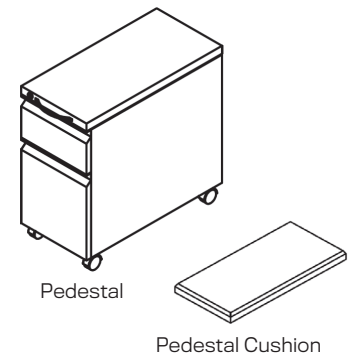

Mobile Pedestal

MODEL	FINISHES	LIST PRICE
MPEDBF-15 (Pedestal)	BK (Black), SI (Silver), WH (White)	\$623
MPEDCUS-15 (Cushion, In-Stock Color)	15-13 (Charcoal)	\$132
MPEDCUS-15 (Cushion, Standard Colors)	Visit hatdw.com for color options	\$138

INCLUDES	REQUIRED TO SPECIFY
Includes lock, key, and pencil tray	Model (ie. MPEDBF-15-BK)

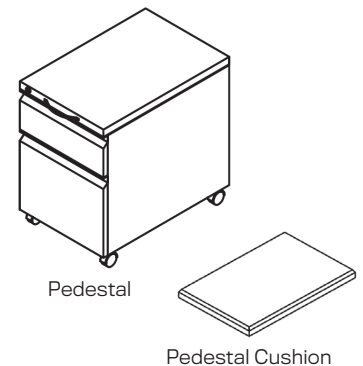



HAT
DESIGN WORKS™
HUMAN ACTIVE TECHNOLOGY

HAT Design Works
100 Kuebler Road
Easton, PA 18040

800 524 2744
hatdw.com